



## Series 72 - Rotary Plug Valve Type 72.4

Double eccentric control valve for process engineering and industrial applications

<b>Valve size</b>	DN 25 to 300	NPS 1 to 12
<b>Nominal pressure</b>	PN 10 to 40	Class 150 and 300
<b>Temperature</b>	-100 to +500 °C	-148 to +932 °F



### Valve body made of

- Cast/carbon steel or
- Stainless cast/carbon steel

### Seat version

- Metal sealing, armored or unarmored
- Soft sealing

The valves can be equipped with different accessories, such as positioners, solenoid valves and other accessories according to VDI/VDE 3845.

### Standard version

For temperatures from -100 to 400 °C -148 to 752 °F

### Version

Sandwich-style body no flanges

- DN 25 to DN 300, PN 10/PN 16/PN 25/PN 40, face-to-face dimensions acc. to EN 558, Table 2, Series 36
- NPS 1 to NPS 12, Class 150/Class 300, face-to-face dimensions acc. to EN 558, Table 2, Series 36

### Further versions

- TA-Luft packing/double packing
- With high and low temperature extension IT1,
- Double stuffing box DSB
- Cleaning connections
- Protective sleeve
- Special materials for body and trim
- Noise-reducing features
- Flange version with tongue/groove according to EN 1092-1
- RF according to ANSI
- Versions for higher and lower temperatures on request

### Configuration samples



Fig. 1: Type 72.4/AT



Fig. 2: Type 72.4/R

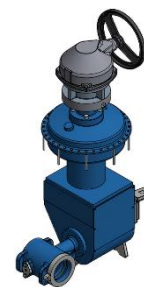

Fig. 3: Type 72.4/MZ



Fig. 4: Type 72.4/MD

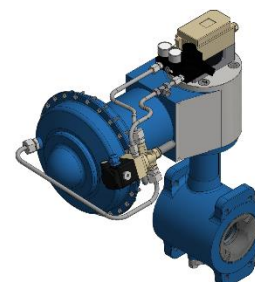

Fig. 5: Type 72.4/MN

### Special designs



Fig. 6: 72.4-IT1



Fig. 7: 72.4-DSB



Fig. 8: 72.4-Cleaning connections



Fig. 9: 72.4-Protective sleeve

## Principle of operation

The shaft/plug arrangement is eccentric Figs. 3 and 4. The double-eccentric design of the rotary plug valve is achieved in combination with the offset of the plug's pivot. When turning the plug shaft from closed position in opening direction, the double-eccentric design allows the plug to lift off the seat smoothly without initial breakaway torque. The valve is not opened suddenly and shows a stable control response even with small opening angles. The rotary plug valve can be used for both directions of flow.

For gases and vapors, the direction of flow is FTC medium closes.

The flow coefficient depends on the opening angle of the valve.

Using positioners or cam disks, the natural characteristic of the rotary plug valve can be modified to achieve a linear or equal-percentage characteristic Figs. 5 and 6.

## Fail-safe action

In combination with the Type R/M/AT/S Rotary Actuators, the control valve has two fail-safe actions, which become effective when the piston is relieved of pressure or when the supply air fails.

**Valve CLOSED without supply air:** rotary plug valve is closed when the supply air fails.

**Valve OPEN without supply air:** rotary plug valve is opened when the supply air fails.

## Installation

Observe the direction of flow indicated by the arrow on the valve body.

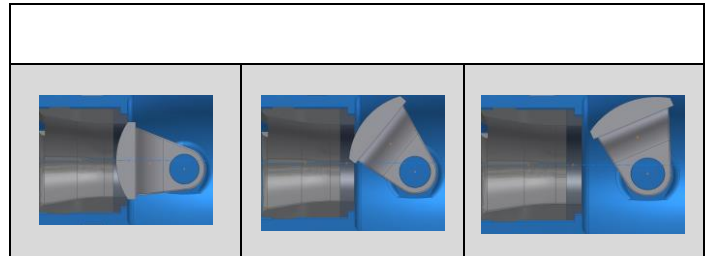

Fig. 10: Plug movement with double-eccentric arrangement

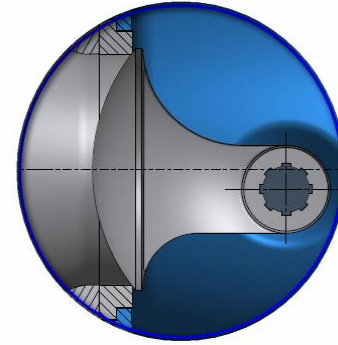

Fig. 11: Double-Eccentric Principle

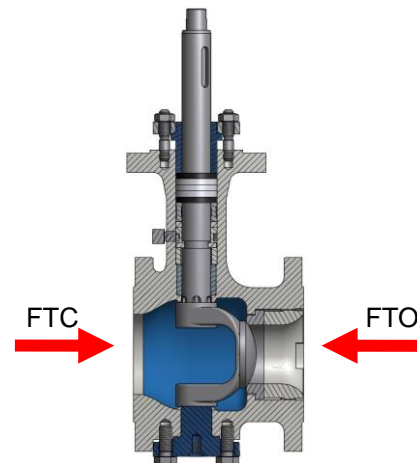

Fig. 12: Flow Direction

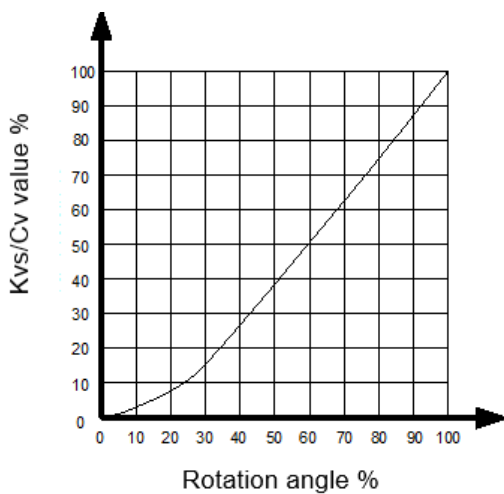

Fig. 13: Natural characteristic

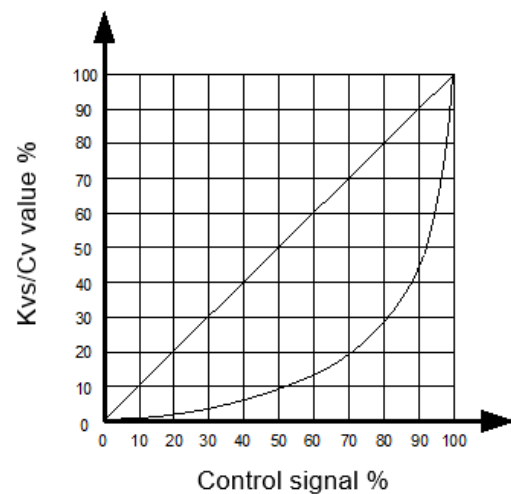
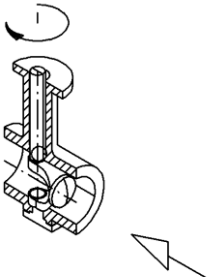
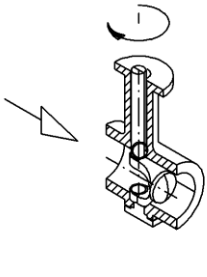

Fig. 14: Equal-percentage and linear characteristic

**Table 1: Technical data**

Type	72.4	
Valve size	DN 25 to DN 300	NPS 1 to NPS 12
Style	Flange	Flange
Flange pressure rating	PN 10/16/25/40	ANSI Class 150/Class 300
Max. operating pressure	40 bar	50 bar
Overall length	EN 558, Table 2, Series 36	EN 558, Table 2, Series 36
Flange bore/form	DIN EN 1591-1/DIN 2500	ASME B16.5
Seat ring	 <p>Direction of flow from the front: FTO</p>	 <p>Direction of flow from behind: FTC</p>
Characteristic	Equal percentage or linear using cam disk or positioner characteristic On/off valve	
Rangeability	200:1	
Temperature range	Medium: -100 to +500 °C	
Opening angle	75°	

**Table 2: Materials**

Body	1.0619/A216 WCC	1.4408/A351 CF8M
Shaft	1.4404	
Plug	1.4404/Stellite 6	
Trunnion bearing	1.4404	
Seat ring	1.4404 armored with carbide metal/seat with soft sealing	
Seat holder	1.4404	
PTFE ring on seat	PTFE	
O-ring on seat	FPM 80 VR1	
Bearing bushing	1.4404/plastic	
Packing	1.4404	
O-ring	FPM 80 VR1	
Screw plug	1.4404	
Screw plug seal	1.4404	
Trunnion bearing seal	Graphite/stainless steel/PTFE	
Packing	PTFE/graphite	

**Table 3. Kvs and Cv Coefficients**

**3a. Seat with metal sealing FTO**

<b>DN</b>		<b>25</b>	<b>40</b>	<b>50</b>	<b>80</b>	<b>100</b>	<b>150</b>	<b>200</b>	<b>250</b>	<b>300</b>
<b>NPS</b>		<b>1</b>	<b>1 1/2</b>	<b>2</b>	<b>3</b>	<b>4</b>	<b>6</b>	<b>8</b>	<b>10</b>	<b>12</b>
<b>Flow rate</b>										
<b>100%</b>	<b>Kvs</b>	16	36	70	220	360	720	1100	1950	2700
	<b>Cv</b>	18	42	81	254	416	832	1272	2254	3121
	<b>Seat Ø mm</b>	18	26	36	60	76	105	135	170	210
<b>60%</b>	<b>Kvs</b>	12	22	43	145	210	430	630	1230	1500
	<b>Cv</b>	14	25	50	168	243	497	728	1422	1734
	<b>Seat Ø mm</b>	16	21,5	29,5	50	60	86	106	146	163
<b>40%</b>	<b>Kvs</b>	10	16	31	105	150	275	390	850	900
	<b>Cv</b>	12	18	36	121	173	318	451	983	1040
	<b>Seat Ø mm</b>	14	18,5	25,5	44	53	73	88	126	133
<b>25%</b>	<b>Kvs</b>	4	12	19	70	100	185	245	500	640
	<b>Cv</b>	4,6	14	22	81	116	214	283	578	740
	<b>Seat Ø mm</b>	10	16	21	37	45	62	73	102	116

**3b. Seat with metal sealing FTC**

<b>DN</b>		<b>25</b>	<b>40</b>	<b>50</b>	<b>80</b>	<b>100</b>	<b>150</b>	<b>200</b>	<b>250</b>	<b>300</b>
<b>NPS</b>		<b>1</b>	<b>1 1/2</b>	<b>2</b>	<b>3</b>	<b>4</b>	<b>6</b>	<b>8</b>	<b>10</b>	<b>12</b>
<b>Flow rate</b>										
<b>100%</b>	<b>Kvs</b>	16	36	70	210	340	660	810	1300	2100
	<b>Cv</b>	18	42	81	243	393	763	936	1503	2428
	<b>Seat Ø mm</b>	18	26	36	60	76	105	135	170	210
<b>60%</b>	<b>Kvs</b>	12	22	43	135	200	320	410	820	900
	<b>Cv</b>	14	25	50	156	231	370	474	948	1040
	<b>Seat Ø mm</b>	16	21,5	29,5	50	60	86	106	146	163
<b>40%</b>	<b>Kvs</b>	10	16	31	95	120	185	250	540	570
	<b>Cv</b>	12	18	36	110	139	214	289	624	659
	<b>Seat Ø mm</b>	14	18,5	25,5	44	53	73	88	126	133
<b>25%</b>	<b>Kvs</b>	4	12	19	56	90	125	160	320	410
	<b>Cv</b>	4,6	14	22	65	104	145	185	370	474
	<b>Seat Ø mm</b>	10	16	21	37	45	62	73	102	116

**3c. Seat with soft sealing      FTC**

<b>DN</b>	<b>25</b>	<b>40</b>	<b>50</b>	<b>80</b>	<b>100</b>	<b>150</b>	<b>200</b>	<b>250</b>	<b>300</b>
<b>NPS</b>	<b>1</b>	<b>1 1/2</b>	<b>2</b>	<b>3</b>	<b>4</b>	<b>6</b>	<b>8</b>	<b>10</b>	<b>12</b>

**Flow rate**

<b>100%</b>	<b>Kvs</b>	12	40	68	180	290	535	730	1220	2000
	<b>Cv</b>	14	42	79	208	335	618	844	1410	2312
	<b>Seat Ø mm</b>	16	26	35	54	70	98	128	160	204
<b>60%</b>	<b>Kvs</b>	11	22	43	135	200	320	410	820	900
	<b>Cv</b>	13	25	50	156	231	370	474	948	1040
	<b>Seat Ø mm</b>	15	21,5	29,5	50	60	86	106	146	163
<b>40%</b>	<b>Kvs</b>	10	16	31	105	120	185	250	540	570
	<b>Cv</b>	12	18	36	121	139	214	289	624	659
	<b>Seat Ø mm</b>	14	18,5	25,5	46	53	73	88	126	133
<b>25%</b>	<b>Kvs</b>	4	12	19	56	90	125	160	320	410
	<b>Cv</b>	4,6	14	22	65	104	145	185	370	474
	<b>Seat Ø mm</b>	10	16	21	37	45	62	73	102	116

**Table 4:      Weight in kg without actuator**

<b>DN</b>	<b>25</b>	<b>40</b>	<b>50</b>	<b>80</b>	<b>100</b>	<b>150</b>	<b>200</b>	<b>250</b>	<b>300</b>
<b>NPS</b>	<b>1</b>	<b>1½</b>	<b>2</b>	<b>3</b>	<b>4</b>	<b>6</b>	<b>8</b>	<b>10</b>	<b>12</b>
<b>Weight kg</b>	6	10	12	22	33	65	90	136	168

**Table 5:      DIN face-to-face dimensions**

	<b>DN</b>	<b>25</b>	<b>40</b>	<b>50</b>	<b>80</b>	<b>100</b>	<b>150</b>	<b>200</b>	<b>250</b>	<b>300</b>
<b>PN 10</b>	<b>Length mm</b>	<b>102</b>	<b>114</b>	<b>124</b>	<b>165</b>	<b>194</b>	<b>229</b>	<b>243</b>	<b>297</b>	<b>338</b>
<b>PN 16</b>										
<b>PN 25</b>										
<b>PN 40</b>										

**Table 6:      ANSI face-to-face dimensions**

	<b>NPS</b>	<b>1</b>	<b>1½</b>	<b>2</b>	<b>3</b>	<b>4</b>	<b>6</b>	<b>8</b>	<b>10</b>	<b>12</b>
<b>Class 150</b>	<b>Length mm</b>	<b>102</b>	<b>114</b>	<b>124</b>	<b>165</b>	<b>194</b>	<b>229</b>	<b>243</b>	<b>297</b>	<b>338</b>
<b>Class 300</b>										

**Order specifications:**

Type	According to table
Valve size	DN ...
Nominal pressure	PN ...
Body material	According to table
Seat version	Metal or soft sealing
Characteristic	Equal percentage or linear
Kvs/Cv	According to table
Direction of flow	Standard: FTO medium opens Reverse: FTC medium closes
Actuator	Type
Type of mounting	Mounting location of actuator
Fail-safe action	when supply air fails Fail-close Fail-open
Max. differential pressure for	... bar
Supply air	... bar
Bench range	... bar
Accessories	e.g. positioners, limit switches, solenoid valve etc.
Others	e.g. special version, certificates, approvals etc.

VETEC Ventiltechnik GmbH Siemensstraße 12 · 67346 Speyer  
Telefon: 06232 6412-0 · Fax: 06232 42479 · E-mail: [vetec@vetec.de](mailto:vetec@vetec.de) · Internet:  
[www.vetec.de](http://www.vetec.de)  
Sitz der Gesellschaft: 67346 Speyer · Registergericht: Amtsgericht Ludwigshafen  
HRB 51677 · USt-IdNr.: DE149689913 · Geschäftsführer: Uwe Vogel