



Application

Air receiver tank/emergency instrument air supply to compensate for fluctuations in supply pressure to pneumatic control equipment.

The operational reliability of pneumatic control equipment mainly depends on the instrument air supply. The availability of such equipment can be significantly increased through the use of air receiver tanks. The tanks can be used while the plant is running normally. They also act as a buffer in case of emergency.

The stored air volume in the tank can compensate for fluctuations in pressure of the compressed air supply to ensure that pneumatic control equipment can continue to operate without any disruptions. Furthermore, they help improve the positioning accuracy of pneumatic control valves and, ultimately, the quality of the end product.

Upon air supply failure, the tanks can continue to supply air for a controlled plant shutdown in case of emergency

The tanks can be sized and configured to meet various requirements. They are suitable for supplying linear or rotary valves with single or double-acting actuators. One or more valves can be connected to a tank.

Versions

- Compressed air tanks ranging from 10 to 20 liters for direct mounting on the valve or horizontal or vertical compressed air tanks ranging from 20 to 750 liters
- Maximum 11 bar operating pressure
- Tanks made of steel with painted or primed exterior and corrosion-protected interior (stainless steel also available)
- Rated capacity, preferably lying with feet (also available in upright position) Small sized tanks for mounting directly to the control valve or suitable for wall mounting (see Fig. 1)
- Connections with threaded fittings or flanges
- Pressure vessel approval according to 2014/68/EU (European Pressure Equipment Directive) or ASME approval
- Supply air inlet fitted with check valve or pneumatic lock-up valve A shut-off valve can also be fitted on request.
- Optionally with pressure gauge, pressure switch for monitoring the pressure or safety valve for emergency pressure relief
- Other versions on request



Fig. 1: Air receiver tank/emergency air supply up to 750 liter capacity, horizontal tank

Principle of operation (see Fig. 3 and Fig. 2)

A check valve is normally fitted at the supply air inlet of the air receiver tank (see Fig. 2).

Upon air supply failure, the check valve prevents the air stored in the tank from flowing back through the tank inlet. This ensures that the reserve air trapped in the tank can be used to continue operation of the connected control valves independent of the air supply.

The tank volume determines how long the emergency supply to the continuously operating pneumatic equipment (e.g. positioners) lasts between the air supply failure and safe plant shutdown. The air required to intermittently supply the pneumatic actuators is also included in the calculation to size the tank.

Fig. 3 shows a sample application in which a SAMSON control valve must be able to perform 3 full valve strokes within 15 minutes after failure of the compressed air supply. During this period, the air supply to the positioner must be maintained and the actuator must be filled with air three times to stroke the valve.

The air pressure in the tank steadily decreases as the positioner uses up air. In contrast, a sudden drop in pressure occurs every time the valve is stroked and air flows out of the tank to fill the actuator. It is quickly evident that the tank pressure must always be higher than the required actuator pressure during the emergency supply operation.

We recommend selecting the supply pressure at least 1 bar higher than the required actuator pressure. This ensures that the tank is not oversized and allows the check valve fitted at the inlet to overcome the pressure drop.

A detailed RFQ form to enter all the data required to size the tank as well as configure any additional tank options can be found on pages 4 and 5.

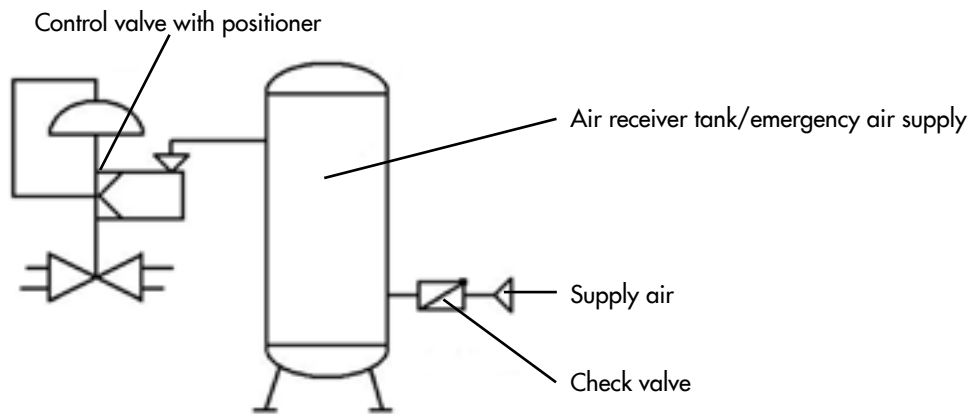

Fig. 2: Installation example: pneumatic hook-up of the emergency air supply

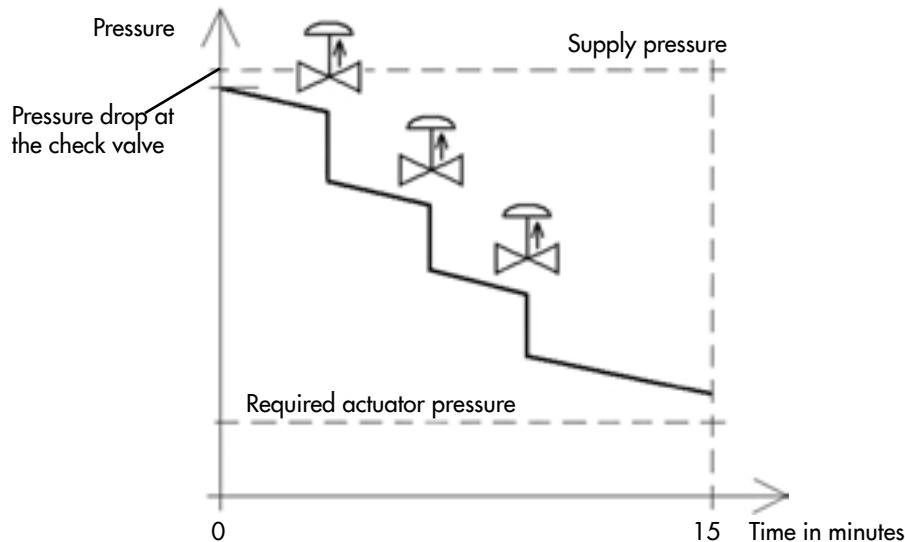
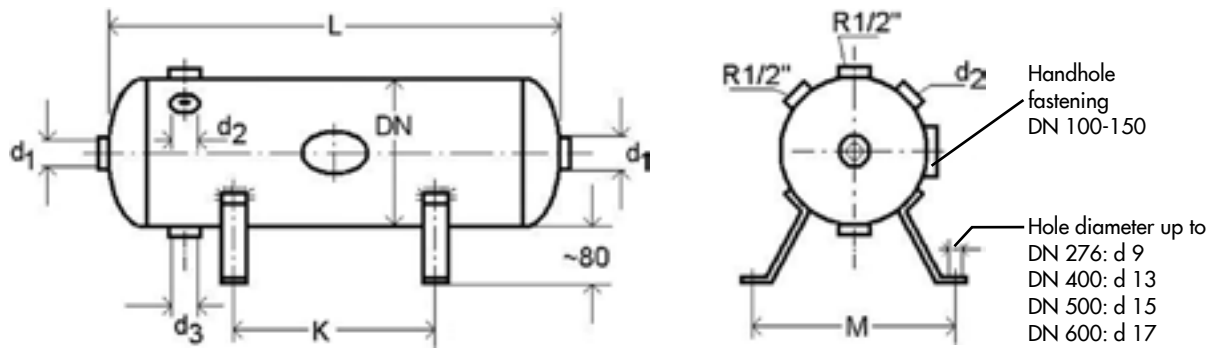

Fig. 3: Tank pressure over time

Dimensional drawings

Dimensions of standard version, approval according to 2014/68/EU



Legend

d_1 Air inlet and outlet

d_3 Water drainage

Unused connections are sealed with a stopper

Fig. 4: Dimensional drawings

Table 1: Technical data · All dimensions in mm · All pressures in bar (gauge)

Permissible operating pressure	Rated tank capacity in liter	Valve size	L	d_1	d_2	d_3	K	M	Number of handholes
10	20	206	660	R 1/2	R 1/4	R 1/2	400	210	-
	40	276	745				450	250	
11	90	360	970	R 1/2	R 1/2		550	300	1
	150	400	1300	R 1		800	350		
	250	500	1385		R 1	R 1	1000	450	
	300		1650	R 1/2	550				
	500	600	1910	R 2	R 1	R 1	550		
	750	800	1600				800	660	



RFQ Form for Type 7510 Air Receiver Tank/Emergency Air Supply (1/2)

Customer data		
Company		
Address		
Name		
Phone number		
E-mail		
Send your inquiry to your regional SAMSON contact or e-mail it to ► systems-de@samsongroup.com		
Supply air		
Medium: Instrument air Nitrogen Other:	Air supply: Min. pressure: bar(g) Max. pressure: bar(g) Temperature: °C	Assignment: Number of valve strokes: Emergency supply period: Other:
Control valve data		
Type ... Valve:	Actuator: SAMSON Type Other: Single acting or Double acting Fail-close or Fail-open Diaphragm area: cm ² (e.g. 120 cm ² , 2 x 2800 cm ² etc.) Operating travel: mm (e.g 15 mm etc.) Signal pressure range: ... bar(g) (e.g. 0.4 to 2.0 bar(g) etc.) Required supply pressure: bar(g) (e.g. 2.4 bar(g) etc.) Other makes: Actuator volume: liter Required supply pressure: bar(g)	
Valve accessories		
Positioner: SAMSON Type Other: (including air consumption specifications)	Solenoid valves: SAMSON Type Other: (including air consumption specifications) Quantity: pc.	Supply pressure regulator: SAMSON Type Other: (including air consumption specifications)



RFQ Form for Type 7510 Air Receiver Tank/Emergency Air Supply (2/2)

Tank	
Material: Steel Stainless steel (1.4541 or 1.4571) Other:	Design: Maximum operating pressure: 11 bar(g) and maximum operating temperature range: -10 to +50 °C Other:
Approval: Pressure vessel with CE marking or approval according to 2014/68/EU (European Pressure Equipment Directive) Other: (e.g. ASME or SQL)	
Surface finishes: Steel tanks only have a primed exterior and a corrosion-protected interior (manufacturer's standard specifications) Stainless steel tanks are pickled by immersion (manufacturer's standard specifications) For other surface finishes, please send the finish specifications to SAMSON.	
Connections: Screw fittings with R thread Flanges Other:	Valve accessories: Made of red brass/bronze Made of steel Made of stainless steel Check valve Pneumatic lock-up valve Safety valve Pressure gauge Pressure switch Ball valve Other:
Notes	

