

SAMSON 3281 & 3286

SAMSON

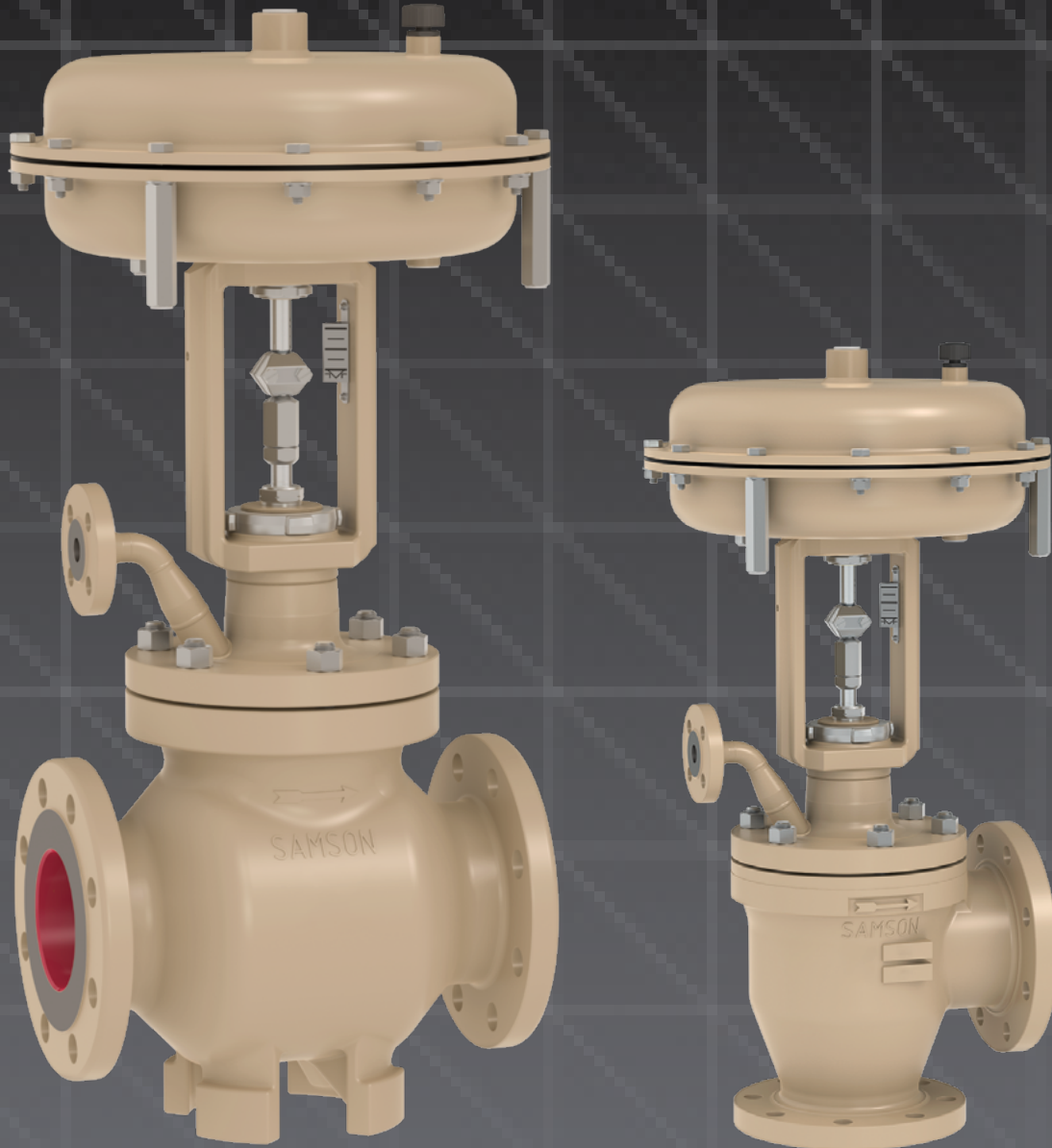

Steam Conditioning Valve

FEATURES AND BENEFITS

Integrated Accessory Attachment

- Eliminates external tubing
- Protects mechanical feedback linkage
- Entire actuator top works can be rotated 360° without disassembly

SAMSON Smart Devices

- Easy push-button positioner initialization
- Intrinsically safe & explosion proof options available
- EXPERTPlus Diagnostics

Low Cooling Water Temperature

- No preheating required above 20 °C (depending on the process conditions)

Flow Divider III

- Low-noise and low-vibration operation
- Excellent heat transfer rates thanks to the large surface area
- Excellent mixing of steam and water
- Fast evaporation of the steam

Long Service Life

- No erosion and temperature shocks as there is no contact between the cooling water and the valve body

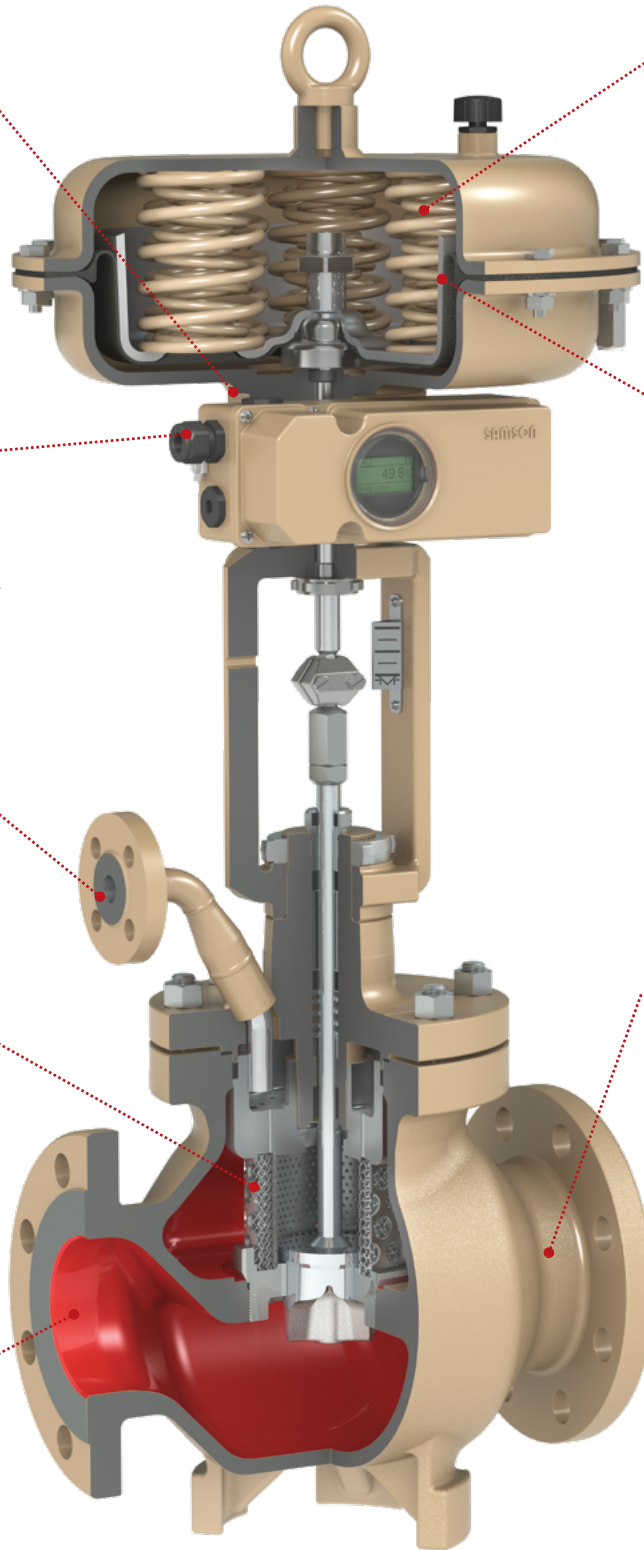

Field Reversible Nested Multi-Spring Actuator

- Reduced height and weight
- Easily convert between fail actions in the field with minimal effort

Rolling Diaphragm

- Greatly reduces diaphragm wear compared to stretching diaphragm design used by competitors.
- Diaphragm design results in very small external air loss

Temperature Control

- Excellent atomization of the water across the entire operating range, the flow velocity at the vena contracta is independent of the flow rate

Short Evaporation Time

- Spray water and steam are mixed where the steam's flow velocity is at its maximum

High Efficiency

- Outlet temperatures as low as 9°F (5°C) above the saturated steam temperature (depending on the process conditions)

Low Cost of Installation

- Compact valve design

DESIGN BENEFITS

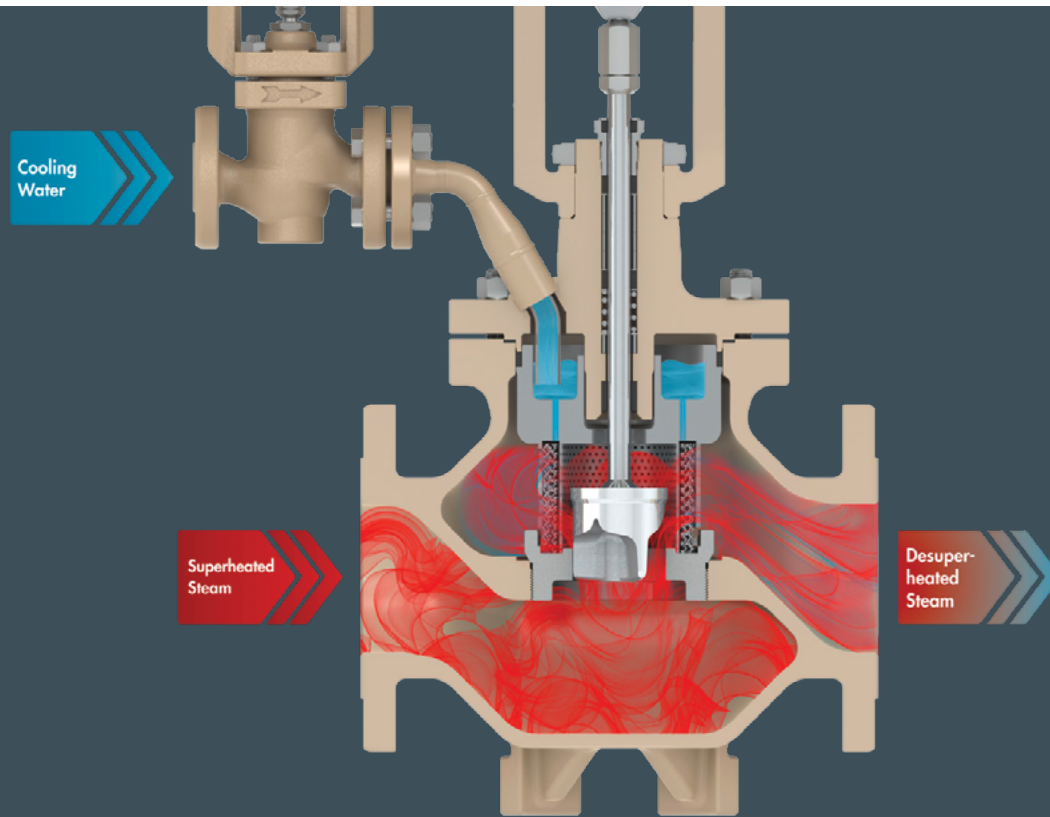

DESUPERHEATING & PRESSURE REDUCTION IN ONE UNIT

Steam-converting valves simultaneously reduce the temperature and pressure of superheated steam.

These control valves inject water into the steam directly downstream of the vena contracta, utilizing the very high velocities created to ensure that the steam and water are mixed optimally.

SAMSON offers valves both in globe style (3281) and Angle style (3286) for steam-converting applications.

STEAM CONVERTING VALVES

- Maximize process efficiency by using steam near saturation temperature
- Minimize the cost of investment as the injected cooling water does not need to be preheated*
- Protect the downstream piping and equipment against excessive pressures and temperatures

*Depending on the process conditions

TYPICAL APPLICATIONS



HEATING OF SUBSTANCES IN THE CHEMICAL INDUSTRY

- Higher efficiency of heat exchangers by using steam near the saturation curve
- Use of high-pressure and low-pressure steam
- Safe and efficient heating of products

STEAM BOX CONTROL IN PULP AND PAPER MILLS

- Supply of constant pressure and temperature to steam boxes Improved mill output thanks to more efficient drying of the paper
- Protection of paper from excessive pressures and temperatures as well as water droplet damage

STERILIZATION AND COOKING IN THE FOOD INDUSTRY

- Supply of steam near the saturation temperature to ensure a uniform heat transfer
- Accurate temperature control to ensure proper sterilization
- Exact control for short cooking times

SAMSON – OUR EXPERTISE

Engineered Solutions From a Single Source

Combined with valve accessories, control valves serve as engineered solutions for many process control applications. SAMSON has been developing and manufacturing high-quality valves, actuators and valve accessories for over 100 years. Our experience and expertise allows us to continuously develop our products to provide a complete solution for your application.



Actuators

SAMSON's multi-spring actuator provides a lightweight and compact design; the unique rolling diaphragm offers an exceptionally long life even through high cycle counts. Our actuators can be built, designed, painted, and coated to be suitable for all forms of environmental conditions, from general service to highly corrosive environments.



Positioners

Our positioners are designed to enhance the performance, reliability, and serviceability of any valve in process control applications. The SAMSON product portfolio covers the full range of positioner types. From the pneumatic and analog electro-pneumatic positioners that have been trusted for decades, to fully digital devices utilizing automatic calibration, central communications, and the most advanced monitoring and diagnostics.



Limit Switches

The limit switch product portfolio offers solutions for applications where indication is required when the valve travel exceeds or falls below a pre-defined limit. Available options include inductive, electric, pneumatic or software contacts and can contain up to three switches depending on the device. Limit switches can be used for switching control signals, providing audible/visual notification, or for connection to central control or alarm systems.



Solenoid Valves

SAMSON solenoid valves offer a high level of reliability for pneumatic switching applications with the added benefit of minimal power consumption. Commonly used for the opening and closing of valves in basic process control and safety systems (SIS), they are available in a wide variety of configurations including 3/2, 5/2, 5/3 or 6/2-way functions to suit any application.

TECHNICAL DETAILS

Valve Size	<ul style="list-style-type: none"> ■ NPS 2 to 12 (3281 Globe Valve) ■ NPS 2 to 12 (3286 Angle Valve)
Pressure Rating	ANSI Class 150 to 900
End Connections	<ul style="list-style-type: none"> ■ RF Flanged (ASME B16.5) ■ Welding Ends (B16.25)
Materials	<ul style="list-style-type: none"> ■ Carbon Steel (A216 WCC) ■ High Temperature Steel (A217 WC6)
Temperature Range	Up to 932°F (500°C)
Outlet Temperature	At least 9°F (5°C) above the saturated steam temperature, depending on the process conditions
Cooling Water Temperature	At least 68°F (20°C), depending on the process conditions

SAMSON's technology has proven its value worldwide in a variety of industries. We are trusted in many of the world's most challenging applications to achieve precise control with a high level of safety and reliability.

The SAMSON product portfolio offers engineered solutions from a single source. With our extensive range of valves, actuators, and accessories we have the right products to suit your requirements.

Our linear and rotary control valves are carefully selected and sized to ensure reliable operation with reduced maintenance requirements. The latest in positioner technology offers precise control, seamless

integration into process control systems, and advanced diagnostics to allow for predictive maintenance.

The modular design of our products allows customers to benefit from a tailor-made solution at an affordable cost. Furthermore, the interchangeability of spare parts between different valve models and sizes contributes to keeping inventory costs low.

Continuous investment in research and development allows us to stay at the cutting edge of technology. With over 100 years of experience and expertise, you can count on SAMSON to provide a robust solution for your application.

SAMSON
PFEIFFER · RINGO · SED · STARLINE · VETEC
 AIR TORQUE · CERA SYSTEM · LEUSCH

SAMSON Controls Inc.

4111 Cedar Blvd. Baytown, TX 77523-8588 USA
 Phone: +1 281-383-3677 · Fax: 281-383-3690



www.samsoncontrols.com



contact-us@samsongroup.com