

MOUNTING AND OPERATING INSTRUCTIONS



EB 9510 EN

Translation of original instructions



Media 7 Differential Pressure Meter with remote data transmission

Firmware version 1.02.07



Edition September 2018

Note on these mounting and operating instructions

These mounting and operating instructions assist you in mounting and operating the device safely. The instructions are binding for handling SAMSON devices.

- For the safe and proper use of these instructions, read them carefully and keep them for later reference.
- If you have any questions about these instructions, contact SAMSON's After-sales Service (aftersalesservice@samsongroup.com).



The mounting and operating instructions for the devices are included in the scope of delivery. The latest documentation is available on our website at www.samsongroup.com > **Service & Support** > **Downloads** > **Documentation**.

Definition of signal words

DANGER

Hazardous situations which, if not avoided, will result in death or serious injury

WARNING

Hazardous situations which, if not avoided, could result in death or serious injury

NOTICE

Property damage message or malfunction

Note

Additional information

Tip

Recommended action

1	Safety instructions and measures	5
1.1	Notes on possible severe personal injury	7
1.2	Notes on possible personal injury	8
1.3	Notes on possible property damage	10
2	Markings on the device	12
2.1	Nameplate	12
2.2	Article code	14
3	Design and principle of operation	16
3.1	Configuration using the TROVIS-VIEW software	16
3.2	Application	18
3.2.1	Differential pressure measurement	18
3.2.2	Liquid level measurement	18
3.2.3	Device arrangement for liquid level measurement	19
3.3	Versions	20
3.3.1	Two-wire version	20
3.3.2	24 V version	20
3.4	Device overview and operating controls	20
3.5	Accessories	22
3.5.1	Valve block	22
3.5.2	Further accessories	22
3.6	Technical data	24
3.7	Dimensions in mm	29
3.7.1	Dimensions for mounting (mm)	30
4	Measures for preparation	31
4.1	Unpacking	31
4.2	Transporting and lifting	31
4.2.1	Transporting	31
4.3	Storage	31
5	Mounting and start-up	32
5.1	Preparation for installation	32
5.2	Mounting the Media 7 device	32
5.3	Connecting the measuring lines	34
5.4	Electrical connections	35
5.4.1	Cable glands and terminals	35
5.4.2	Connecting the wiring	36

6	Optional additional function	38
6.1	Option modules	39
6.1.1	Nameplate	39
6.1.2	Slots for option modules	40
6.1.3	Inserting or removing option modules	42
6.2	GSM module	44
6.2.1	Nameplate	44
6.2.2	Installing the GSM module	46
6.2.3	Aligning the antenna	48
6.3	Standby power supply (SPS)	49
6.3.1	Inserting the battery	50
7	Operation	52
7.1	Capacitive keys	52
7.2	Display	53
7.3	Examples for the operation of the Media 7 device	54
8	Operation of Media 7 Differential Pressure Meter	58
8.1	First start-up	58
8.1.1	Running the start-up wizard	58
8.1.2	Option module wizard	60
8.1.3	Setting the user level	60
8.1.4	Performing zero calibration	61
8.2	Calibrating the measuring range (span)	63
8.3	Remote data transmission	66
8.3.1	Status LEDs of the GSM module	66
9	Servicing	67
9.1	Servicing explosion-protected devices	67
9.2	Preparation for return shipment	68
9.3	Firmware update	68
10	Malfunctions	69
11	Decommissioning and removal	71
11.1	Decommissioning	71
11.2	Removing the differential pressure meter	71
11.3	Disposal	71
12	Annex	72
12.1	After-sales service	72
12.2	Menu structure and parameters	73

1 Safety instructions and measures

Intended use

The Media 7 Differential Pressure Meter is a microprocessor-controlled transmitter with dp cell for measuring, indicating and transmitting the differential pressure, pressure or measured variables derived from them. The device is suitable for cryogenic gases, liquids, gases and vapors. The device is designed to operate under exactly defined conditions (e.g. operating pressure, process medium, temperature). Therefore, operators must ensure that the device is only used in operating conditions that meet the specifications used for sizing the device at the ordering stage.

The Media 7 device can be operated in hazardous areas in Zone 1 or higher only. The measurement of flammable or explosive media is only permitted with the following approvals:

- Type 5007-1-120x (ATEX): II 1/2G Ex ia IIB T4 Ga/Gb
- Type 5007-1-121x (IECEX): Ex ia IIB T4 Ga/Gb (IECEX)

In case operators intend to use the device in other applications or conditions than specified, contact SAMSON.

SAMSON does not assume any liability for damage resulting from the failure to use the device for its intended purpose or for damage caused by external forces or any other external factors.

➔ Refer to the technical data for limits and fields of application as well as possible uses.

Reasonably foreseeable misuse

The Media 7 Differential Pressure Meter is **not** suitable for the following applications:

- Use outside the limits defined during sizing and by the technical data

Furthermore, the following activities do not comply with the intended use:

- Use of non-original spare parts
- Performing maintenance activities not specified by SAMSON

Qualifications of operating personnel

The device must be mounted, started up and serviced by fully trained and qualified personnel only; the accepted industry codes and practices are to be observed. According to these mounting and operating instructions, trained personnel refers to individuals who are able to judge the work they are assigned to and recognize possible hazards due to their specialized training, their knowledge and experience as well as their knowledge of the applicable standards.

Safety instructions and measures

Explosion-protected versions of this device must be operated only by personnel who has undergone special training or instructions or who is authorized to work on explosion-protected devices in hazardous areas.

Personal protective equipment

We recommend wearing the following protective equipment depending on the process medium:

- Protective clothing, gloves, eye protection and respiratory protection in applications with hot, cold and/or corrosive media
- ➔ Check with the plant operator for details on further protective equipment.

Revisions and other modifications

Revisions, conversions or other modifications of the product are not authorized by SAMSON. They are performed at the user's own risk and may lead to safety hazards, for example. Furthermore, the product may no longer meet the requirements for its intended use. Use of the device is no longer permitted.

Warning against residual hazards

To avoid personal injury or property damage, operators and operating personnel must prevent hazards that could be caused in the device by the process medium and operating pressure by taking appropriate precautions. They must observe all hazard statements, warning and caution notes in these mounting and operating instructions, especially for installation, start-up and service work.

Responsibilities of the operator

The operator is responsible for proper operation and compliance with the safety regulations. Operators are obliged to provide these mounting and operating instructions to the operating personnel and to instruct them in proper operation. Furthermore, the operator must ensure that operating personnel or third persons are not exposed to any danger.

Responsibilities of operating personnel

Operating personnel must read and understand these mounting and operating instructions as well as the specified hazard statements, warning and caution notes. Furthermore, the operating personnel must be familiar with the applicable health, safety and accident prevention regulations and comply with them.

Referenced standards and regulations

Devices with a CE marking fulfill the requirements of the Directives 2014/30/EU and 2014/34/EU. The declarations of conformity are included at the end of these instructions.

Referenced documentation

The following documents apply in addition to these mounting and operating instructions:

- Mounting and operating instructions for mounted pipeline valves (strainers, shut-off valves etc.)

1.1 Notes on possible severe personal injury



Risk of fatal injury due to the formation of an explosive atmosphere.

Incorrect installation, operation or maintenance of the differential pressure meter in potentially explosive atmospheres may lead to ignition of the atmosphere and cause death, even with a harmless supply voltage.

- For mounting and electrical installation in hazardous areas, observe the explosion protection approvals as well as the relevant electrotechnical regulations and the accident prevention regulations that apply in the country of use. EN 60079-14 applies in Europe.
- Do not connect the supply voltage before mounting is completed and any unused cable entries have been sealed.
- Installation, operation or maintenance of the differential pressure meter must only be performed by personnel with qualifications according to Clause 4.5 of IEC 60079-14 who has undergone special training or instructions or who is authorized to work on explosion-protected devices in hazardous areas.

⚠ DANGER

Risk of fatal injury as a result of electrostatic discharge at the housing.

The housing of the Media 7 device is made of polycarbonate and may become electrostatically charged when handled improperly. An electric spark generated by electrostatic discharge may lead to ignition of a potentially explosive atmosphere and cause death.

- Ensure that the device, cables and other plant components cannot rub against each other.
- Do not rub dry the housing surface of the Media 7 device.
- Only use a damp cloth or wipes (e.g. with diluted mild soap or detergent) to clean the housing surface.

Risk of bursting in pressure equipment.

The dp cell of the Media 7 device and pipelines are pressure equipment according to Directive 2014/68/EU. Improper opening can lead to leakage or bursting of plant or device components.

- Before starting any work on the Media 7 device, depressurize all plant sections concerned and the dp cell.
- Drain the process medium from all the plant sections affected as well as the dp cell.
- Wear protective clothing as specified in the material safety data sheet (MSDS) of the medium used.

1.2 Notes on possible personal injury

⚠ WARNING

Incorrect electrical connection will render the explosion protection unsafe.

- Only operate the device with an intrinsically safe power supply while complying with the maximum permissible values for U_i or U_0 , I_i or I_0 and P_i or P_0 .
- Adhere to the terminal assignment and correct polarity.
- Do not undo the enameled screws.

⚠ WARNING

Risk of personal injury due to residual process medium in the dp cell.

While working on the dp cell, residual process medium can escape and, depending on its properties, may lead to personal injury, e.g. (chemical) burns.

- Drain the process medium from all the plant sections concerned and the dp cell, if possible.
- Wear protective clothing, safety gloves and eye protection.

Risk of personal injury due to medium escaping from a damaged dp cell.

Ensure that all parts (including the dp cell) that come into contact with the process medium are made of materials with long-term durability.

- Only use process media which, according to their properties, are compatible with the materials used in the device.
- Observe the material numbers listed in the technical data as well as the material safety data sheets (MSDS) of the process media.

Risk of burn injuries due to hot or cold components and pipelines.

Depending on the process medium, valve components and pipelines may get very hot or cold and cause burn injuries.

- Allow components and pipelines to cool down or heat up.
- Wear protective clothing and safety gloves.
- Devices intended to measure gaseous oxygen are labeled as follows:



Cleaned and degreased for oxygen according to:
 ISO 23208 - cleaned oxygen
 Inspection procedure according to appendix: A.2 and A.3

These versions are cleaned and assembled under special conditions. When replacing parts that come into contact with gaseous oxygen, wear suitable gloves and make sure that the parts do not come into contact with oil or grease.

- When returning devices for oxygen service for repair, the sender assumes full responsibility that the devices are handled to meet all requirements stipulated by VBG 62 or similar regulations until they are handed over to the manufacturer. Otherwise, SAMSON does not accept any responsibility.

1.3 Notes on possible property damage

! NOTICE

Risk of dp cell damage due to contamination (e.g. solid particles) in the pipeline.

The plant operator is responsible for cleaning the pipelines in the plant.

→ Observe the maximum permissible pressure for dp cell and plant.

Risk of damage to the differential pressure meter due to the maximum permissible values specified in the EC type examination certificate being exceeded.

The plant operator is responsible for cleaning the pipelines in the plant.

→ Do not exceed the maximum permissible values (U_i or U_o , I_i or I_o , P_i or P_o , C_i or C_o and L_i or L_o) when interconnecting intrinsically safe electrical equipment.

Risk of dp cell damage due to unsuitable medium properties.

The device is designed for process media with defined properties.

→ Only use process media suitable for the device version according to the article code (see page 15).

Risk of damage to the dp cell due to incorrect use with oxygen.

When liquid oxygen is used as the process medium, the permissible temperature range is exceeded.

→ When the device is used for oxygen service, make sure that the dp cell and any SAMSON accessories (e.g. valve block) only come into contact with **gaseous oxygen**.

→ The maximum permissible oxygen pressure is 50 bar.

Risk of leakage and dp cell damage due to excessively high or low tightening torques.

Observe the specified torques on tightening connecting parts of the dp cell. Excessively tightened torques lead to parts wearing out quicker. Parts that are too loose may cause leakage.

→ Observe tightening torques.

! NOTICE

An incorrect electrical power supply will damage the electronics.

The Media 7 device is designed to operate under exactly defined electrical conditions.

- Observe the permissible tolerances of the supply voltage.
- For wiring, you are required to observe the relevant regulations concerning device safety and electromagnetic compatibility.

Risk of damage to the device due to incorrect mounting position.

- Mount the device in the upright position only.

Incorrect installation or removal of the option modules will damage the differential pressure meter.

- Before inserting or removing the option modules, disconnect the power supply.

2 Markings on the device

2.1 Nameplate

Two-wire version (explosion-protected):

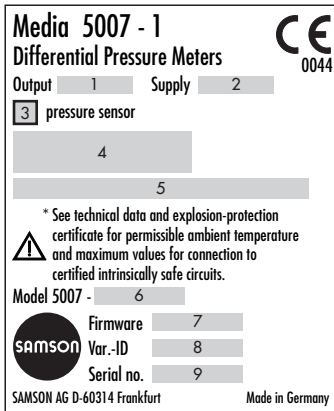

Two-wire version (without explosion protection):

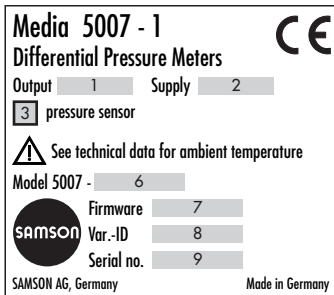

24 V version:

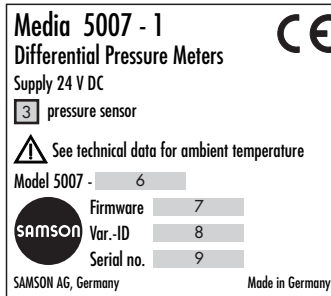

- 1 Signal range
- 2 Electric power supply
- 3 Pressure sensor (yes/no)¹⁾
- 4 Type of protection for explosion-protected devices
- 5 Temperature limits in the test certificates for the explosion-protected devices
- 6 Model number
- 7 Firmware version
- 8 Configuration ID
- 9 Serial number²⁾
- 10 International Mobile Equipment Identity³⁾
- 11 Pressure rating
- 12 Measuring range
- 13 Optional additional function
- 14 Ordering number
- 15 Abbreviation of optional additional function
- 16 QR code
- 17 Activation code

¹⁾ There is no pressure sensor in devices used with flammable gases. Therefore, it is not specified on the nameplate.

²⁾ The first two figures of the serial number in reverse order indicate the year of manufacture (example: serial number 71xxxx → Year of manufacture = 2017).

³⁾ 15-digit serial number for unique identification of mobile devices

dp cell:

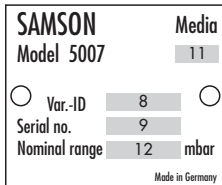

GSM module (see section 6.2):

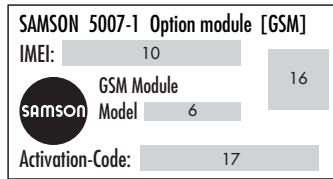

Option module without explosion protection (see section 6.1):

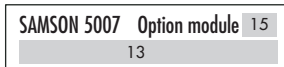

Option module with explosion protection (see section 6.1):

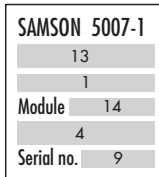

2.2 Article code

Media 7	5007-1- x x x x x x x x x 0 x x x x x x x x												
With 4" LCD													
Explosion protection													
Without	0	0	0	1									
ATEX: II 2G Ex ia IIB T4 Gb	1	1	0										
IECEX: Ex ia IIB T4 Gb	1	1	1										
ATEX: II 1/2G Ex ia IIB T4 Ga/Gb	1	2	0										
IECEX: Ex ia IIB T4 Ga/Gb	1	2	1										
Energy supply													
Two-wire				0									
Power supply unit, 24 to 36 V DC				1									
Option module slot 1													
Without				0									
AO: Analog output				5									
AI: Analog input				4									
AIA: Analog input active				6									
Option module slot 2													
Without				0									
AO: Analog output				5									
AI: Analog input				4									
AIA: Analog input active				6									
Option module slot 3													
Without				0									
AO: Analog output				5									
AI: Analog input				4									
AIA: Analog input active				6									
Option module slot 4													
Without				0									
AO: Analog output				5									
AI: Analog input				4									
AIA: Analog input active				6									

Media 7		5007-1- x x x x x x x x x 0 x x x x x x x x									
GSM module with antenna											
Without	0										
GSM module with antenna (including SIM card)		2									
dp cell material											
Brass	0										
Measuring range											
160 mbar		0	2								
600 mbar		0	5								
1600 mbar		0	7								
3600 mbar		0	9								
Diaphragm											
ECO: -40 to +80 °C, REACH compliant						0					
Version											
Version for cryogenic gases according to DIN EN ISO 23280, packed in plastic bags, free of oil and grease according to company standard WN 1.34-2 Sheets 1 and 1.1								1	1		
Version for oxygen according to DIN EN ISO 25208, packed in plastic bags, free of oil and grease according to company standard WN 1.34-2 Sheets 1 and 1.1								1	2		
Pressure rating											
50 bar, version for oxygen service, without valve block										1	
60 bar, without valve block										2	
50 bar, with valve block PN 50										3	
Pressure sensor											
Without											1
With, non-flammable gases											2

3 Design and principle of operation

The Media 7 device is a microprocessor-controlled transmitter with dp cell for measuring, indicating and transmitting the differential pressure, pressure or measured variables derived from them in stationary pressure vessels and in transportation vehicles. The device is suitable for cryogenic gases, liquids, gases and vapors. Measuring ranges between 0 to 160 mbar and 0 to 3600 mbar, nominal pressure PN 60.

The device mainly consists of a dp cell (1), housing with transmitter and a display (6).

The differential pressure $\Delta p = p_1 - p_2$ is converted into an electric signal in the dp cell by a sensor and processed in the microcontroller (2) which controls the display and D/A converter of the two-wire version.

Four capacitive keys (4) are used to operate the differential pressure meter and allow the user to navigate within the menu on the display.

The modular design of the Media 7 device allows it to be adapted to specific requirements. Optional additional functions are available through the use of option modules (see section 6.1).

A remote data transmission using the optional GSM module (9) is possible in the 24 V version. Connection to the SAM TANK MANAGEMENT web interface is established over a mobile network (see section 6.2).

Operating mode

- **Differential pressure measurement** between flow and return flow pipe as well as pressure drop measurement across valves and filters
- **Liquid level measurement** in stationary pressure vessels and transportation vehicles

Power supply unit with standby power supply (SPS)

The power supply units include a battery compartment for a 1.5 V battery which provides standby power supply upon power failure (see section 6.3).

3.1 Configuration using the TROVIS-VIEW software

The differential pressure meter can be configured with SAMSON's TROVIS-VIEW Software (version 4). For this purpose, the differential pressure meter has a digital interface (SSP) to allow the USB port of a computer to be connected to it using an adapter cable.

The TROVIS-VIEW software enables the user to easily configure the differential pressure meter as well as view process parameters online.

i Note

TROVIS-VIEW can be downloaded free of charge from our website at www.samsongroup.com > Service & Support > Downloads > TROVIS-VIEW.

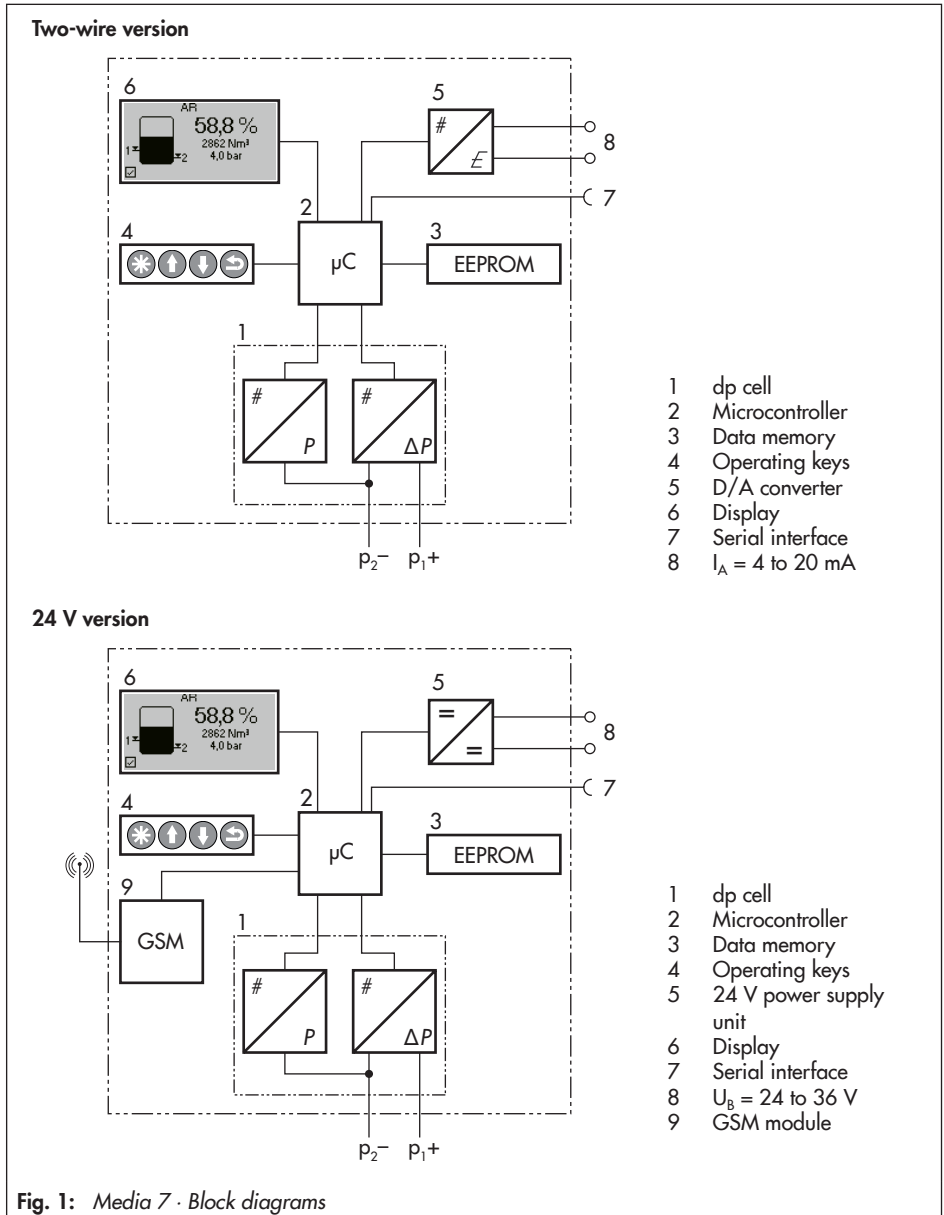

Fig. 1: Media 7 · Block diagrams

3.2 Application

The differential pressure of liquids, vapors and gases are measured by the integrated dp cell in the Media 7 device. The measured differential pressure is used for various possible applications.

3.2.1 Differential pressure measurement

Two absolute pressures p_1 and p_2 are compared for the differential pressure measurement. This way, for example the filters can be monitored by measuring the upstream and downstream pressures at the filter.

3.2.2 Liquid level measurement

The tank content (function of hydrostatic pressure, tank geometry and liquid density of the stored gas) is displayed proportionally and the operating pressure is indicated in the selected unit on the display. Fig. 2 illustrates the principle of the liquid level measurement.

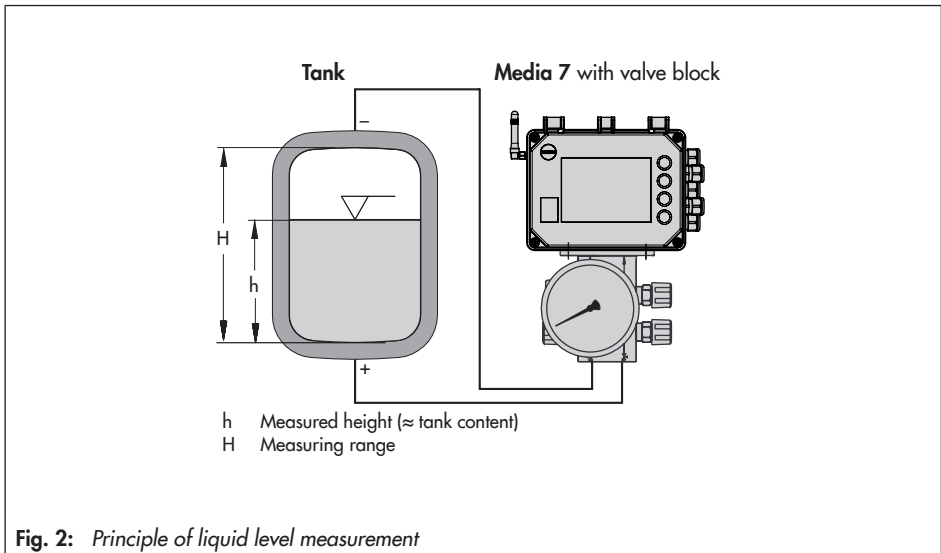

3.2.3 Device arrangement for liquid level measurement

- Fig. 3, diagram 1: measurement on cryogenic tanks
- Fig. 3, diagram 2: measurement on pressure vessels with condensing or non-condensing pressure reserve. The additional height z is included in the measurement. As a result, this height (z) must be as low as possible.
- Fig. 3, diagram 3: measurement on open vessels with the meter located in a low position. The compensation height K can be as large as required depending on the conditions in the plant.

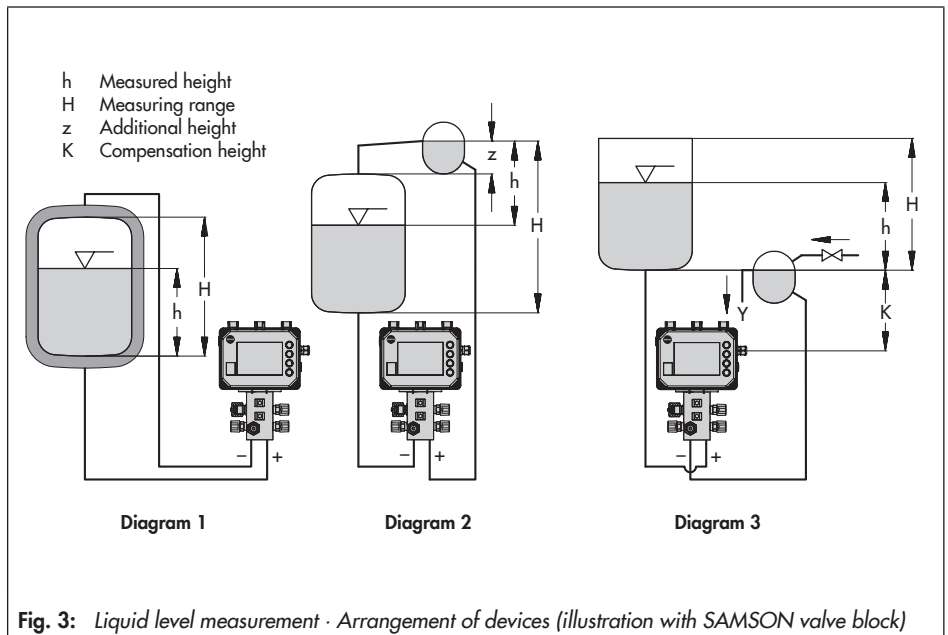

3.3 Versions

3.3.1 Two-wire version

– **Type 5007-1-000x...**

To operate the two-wire version, a transmitter supply voltage for the 4 to 20 mA current loop is required ($U_B = 12$ to 36 V DC for the version without explosion protection).

– **Type 5007-1-1xx0...**

To operate the two-wire version, a transmitter supply voltage for the 4 to 20 mA current loop is required ($U_B = 12$ to 28 V DC for the version with explosion protection).

The current loop must be supplied only by a supply unit which has an equivalent or higher explosion protection approval. Its electrical connection data must be lower or identical to those in the explosion protection certificate of the Type 5007-1-1xx0 device.

3.3.2 24 V version

– **Type 5007-1-xxx1...**

The 24 V version has a wider ambient temperature range. Due to the greater electrical power, it has additional functions, such as illuminated display and remote data transmission through the use of a retrofittable GSM module.

3.4 Device overview and operating controls

→ See Fig. 4

- 1 Display
- 2 Confirm key
- 3 Up arrow key
- 4 Down arrow key
- 5 Back key
- 6 Error LED
- 7 Battery LED (SPS)
- 8 Status LEDs for GSM module
- 9 Signal input terminal
- 10 Slot for GSM module
- 11 SSP interface
- 12 Slots 1 to 4 for option modules
- 13 SPS: standby power supply
- 14 Grounding connection

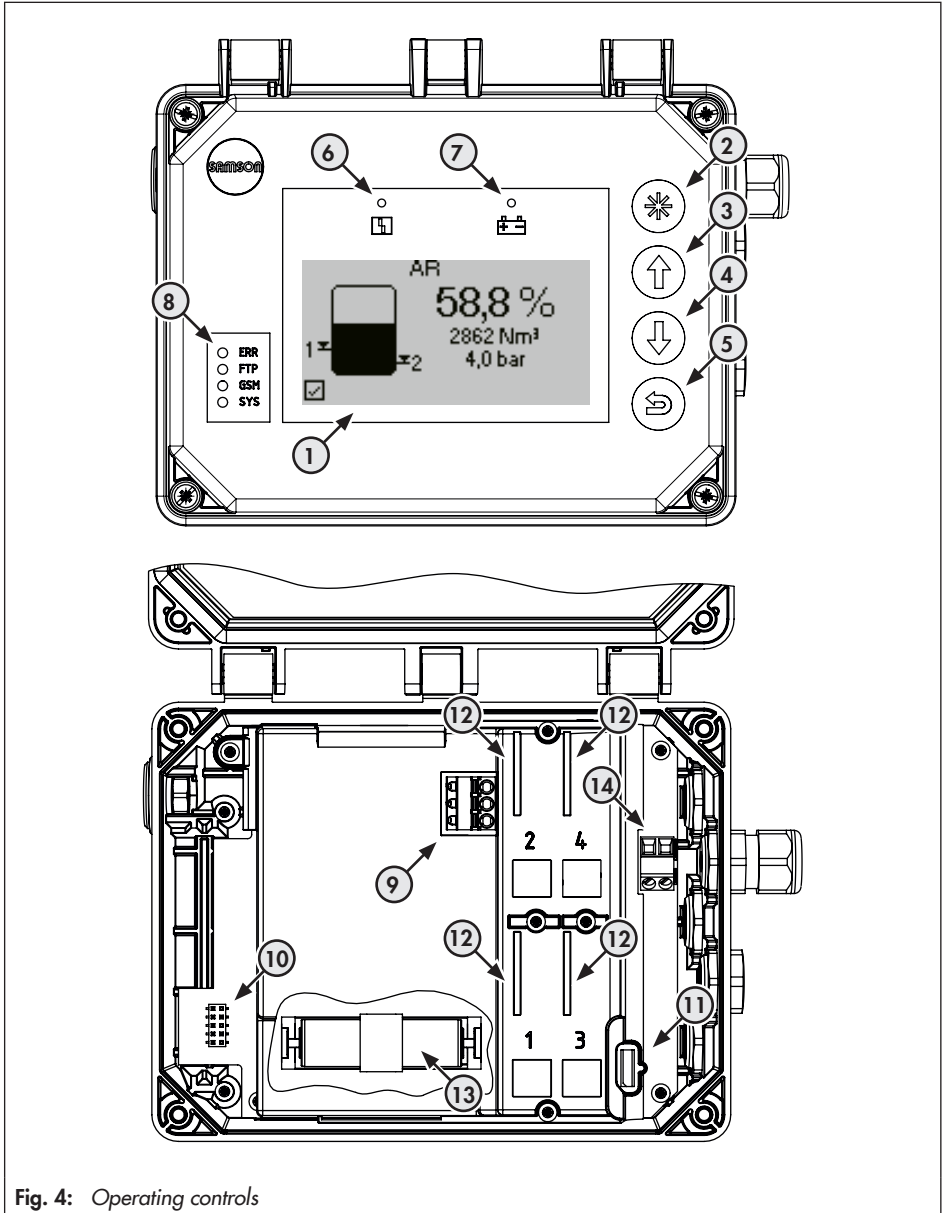

Fig. 4: Operating controls

3.5 Accessories

3.5.1 Valve block

Three valves are combined in the valve block for Media 7. The valve block is bolted onto the bottom of the Media 7 dp cell (see Fig. 5).

The valve block offers the following benefits:

- Mounting of an operating pressure gauge possible.
- Fastened using two additional mounting holes.
- The connected process lines can be bypassed. This allows a zero calibration to be performed regardless of the current filling level of the tank.
- The differential pressure meter can be easily removed by shutting off the measuring lines (e.g. to replace a defective device) without disturbing the running process.
- Lead-seal holes

➔ Details on the valve block:
see accessories for the Media Series

▶ T 9555

3.5.2 Further accessories

A list of available accessories for the Media Series can be found in the Data Sheet

▶ T 9555.

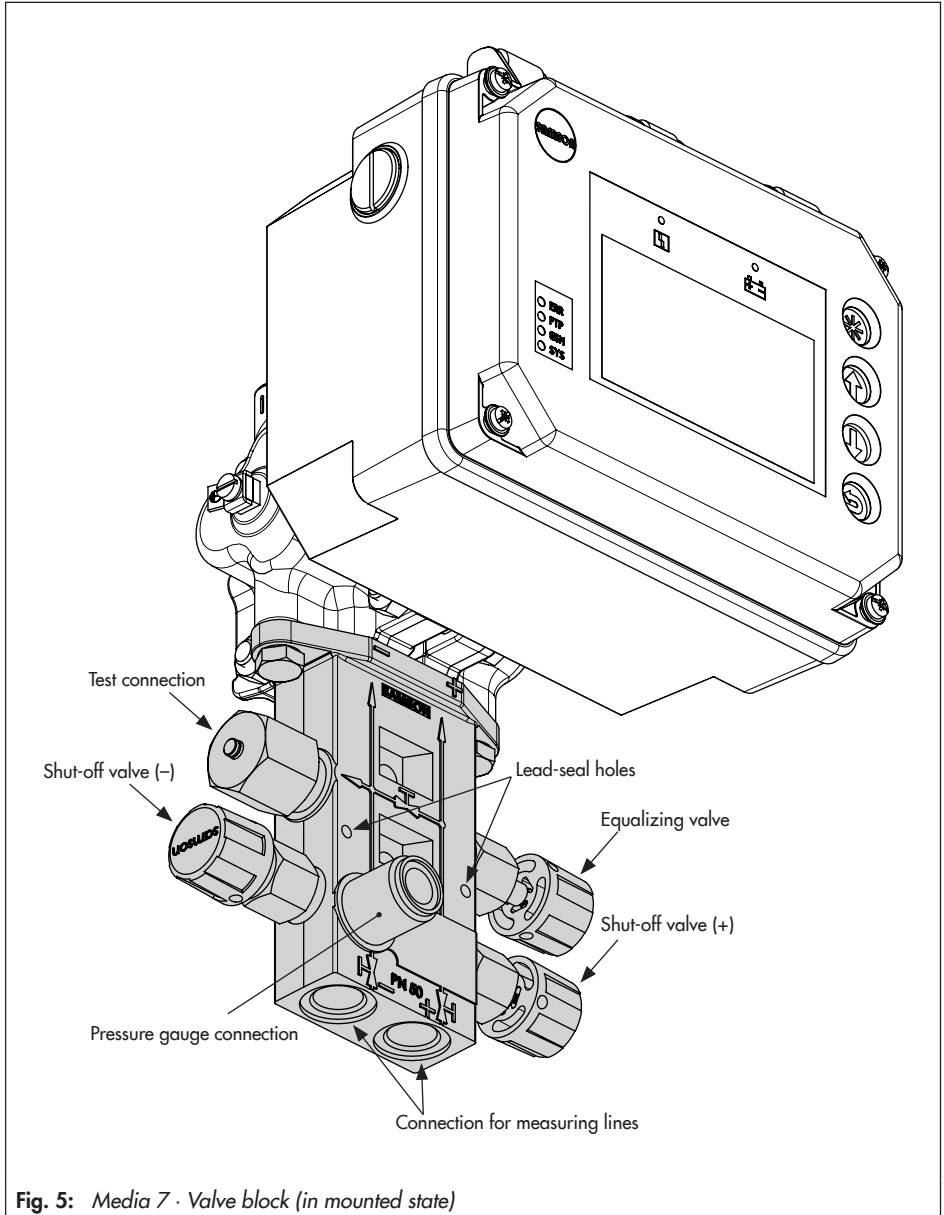

3.6 Technical data

Table 1: General technical data

Media 7 Differential Pressure Meter (All pressure in bar (gauge); all errors and deviations are specified in % of the adjusted measuring span)				
Mounting position	Upright with display facing sideways			
Principle of operation	The differential pressure at the diaphragm is converted into an electric signal by the AMR system.			
Pressure rating	PN 60, overloadable on one side up to 60 bar Oxygen: PN 50, overloadable on one side within the adjusted system pressure			
Characteristic	Differential pressure proportional to the tank geometry			
Deviation from terminal-based linearity	<±1.6 % (including hysteresis)			
Sensitivity	≤0.25 % or <±0.5 % depending on measuring span selected			
Effect of static pressure	<0.03 %/1 bar			
Display				
Display	LCD 128 x 64 (90 x 40 mm)			
Storage temperature	-40 to approx. +80 °C			
Operating temperature	Two-wire version: -20 to approx. +70 °C 24 V version: -40 to +70 °C			
Measuring range in mbar	0 to 160	0 to 600	0 to 1600 ¹⁾	0 to 3600 ¹⁾
Adjustable measuring span in mbar				
Class ±1 %	-	≤630 to ≥150	≤1700 ¹⁾ to ≥320	≤3800 ¹⁾ to ≥720
Class ±1.6 %	≤170 to ≥60	≤150 to ≥120	-	-
Effect of ambient temperature in the range from -20 to +70 °C				
On zero in %/10 K	<±0.4	<±0.1	<±0.1	<±0.1
On span in %/10 K	<±0.4	<±0.1	<±0.1	<±0.1
Internal absolute pressure sensor				
Measuring range	0 to 60 bar			
Deviation from terminal-based linearity	<±1.6 %			
Effect of ambient temperature	≤0.018 % (within the range from -20 to +70 °C)			

¹⁾ A class accuracy of 0.6 % can be expected in these measuring ranges with measuring spans ≤100 % to ≥75 % of the nominal range.

Environmental influences	
Storage according to EN 60721-3-1 (long-term storage)	1K5 (air temperature -40 to $+80$ °C); 1M3 (The following restriction applies to GSM module: air temperatures -30 to $+75$ °C)
Transportation according to EN 60721-3-2	2K4 (air temperature -40 to $+40$ °C in ventilated enclosures, up to $+70$ °C in unventilated enclosures), 2M1 (The following restriction applies to GSM module for low air temperatures down to -30 °C)
Operation according to EN 60721-3-4 (stationary use at non-weather-protected locations)	4K4 (with restrictions: air temperature -40 to $+55$ °C, temperature inside the housing must not exceed $+70$ °C when exposed to direct sunlight); 4M4 <ul style="list-style-type: none"> - The display and GSM module are heated at low air temperatures (24 V version). - The restrictions for the oxygen testing additionally apply to versions for oxygen service: 50 bar/$+60$ °C. - Observe the limits in the test certificate for explosion-protected versions.
Mechanical vibration	
Vibrations (sinusoidal) according to IEC 60068-2-6	2 to 9 Hz; 3.5 mm amplitude 9 to 200 Hz; 10 m/s ² acceleration 200 to 500 Hz; 15 m/s ² acceleration
Random and guidance vibration according to IEC 60068-2-64	1.0 m ² /s ³ ; 10 to 200 Hz 0.3 m ² /s ³ ; 200 to 2000 Hz
Shocks according to IEC 60068-2-27	Acceleration 100 m/s ² ; duration 11 ms
Requirements	
EMC	Devices with a CE marking fulfill the requirements of the Directive 2014/30/EU. Compliance with EN 61000-6-2, EN 61000-6-3, EN 61326-1 and NAMUR Recommendation NE 21.
Degree of protection	IP 67 according to IEC 60529 (VDE 470 Part 1, 2014-09)
Explosion protection	
Type of protection	ATEX/IECEx: Ex ia IIB T4 Gb Devices with a CE marking fulfill the requirements of the Directive 2004/34/EU.
Oxygen service	
Gaseous oxygen (process medium)	Operating temperature from -40 to $+60$ °C at max. 50 bar operating pressure (applies to parts inside and on the device which are included in the oxygen testing)
Electrical connections	
Cable glands	M16 x 1.5 (max. 5)
Terminals	0.2 to 2.5 mm ² wire cross-section
Spring-cage terminals (option modules)	0.13 to 1.5 mm ² wire cross-section

Design and principle of operation

Communication	
Local	SAMSON SSP interface and serial interface adapter, TROVIS-VIEW
Remote data transmission	GSM module
Weight	
Device without valve block	Approx. 3300 g
Device with valve block (without pressure gauge)	Approx. 5200 g

Table 2: Power supply

Optional power supply					
Two-wire version	5007-1-0000	5007-1-1100	5007-1-1110	5007-1-1200	5007-1-1210
	Explosion protection	No explosion protection	ATEX Ex ia	IECEx Ex ia	ATEX Ex ia
Output	4 to 20 mA				
Permissible load R_B in Ω	$R_B = (U_B - 12 \text{ V})/0.020 \text{ A}$				
Output circuit	–	Intrinsically safe according to EN/IEC 60079-11			
Power supply U_B for two-wire transmitter	12 to 36 V DC	12 to 28 V DC (only in conjunction with an intrinsically safe circuit)			
24 V version	5007-1-0001				
Input voltage	24 to 36 V DC				
Output voltage	12 V DC				
Power	24 W				
Version	Reverse polarity protection				

Table 3: Optional additional functions

AO: Analog output	
Version	Two-wire system, galvanic isolation, reverse polarity protection, reversible direction of action
Power supply	10 to 30 V DC
Output signal	4 to 20 mA
Operating range	3.8 to 20.5 mA (according to NAMUR Recommendation NE 43)
Error indication	3.4 or 21.6 mA
No-load current	1.36 mA
Static destruction limit	38 V DC · 30 V AC



AI: Analog input	
Version	4 to 20 mA current input, externally powered, galvanically isolated, reverse polarity protection
Load impedance	≤ 5.0 V external (corresponding to ≤ 200 Ω at 20 mA)
Measuring range	0.1 to 21.6 mA
Accuracy	≤ 0.5 %
Resolution	20 μ A
Effect of temperature	0.1 %/10 K
Static destruction limit	38 V DC · 30 V AC
AIA: Analog input active	
Version	4 to 20 mA current input, internally powered, reverse polarity protection
Load impedance	≤ 1 V internal (corresponds to ≤ 50 Ω at 20 mA)
Output voltage at the terminal	≥ 12 VDC to power external two-wire devices
Measuring range	0.1 to 21.6 mA
Accuracy	≤ 0.5 %
Resolution	20 μ A
Effect of temperature	0.1 %/10 K
Static destruction limit	38 V DC · 30 V AC
GSM module for remote data transmission	
GSM frequency	EGSM 850/900/1800/1900 MHz
Power output	Class 4 (2 W) with 850/900 MHz; Class 1 (1 W) with 1800/1900 MHz
Antenna connection	SMA connector in housing wall
Right-angle antenna	Type 2J010: SMA R/A male
Color	Black
Capacity	25 W
Impedance	50 Ω
Polarization	Vertical
Frequency	GSM (900 MHz), AMPS (824-894 MHz), ISM (868 MHz), DCS (1800 MHz), PCS (1900 MHz), 3G (UMTS 2.1 GHz)
SIM card	M2M Industrial Plug in High Temperature, operating temperature: -40 to $+105$ $^{\circ}$ C; Provider: Telefonica Germany GmbH
Operating temperature	-40 to $+70$ $^{\circ}$ C (with active heating control)
Storage temperature	-30 to $+75$ $^{\circ}$ C
Web interface	SAM TANK MANAGEMENT

Design and principle of operation

Table 4: Materials

dp cell	
dp cell housing, high-pressure and low-pressure chambers	Brass CW617N-H070 (according to DIN EN 12420)
Elastomers	Standard cryogenic gases, oxygen, flammable gases of Group I: ECO 60 Shore A Further versions: FPM/FKM, EPDM, NBR
Springs and diaphragm plate	Corrosion-resistant steel
Screw fitting of process connections	Corrosion-resistant steel A2-70 and A4-70
Screw plugs	Brass CW608N-R380
Electronics housing and indicating unit	
Housing	UV-stabilized polycarbonate
Screws (housing)	Corrosion-resistant steel
Cover (transparent)	UV-stabilized polycarbonate
Screw fastenings (cover)	Corrosion-resistant steel
Cable glands	Polyamide with NBR seal

Table 5: Summary of explosion protection approvals

	Certification	Type of protection/comments
Type 5007-1	-110  EU type examination certificate	Number KIWA 17ATEX0041X Date 2018-06-01 II 2 G Ex ia IIB T4 Gb
	-120  EU type examination certificate	Number KIWA 17ATEX0041X Date 2018-06-01 II 1/2 G Ex ia IIB T4 Ga/Gb
	-111 IECEX	Number IECEx KIWA 17.0020X Date 2018-06-01 Ex ia IIB T4 Gb
	-121 IECEX	Number IECEx KIWA 17.0020X Date 2018-06-01 Ex ia IIB T4 Ga/Gb

3.7 Dimensions in mm

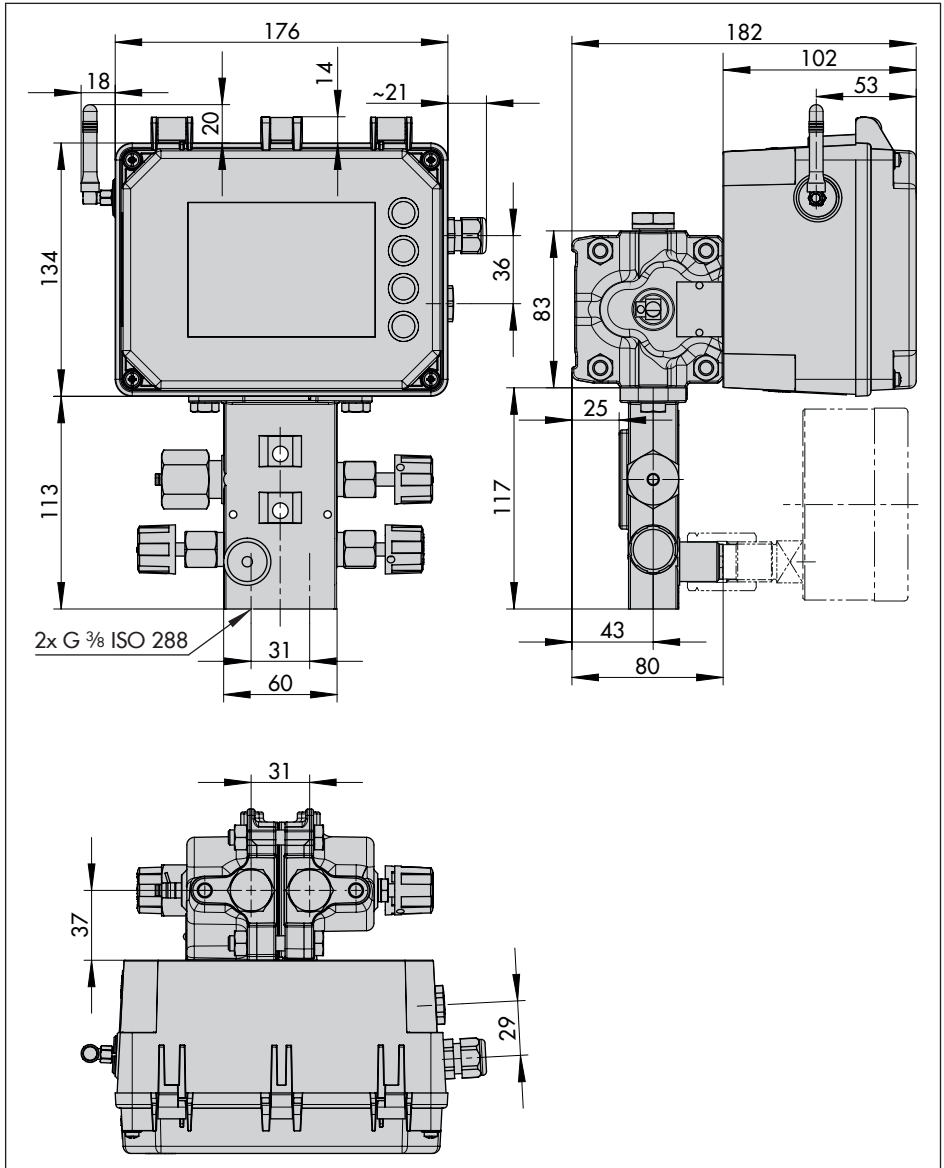

3.7.1 Dimensions for mounting (mm)

Dimensions with opened cover:

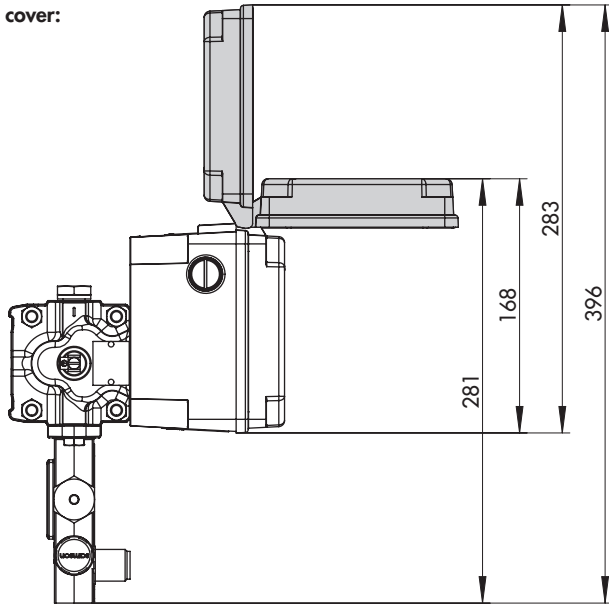

Drill pattern for wall/panel mounting:

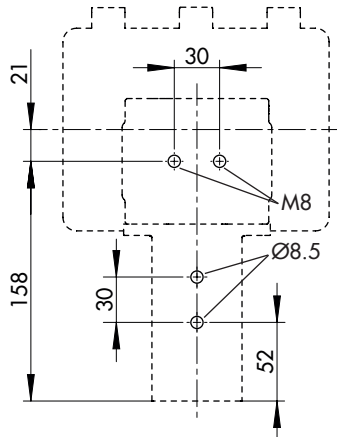

4 Measures for preparation

After receiving the shipment, proceed as follows:

1. Check the scope of delivery. Compare the shipment received with the delivery note.
2. Check the shipment for transportation damage. Report any transportation damage.

4.1 Unpacking

NOTICE

Risk of device damage due to foreign particles entering it.

Do not remove the packaging and protective film/protective caps until immediately before mounting and start-up.

1. Remove the packaging from the device.
2. Dispose of the packaging in accordance with the valid regulations.

4.2 Transporting and lifting

4.2.1 Transporting

- Check whether a battery is inserted in the differential pressure meter and remove it before transporting the device.
- Protect the device against external influences (e.g. impact).
- Protect the device against moisture and dirt.

- Observe the permissible transportation temperature of -20 to $+70$ °C.

4.3 Storage

NOTICE

Risk of device damage due to improper storage.

- Observe the storage instructions.
- Avoid long storage times.
- Contact SAMSON in case of different storage conditions or long storage periods.

Storage instructions

- Protect the Media 7 device against external influences (e.g. impact).
- Protect the Media 7 device against moisture and dirt.
- Make sure that the ambient air is free of acids or other corrosive media.
- Observe the permissible storage temperature from -20 to $+70$ °C.
- Do not place any objects on the device.

5 Mounting and start-up

NOTICE

Risk of damage to the device due to incorrect mounting position.

- *Keep rear blow-out opening clear.*
- *Mount the device in the upright position only:*

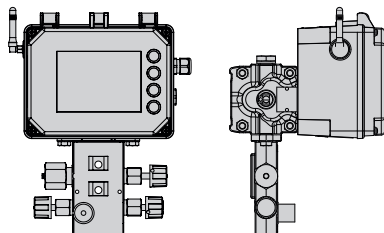

5.1 Preparation for installation

Proceed as follows:

- Flush the pipeline thoroughly before installation of the Media 7 device.
- Check the Media 7 device to make sure that it is clean and not damaged.

Note

The plant operator is responsible for cleaning the pipelines in the plant.

5.2 Mounting the Media 7 device

The following options to mount the Media 7 in the plant are available:

- Two M8 tapped holes in the dp cell (see Fig. 6, 1)
 - Two through holes for M8 screws in the valve block (see Fig. 6, 2)
- Mounting material for pipe and wall mounting as accessories (▶ T 9555)
- Drill pattern for wall/panel mounting: see section 3.7.

Additional points that apply concerning installation:

- Mount the device to a pipe, wall or mounting plate free of vibration.
- Use mounting part with clamp for pipe mounting to attach it to a vertical or horizontal pipe.
- Use a mounting part without clamp for wall mounting.

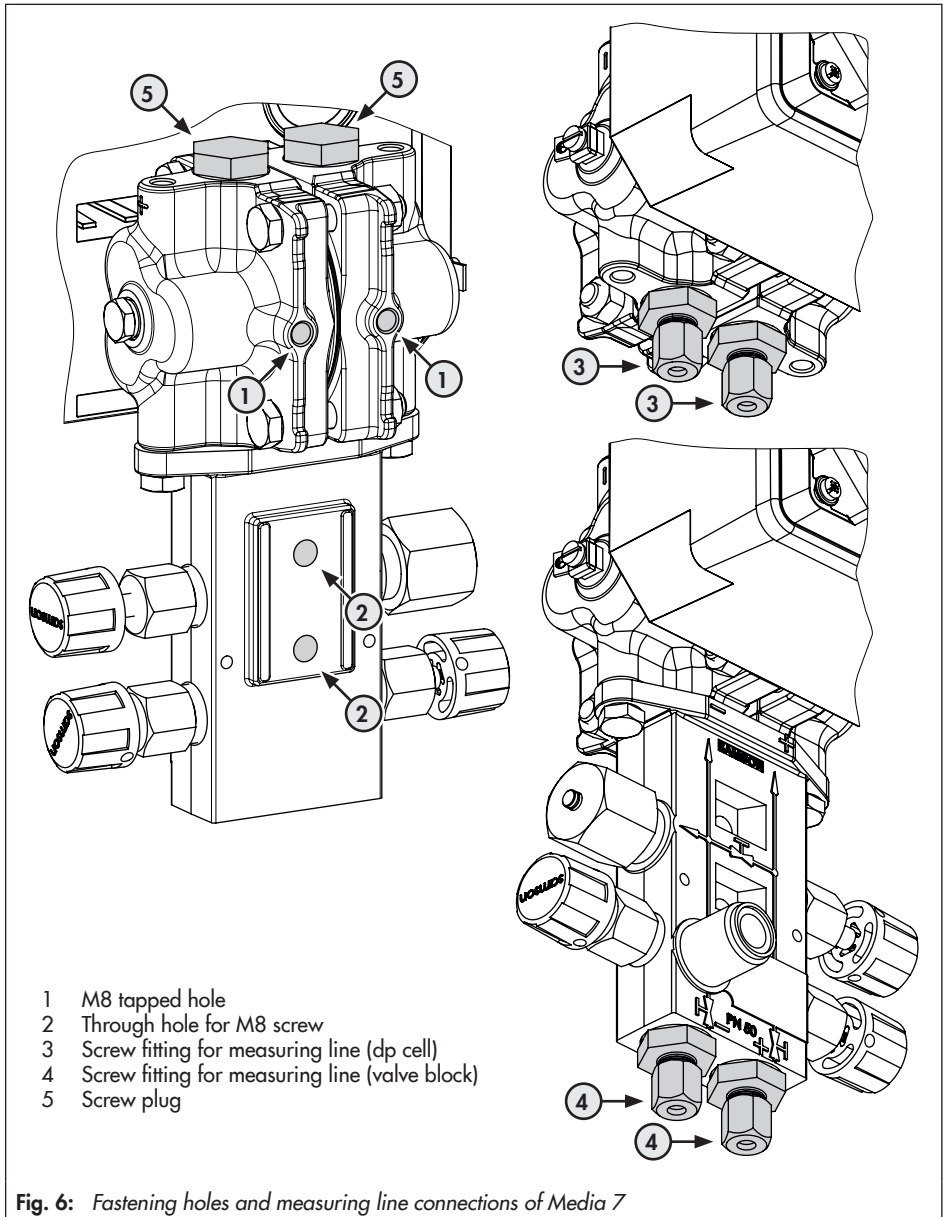

5.3 Connecting the measuring lines

i Note

*In following, pressurized lines are designated "**measuring lines**".*

! NOTICE

Risk of malfunction and incorrect measurements due to mixing up the measuring lines. Make sure that the high-pressure line is connected to the high-pressure connection and the low-pressure line to the low-pressure connection.

- Screw fittings are required to connect the measuring lines (see Fig. 6, 3/4 as well as accessories for Media Series ▶ T 9555).
- Depending on the device arrangement, seal the device connections that are left unused with screw plugs (see Fig. 6, 5 as well as accessories ▶ T 9555).

5.4 Electrical connections

⚠ DANGER

Risk of fatal injury due to the formation of an explosive atmosphere.

For mounting and electrical installation in hazardous areas, observe the explosion protection approvals as well as the relevant electrotechnical regulations and the accident prevention regulations that apply in the country of use. EN 60079-14 applies in Europe.

⚠ WARNING

Incorrect electrical connection will render the explosion protection unsafe.

- Only operate the device with an intrinsically safe power supply while observing the maximum parameters for electrical connection specified in the explosion protection certificate.
- Adhere to the terminal assignment.
- Do not undo the enameled screws.

ⓘ NOTICE

Risk of damage to the differential pressure meter due to the maximum permissible values specified in the EC type examination certificate being exceeded.

Do not exceed the maximum permissible values (U_i or U_0 , I_i or I_0 , P_i or P_0 , C_i or C_0 and L_i or L_0) when interconnecting intrinsically safe electrical equipment.

Otherwise, the device is no longer protected against reverse polarity.

Selecting cables and wires

- Observe the relevant clauses of EN 60079-14 for installation of intrinsically safe circuits.
- Use cable glands with M16x1.5 thread whose diameter and shape have been approved by the manufacturer for the cable used.
- Seal cable entries left unused with plugs.
- The cable entry used must correspond with the ambient temperature range and have the specified IP rating (see technical data in section 3.6).

5.4.1 Cable glands and terminals

The housing of the Media 7 Differential Pressure Meter has five threaded boreholes, which can be fitted with cable glands as required.

- The cable gland version depends on the ambient temperature range. See technical data in section 3.6 on page 24.
- The cage clamp terminals hold wire cross-sections of 0.2 to 2.5 mm².

5.4.2 Connecting the wiring

- Connect the wiring as shown in Fig. 7.
- Insert the wire without force.
- To remove the wire, use a slotted screwdriver to press the unlocking slot of the cage clamp terminal and remove the wire.
- Route the grounding connection (PE) to the corresponding terminal.

NOTICE

Risk of malfunction due to incorrect power line frequency setting.

The local power line frequency must be entered to be able to properly filter out any disturbances which are transmitted over ground wires or external power supply units.

The power line frequency (50/60 Hz) is entered in menu item 1.10 (see page 74).

The procedure to enter or change the parameters is described in section 7 on page 52 onwards.

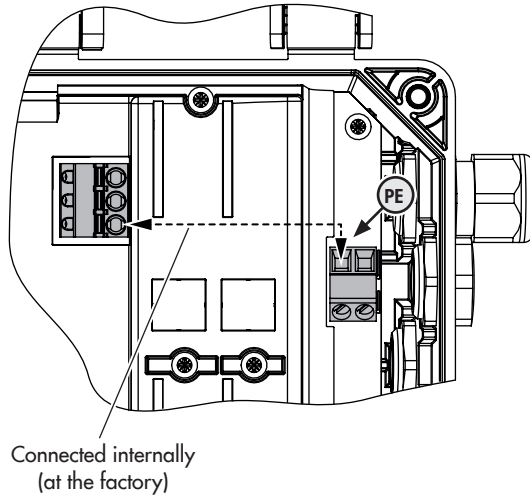

24 V version:

Electrical power



Two-wire version:

Two-wire output signal

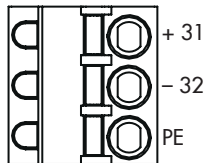

Fig. 7: Terminal assignment

6 Optional additional function

The modular design of the Media 7 device allows it to be adapted to specific requirements. Additional functions are available through the use of option modules (see section 6.1). A GSM module is also available for the 24 V version of the Media 7 device (see section 6.2).

The GSM module establishes connection to the SAM TANK MANAGEMENT web interface over a mobile network (see section 8.3).

When the Media 7 Differential Pressure Meter is ordered with additional option modules or the GSM module, they are already installed upon delivery.

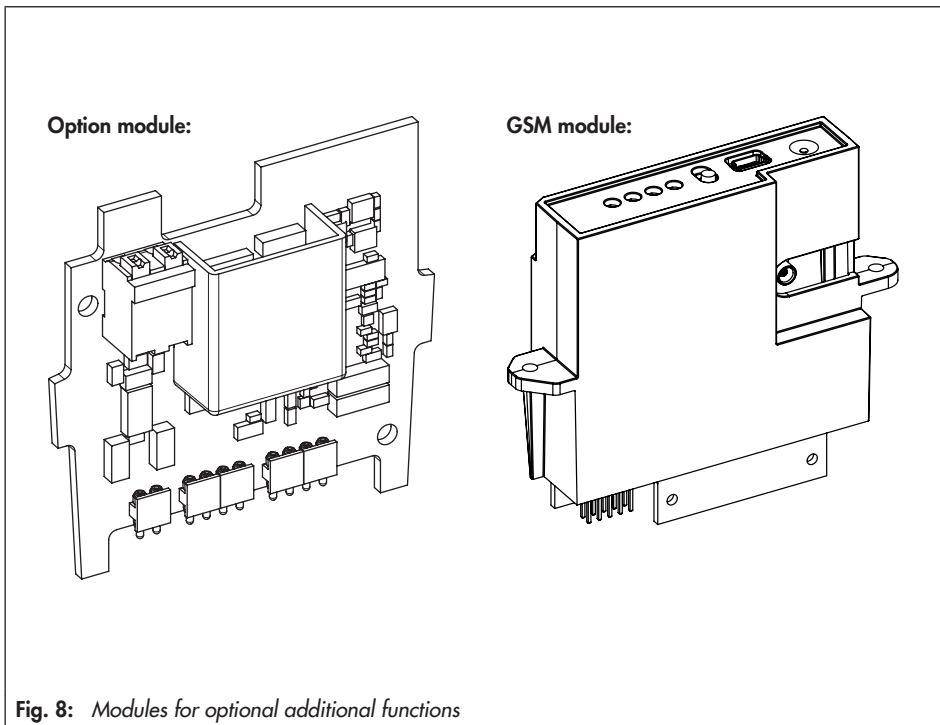

Fig. 8: Modules for optional additional functions

6.1 Option modules

Additional functions are available for the Media 7 Differential Pressure Meter, which can be added to the device by using option modules (see Fig. 8, left):

– AO: Analog output

The **Analog output** option module issues an internal measuring signal (4 to 20 mA) representing the tank pressure or, depending on the operating mode, the filling level or differential pressure. The analog output parameters can be configured.

– AI: Analog input

The **Analog input** option module accepts signals from filling level or pressure sensors of external equipment with their own power supply.

This module works passively and has galvanically isolated inputs.

– AIA: Analog input active

The **Analog input active** option module accepts signals from filling level or pressure sensors of external equipment.

This module works actively and has a 12 V output to power external equipment that do not have their own power supply.

i Note

The AO: Analog input option module is available with explosion protection.

6.1.1 Nameplate

The following nameplates are used to identify the option modules:

Option module with explosion protection (AO: Analog output only):

SAMSON 5007-1
1
2
Module 4
5
Serial no. 6

Option module without explosion protection:

SAMSON 5007 Option module 3
1

- 1 Optional additional function
- 2 Signal range
- 3 Abbreviation of optional additional function
- 4 Ordering number
- 5 Type of protection for explosion-protected devices
- 6 Serial number

6.1.2 Slots for option modules

Four slots to hold option modules exist in the Media 7 device (see Fig. 9).

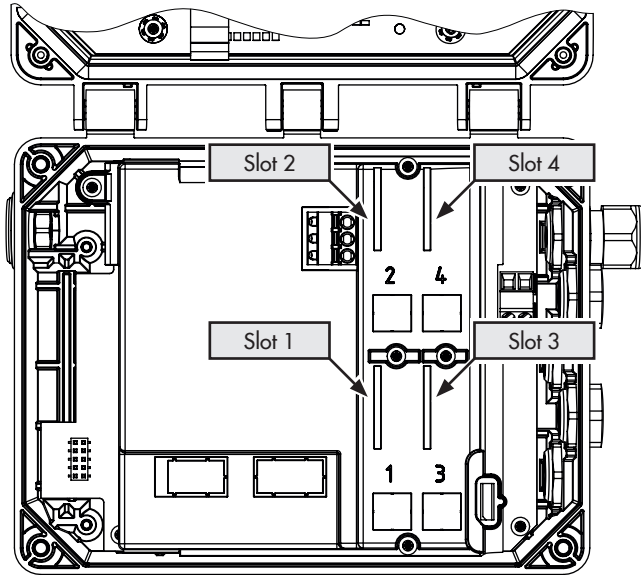

Fig. 9: Slots for option modules

NOTICE

Risk of malfunction due to the incorrect combinations of the AO: Analog output option modules

Refer to Table 6 when two option modules (AO: Analog output) are used.

Table 6: *Permissible combinations of the AO: Analog output option modules*

Option modules inserted	Permissible	Not permissible
Slot 1 and slot 2	•	
Slot 3 and slot 4	•	
Slot 1 and slot 4	•	
Slot 2 and slot 3	•	
Slot 1 and slot 3		•
Slot 2 and slot 4		•

6.1.3 Inserting or removing option modules

NOTICE

Incorrect installation or removal of the option modules will damage the differential pressure meter.

Before inserting or removing the option modules, disconnect the power supply.

NOTICE

Electrostatic discharge will damage the option modules.

– Observe the ESD requirements according to IEC 61340-5-1.

– Only store option modules in their original packaging.

Inserting the option module

→ See Fig. 11

1. Disconnect the signal lines for the power supply.
2. Undo the five screws on the cover and remove the cover.
3. Insert the option module in one of the slots, making sure it is inserted correctly.
→ Refer to Table 6 when an AO: Analog output option module is used.
4. If necessary, break open the openings for the terminals in the cover (by pressing the predetermined breaking points).
5. Place on the cover making sure that the option module is seated in the opening intended for it in the cover.
6. Fasten the cover.

7. Connect the wiring of the option module as shown in Fig. 10.
8. Connect the power supply of the differential pressure meter.

Removing the option module

1. Disconnect the signal lines for the power supply.
2. Disconnect the connecting lines on the option module.
3. Undo the five screws on the cover and remove the cover.
4. Pull the option module out of the slot and store it in its packaging.
5. Place on the cover and fasten it.
6. Connect the power supply of the differential pressure meter.

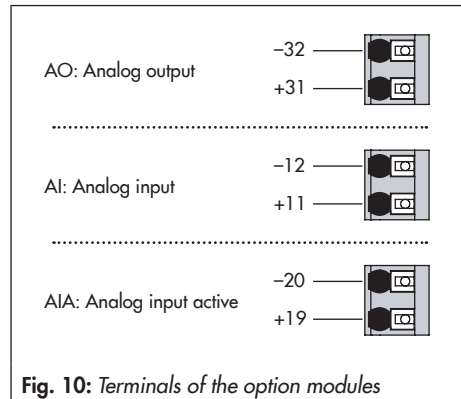

Fig. 10: Terminals of the option modules

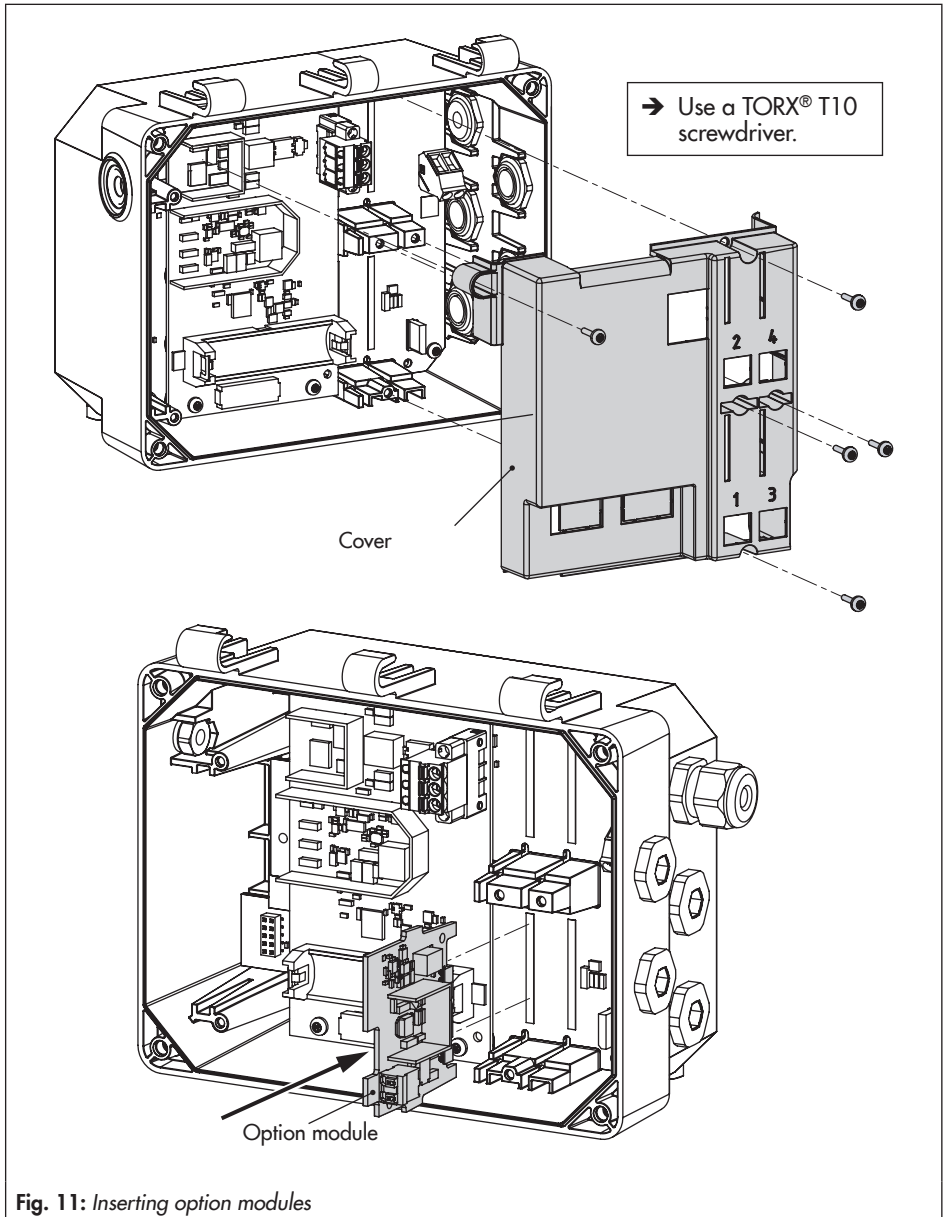

Fig. 11: Inserting option modules

6.2 GSM module

A GSM module is available for the 24 V version of the Media 7 device. The GSM module (see Fig. 8, right) establishes connection to the SAM TANK MANAGEMENT web interface over a mobile network (see section 8.3). It ensures a secure data exchange, polling of states as well as monitoring and operation of the Media 7 (see Fig. 12).

When the Media 7 Differential Pressure Meter is ordered with the GSM module, it is already installed upon delivery. The GSM module can also be retrofitted (see section 6.2.2).

i Note

The GSM module does not function when the differential pressure meter is operated with the standby power supply (SPS). See section 6.3.

6.2.1 Nameplate

The following nameplate is used to identify the GSM module:

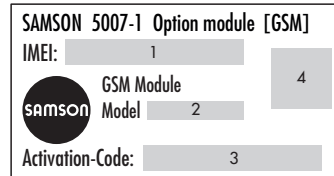

- 1 International Mobile Equipment Identity ¹⁾
- 2 Model number
- 3 Activation code
- 4 QR code

¹⁾ 15-digit serial number for unique identification of mobile devices

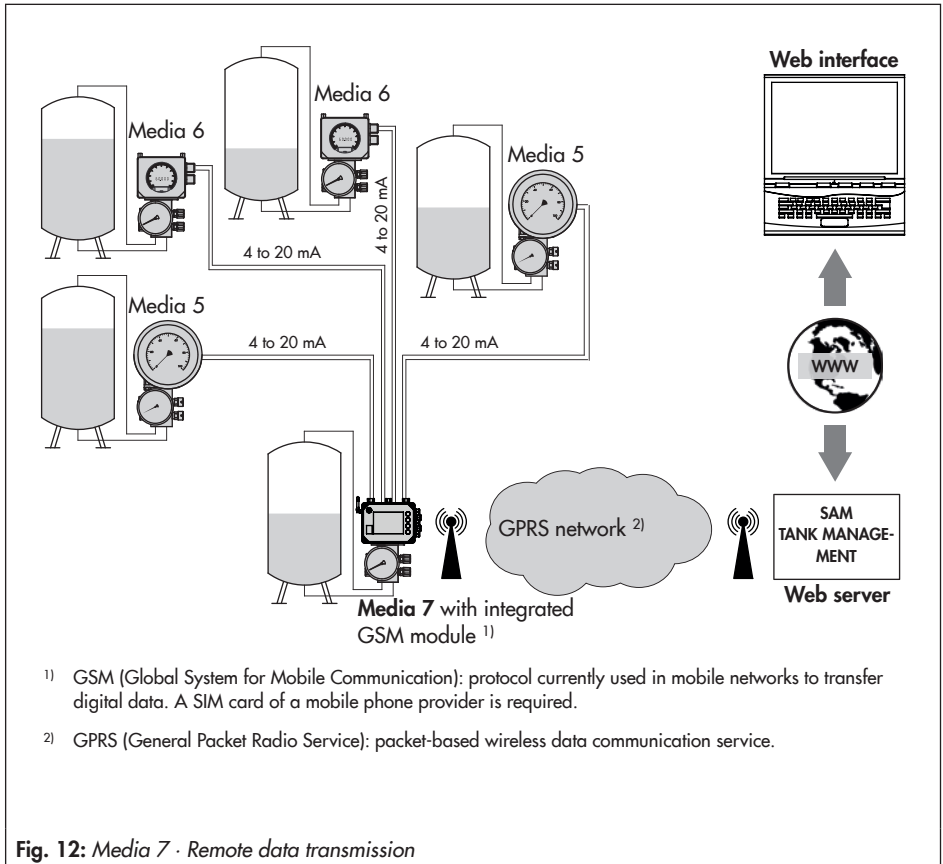

6.2.2 Installing the GSM module

The GSM module unit consists of the module (including SIM card) and the right-angle antenna with cable and SMA bushing.

NOTICE

Incorrect installation and removal of GSM module will damage the differential pressure meter.

Before inserting or removing the GSM module, disconnect the power supply.

NOTICE

Electrostatic discharge will damage the GSM module and SIM card.

– *Observe the ESD requirements according to IEC 61340-5-1.*

– *Store the GSM module and SIM card in their packaging.*

NOTICE

Incorrect installation and removal of SIM card will damage it.

Before inserting or removing the SIM card, disconnect the power supply.

Mounting the cable and antenna

1. Disconnect the signal lines for the power supply.
2. Remove the stopper in the housing (1).
3. Place the O-ring (5) on the SMA bushing and push it into the groove intended for it.
4. Guide the SMA bushing (6) with O-ring (5) from inside through the hole in the housing (1) and push it as far as it will go.
5. Place the toothed lock washer (4) on the SMA bushing (6).
6. Place the nut (3) on the SMA bushing (6) and screw tight.
7. Screw the antenna (2) onto the SMA bushing.

Inserting the module

8. Insert the male connector (7) into the female connector (8) on the module.
9. Insert the module into the slot as shown in the diagram.
10. Tighten the two fastening screws (9) of the module.
11. Connect the power supply of the differential pressure meter.

Note

How to establish connection to the web interface is described in section 8.3.

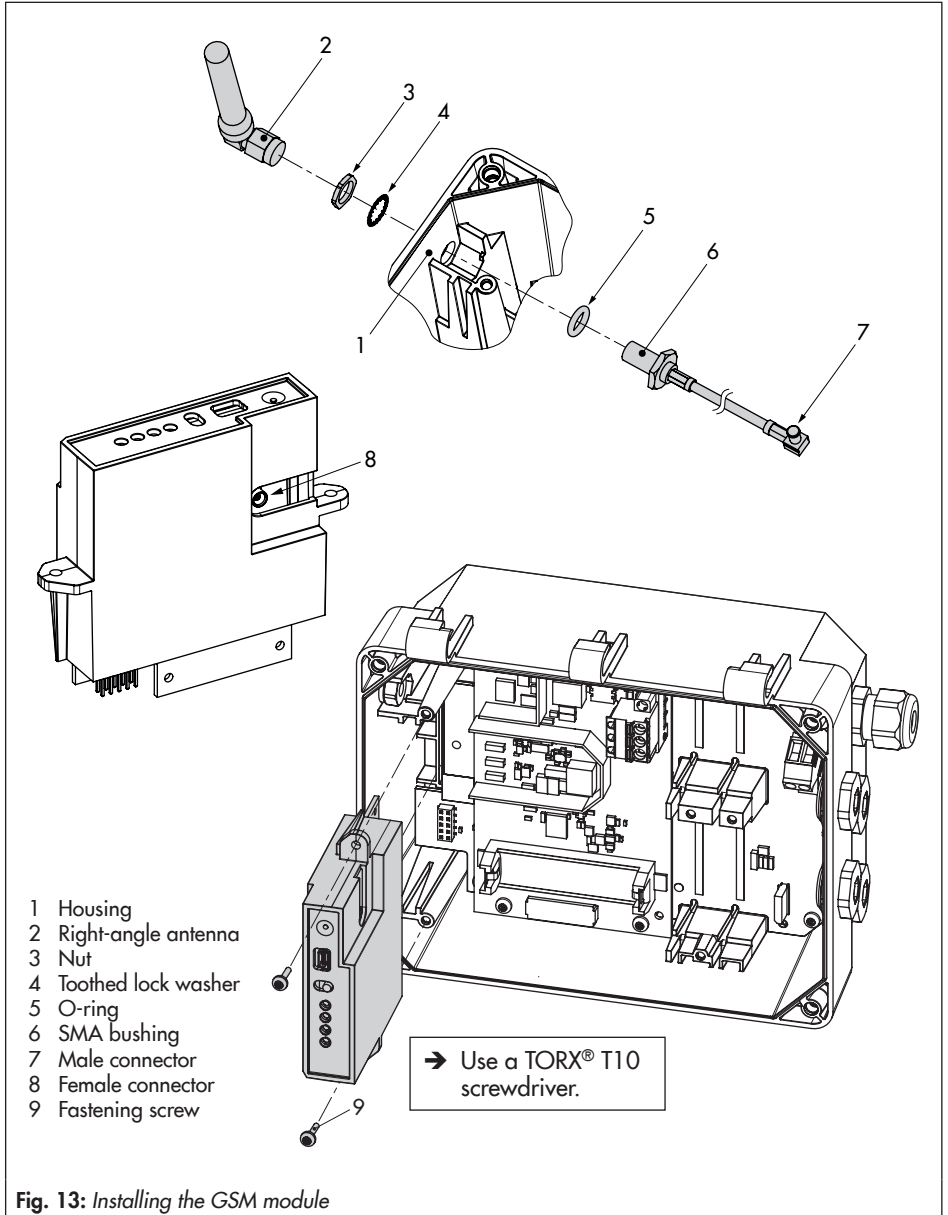

Fig. 13: Installing the GSM module

6.2.3 Aligning the antenna

Move the antenna to the upright position for the best reception results. If a weather guard or other housing parts are located directly above the device due to the mounting situation, tilt the antenna slightly.

→ Refer to Fig. 14.

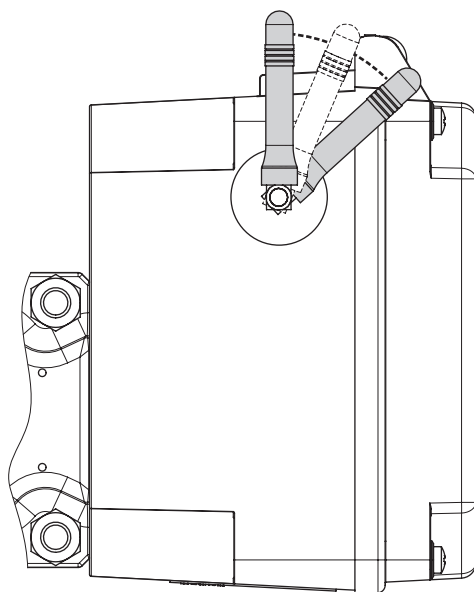

Fig. 14: *Aligning the antenna*

6.3 Standby power supply (SPS)

To continue to supply the power supply unit with power after a power failure, we recommend using a battery with the following specifications:

- AA lithium battery (mignon), 1.5 V
- Industrial battery with long service life (min. 3000 mAh recommended)
- Suitable for temperatures from -40 to +60 °C

NOTICE

The use of unapproved batteries will damage the differential pressure meter.

Do not use rechargeable batteries in the differential pressure meter.

Note

The battery is not included in the scope of delivery.

Operation with standby power supply (SPS) is restricted as follows:

- The **GSM module** does not function in SPS mode.
 - The **AIA: Analog input active option module** does not supply any voltage.
-

Tip

The standby power supply can also be used during the first start-up when no other power supply is available. A lithium battery allows the device to run for approx. seven days.

6.3.1 Inserting the battery

ⓘ NOTICE

Incorrect installation or removal of the 1.5 V battery will damage the differential pressure meter.

Before inserting or removing the 1.5 V battery, disconnect the power supply.

→ See Fig. 15

1. Disconnect the signal lines for the power supply.
2. Undo the five screws on the cover and remove the cover.
3. Place the 1.5 V battery in the battery compartment.

→ **Observe the correct polarity.** A battery symbol with plus and minus signs on the battery compartment indicates the polarity.

4. Place on the cover and fasten it.
5. Connect the power supply of the differential pressure meter.

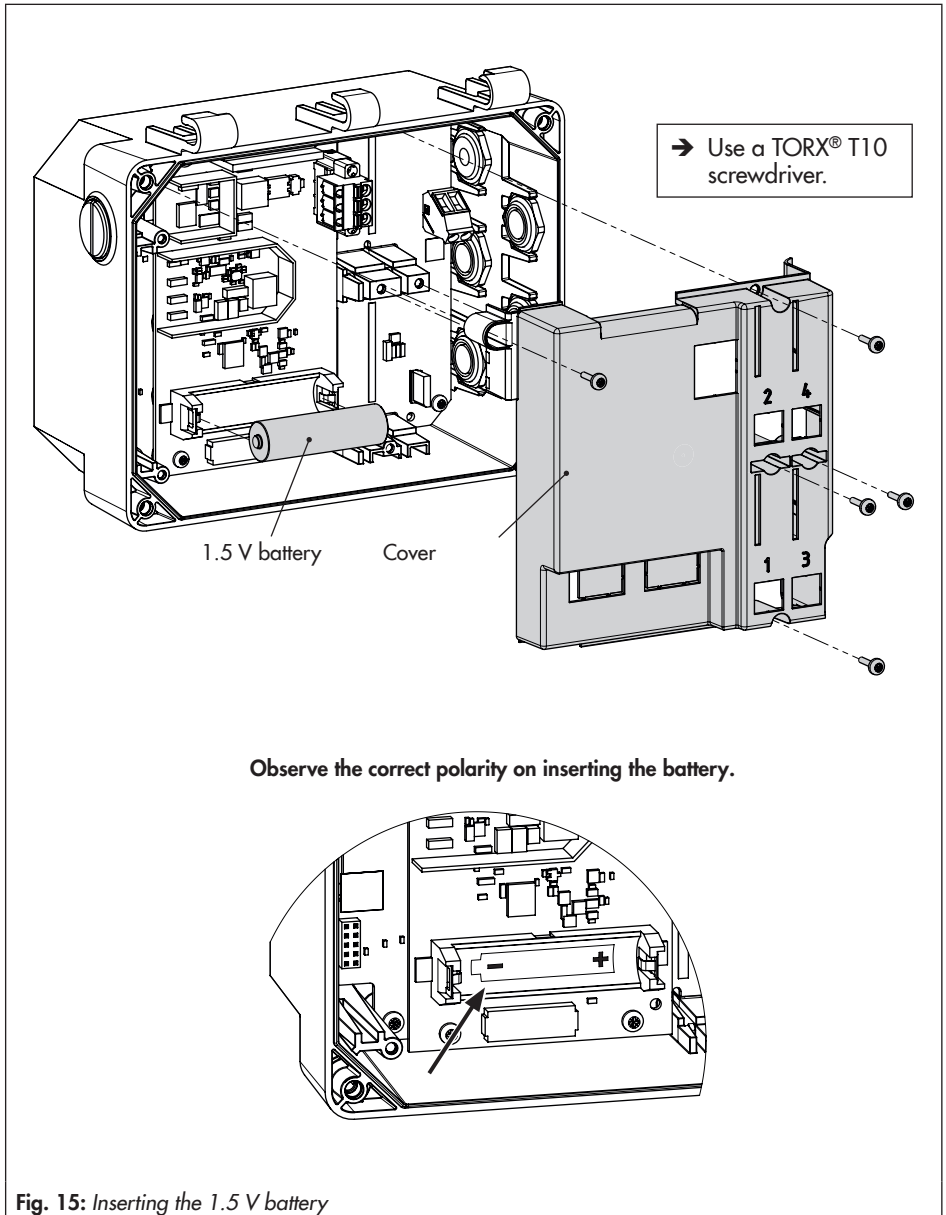

7 Operation

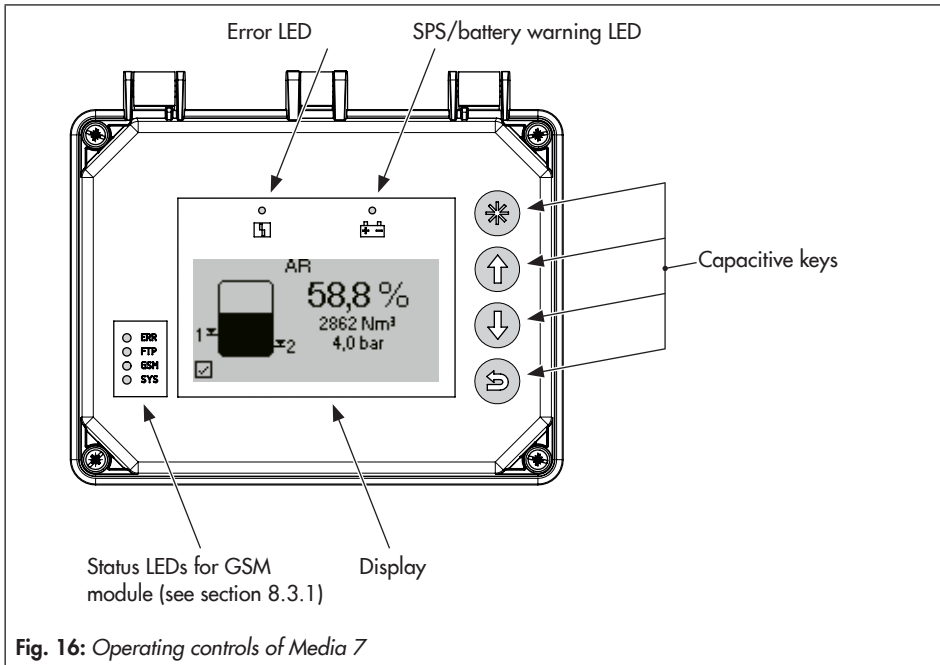





Tip

Examples for the operation of the Media 7 device are described in section 7.3.

7.1 Capacitive keys

The capacitive keys for on-site operation are located to the right of the display.

-  Confirm, select, change
-  Scroll upward, increase value
-  Scroll downward, reduce value
-  Back

7.2 Display

After connection of the power supply for the first time, the **start-up wizard** automatically starts (see section 8.1.1). In all other cases, the **start screen** (see Fig. 17) appears. Press the  key to go to the main menu. Settings can be made and process values read in the main menu.

Section 8.1 contains a description of the first start-up settings. A list of parameters for on-site operation is included in the Annex (section 12.2 on page 73 onwards).

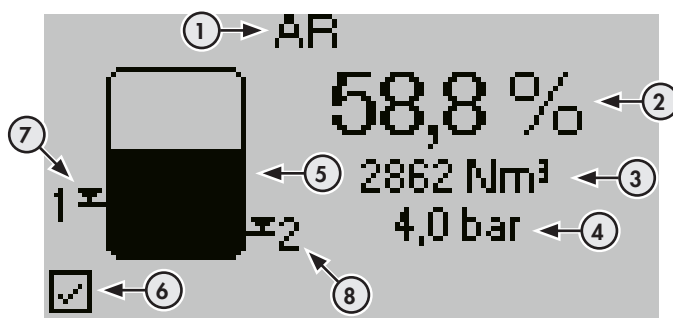

- 1 Process medium selected
- 2 Filling level in %
- 3 Liquid level reading in the selected unit
- 4 Tank pressure in the selected unit
- 5 Animated filling level with filling limits 1 and 2 (see page 85)
- 6 Device status (see Table 7 on page 69)
- 7 Filling level pre-alarm
- 8 Filling level main alarm

Fig. 17: Start screen of Media 7 (filling level mode in the example shown)

7.3 Examples for the operation of the Media 7 device

Note

The Media 7 device has two user levels with different access privileges: **Maintenance staff** and **Specialist**.

Values and parameters can only be changed in the **Specialist** user level. See section 8.1.3 for more information on the user level and maximum password protection.











If no settings are entered within five minutes, the display returns to the start screen and the user level returns to **Maintenance staff**.

Tip











The instructions below apply to the general navigation through the menus of the Media 7 device and to changing the parameters.

➔ Description of the operating controls on page 52.











Example 1: changing the language

1. Press  key (in start screen) to go to the main menu.
2. Select Start-up (1) with  or  key and confirm with  key.
3. Select User level (1.1) with  or  key and confirm with  key.
4. Press  key and select 'Specialist' with  or  key.
5. Press  key to confirm the setting.
▶ It is now possible to change parameters in the Media 7 device.

















Changing the language:

1. Press  key (in start screen) to go to the main menu.
2. Select Start-up (1) with  or  key and confirm with  key.
3. Select Sprache/Language (1.2) with  or  key and confirm with  key.
4. Press  key and select the required language with  or  key.
5. Press  key to confirm the setting.
▶ The language has been changed.











Example 2: changing the medium in the filling level mode

1. Press  key (in start screen) to go to the main menu.
 2. Select Start-up (1) with  or  key and confirm with  key.
 3. Select User level (1.1) with  or  key and confirm with  key.
 4. Press  key and select 'Specialist' with  or  key.
 5. Press  key to confirm the setting.
- ▶▶ It is now possible to change parameters in the Media 7 device.







Changing the medium (in the filling level mode only):

1. Press  key (in start screen) to go to the main menu.
 2. Select Device settings (2) with  or  key and confirm with  key.
 3. Select Filling level mode (2.2) with  or  key and confirm with  key.
 4. Select Medium (2.2.2) with  or  key and confirm with  key.
 5. Select Medium selection (2.2.2.1) with  or  key and confirm with  key.
 6. Press  key and select the required medium with  or  key.
 7. Press  key to confirm the setting.
- ▶▶ The medium has been changed.











Example 3: changing the unit (medium) in the filling level mode

1. Press  key (in start screen) to go to the main menu.
 2. Select Start-up (1) with  or  key and confirm with  key.
 3. Select User level (1.1) with  or  key and confirm with  key.
 4. Press  key and select 'Specialist' with  or  key.
 5. Press  key to confirm the setting.
- ▶▶ It is now possible to change parameters in the Media 7 device.











Changing the unit (medium) in the filling level mode:

1. Press  key (in start screen) to go to the main menu.
2. Select Device settings (2) with  or  key and confirm with  key.
3. Select Filling level mode (2.2) with  or  key and confirm with  key.















Operation

4. Select Medium (2.2.2) with  or  key and confirm with  key.
5. Select Unit (2.2.2.2) with  or  key and confirm with  key.
6. Press  key and select the required unit with  or  key.
7. Press  key to confirm the setting.
 - ▶▶ The unit has been changed.

Example 4: changing the unit of pressure sensor











1. Press  key (in start screen) to go to the main menu.
2. Select Start-up (1) with  or  key and confirm with  key.
3. Select User level (1.1) with  or  key and confirm with  key.
4. Press  key and select 'Specialist' with  or  key.
5. Press  key to confirm the setting.
 - ▶▶ It is now possible to change parameters in the Media 7 device.

Changing the unit (pressure sensor) in the filling level mode/differential pressure mode:





















1. Press  key (in start screen) to go to the main menu.
2. Select Device settings (2) with  or  key and confirm with  key.
3. Select General (2.1) with  or  key and confirm with  key.
4. Select Pressure sensor (2.1.5) with  or  key and confirm with  key.
5. Press  key and select the required unit with  or  key.
6. Press  key to confirm the setting.
 - ▶▶ The unit has been changed.

Example 5: changing the medium identifier

The medium identifier is the user-defined name of the medium. A maximum of 15 characters can be used. The default setting for this parameter is 'MEDIA7'.

1. Press  key (in start screen) to go to the main menu.
 2. Select Start-up (1) with  or  key and confirm with  key.
 3. Select User level (1.1) with  or  key and confirm with  key.
 4. Press  key and select 'Specialist' with  or  key.
 5. Press  key to confirm the setting.
- ▶▶ It is now possible to change parameters in the Media 7 device.

Changing the medium identifier:

1. Press  key (in start screen) to go to the main menu.
 2. Select Device settings (2) with  or  key and confirm with  key.
 3. Select General (2.1) with  or  key and confirm with  key.
 4. Select Identifier (2.1.1) with  or  key and confirm with  key.
- ▶▶ The identifier currently used is shown.
5. Press the  key. The cursor jumps to the first of maximum 15 characters.
 6. Move the cursor to the position you want to change with  or  key and activate it with  key.
Select a letter, number or special character with  or  key from the listed characters and confirm with  key.
- ▶▶ The cursor automatically jumps to the next position on the right.
7. Continue as described in step 6 to enter further characters (max. 15 characters can be selected).
 8. Press  key after you have completed entering the identifier.
 9. Select OK with  or  key and confirm with  key.
- ▶▶ The medium identifier has been changed.

8 Operation of Media 7 Differential Pressure Meter

Once the mounting and start-up activities have been completed, you can start with the settings. The differential pressure meter is ready for use immediately after the electrical power supply has been connected.

8.1 First start-up

After the differential pressure meter is put into operation for the first time after shipment, the wizard starts automatically after the electrical power is connected.



Tip

We recommend proceeding as follows during first start-up:

1. Run the start-up wizard (see section 8.1.1).
2. Set user level (see section 8.1.3).
3. Perform zero calibration (see section 8.1.4).





8.1.1 Running the start-up wizard







Note

- The language is set to English by default on first start-up.
- If no settings are entered within five minutes, the display returns to the start screen.



Step 1 of 6: select language





1. Select the required language with  or  key.
2. Confirm the selected language with  key. Press  key again to continue.

Step 2 of 6: select unit









1. Select the required unit with  or  key.
2. Confirm the selected unit with  key. Press  key again to continue.

Step 3 of 6: set the minimum differential pressure Δp_0









1. Select the required digit within the number with  or  key. Press  key to confirm the selected digit.

2. Select the required number with  or  key. Press  key to confirm the changed number.
3. After selecting all digits of the number, press  key.
4. Press  key to continue.

Step 4 of 6: set the maximum differential pressure Δp_{100}

1. Select the required digit within the number with  or  key. Press  key to confirm the selected digit.
2. Select the required number with  or  key. Press  key to confirm the changed number.
3. After selecting all digits of the number, press  key.
4. Press  key to continue.

Step 5 of 6: enter the medium code

1. Press  key to enter the first character.
2. Select the required character with  or  key. Press  key to confirm the selected character.
3. Proceed in the same way to enter the other characters of the medium code.
4. Press  key.
5. Select OK with  or  key and confirm with  key.
6. Press  key again to continue.

Step 6 of 6: complete start-up wizard

- Press  key (Done) to close the wizard.
The display returns to the start screen.



Note

- Select **ESC** to exit the wizard at any time.
- Select **forward** (>) and **back** (<) to navigate between steps 1 and 6.
- The wizard can be started at any time in the start-up (1) menu by selecting menu item 1.4 ('Specialist' user level only).

8.1.2 Option module wizard

If option modules are installed, the option module wizard automatically starts during first start-up after completion or exiting the start-up wizard.

After the option module wizard starts, the slots for option modules are shown.

1. Press  or  key to select the required slot or option module.
2. Press  key to confirm the setting.
 - ▶ Depending on the selected option module, diverse settings, such as name, signal source, limit etc., can be made. Descriptions to the parameters can be found in the parameter list (section 12.2) for the corresponding option modules from menu item 2.4 onwards.











Note

- Select **ESC** to exit the option module wizard at any time.
 - Select **forward** (>) and **back** (<) to navigate between steps.
 - The option module wizard can be started from the Device settings (2) menu/Option modules (2.4)/Overview of option modules (2.4.1 and 2.4.1.1) by selecting a slot/option module ('Specialist' user level only).
 - If no settings are entered within five minutes, the display returns to the start screen.
-

8.1.3 Setting the user level



















The Media 7 device has two user levels with different access privileges:

- **Maintenance staff:** values and parameters can be selected and read in this user level. Changes are not possible in this level.
- **Specialist:** all values can be accessed and parameters changed in this user level. This user level can be password-protected to prevent unauthorized access.

1. Press  key (in start screen) to go to the main menu.
2. Select Start-up (1) with  or  key and confirm with  key.
3. Select User level (1.1) with  or  key and confirm with  key.
4. Press  key and select 'Specialist' with  or  key.
5. Press  key to confirm the setting.

Activating password protection

The password can only be changed and activated in the Specialist user level.

1. Press  key (in start screen) to go to the main menu.
2. Select Start-up (1) with  or  key and confirm with  key.
3. Select Password protection (1.7) with  or  key.
4. Press  key to activate password protection.
 → The default password is **1234**. To change the password, proceed as follows:
 1. In the Start-up (1) menu, select Password (1.8) with  or  key and confirm with  key.
 2. Press  key. Select the digit within the password with  or  key.
 3. Press  key. Change the number (0 to 9) within the password with  or  key.
 4. Confirm with  key (proceed in the same way for the rest of the password).
 5. After selecting all digits of the password, press  key.

8.1.4 Performing zero calibration

We recommend performing a zero calibration after first start-up and after changes have been made to the plant.

To set zero, the pressure in the measuring lines must be equal. To check zero, make sure that the pressures in both measuring chambers are identical at atmospheric pressure, i.e. the signal at the terminals 31 and 32 must be 4 mA at a differential pressure of $\Delta p = 0$ mbar (see Fig. 7 on page 37).

At $\Delta p = 0$ mbar, the 0.0 % reading must be displayed.









i Note

The user level must be set to 'Specialist' for the zero calibration (see section 8.1.3).

i Note

When gas column correction is selected, you need to take into account that the gas columns in the measuring lines reduce the differential pressure because they oppose each other. When the pressures are identical ($\Delta p = 0$ mbar) a negative value appears on the display for the content. An output signal lower than 4 mA is indicated. In this case, readjust zero as described below so that the display reads 0 % at $\Delta p = 0$ mbar. The output signal will change but remains below 4 mA due to the adjusted gas column correction.

Zero calibration when the tank is empty

1. Press  key (in start screen) to go to the main menu.
2. Select Start-up (1) with  or  key and confirm with  key.
3. Select Zero (1.5) with  or  key and confirm with  key.
 - ▶ The current values for differential pressure, zero, and maximum differential pressure (Δp_{100}) are displayed.
4. Press  key to set zero.

Zero calibration when the tank is filled

➔ To equalize the pressures, isolate the measuring lines to the tank and connect them over a bypass. When a SAMSON valve block is used, proceed as follows (see Fig. 5 on page 23):

1. Close shut-off valve (+) and shut-off valve (-).
2. Open the equalizing valve.
 - ➔ The valve block is now in the test position.
3. Perform zero calibration (see Zero calibration when the tank is empty).
- ➔ Place the valve block or equalizing valve back into the operating position:
4. Open the shut-off valve in the low-pressure line.
5. Close the equalizing valve.
6. Open the shut-off valve in the high-pressure line.

8.2 Calibrating the measuring range (span)

NOTICE

Impermissible conditions during measurement will damage the differential pressure meter. The test medium must be free of oil and grease when the device is used to measure oxygen. Additional conditions include:

- Gaseous oxygen (process medium)
- Temperature: max. +60 °C
- Oxygen pressure: max. 30 bar

When the device is used for oxygen service, make sure that the dp cell and any SAMSON accessories only come into contact with gaseous oxygen.

Upon delivery, the device is calibrated with a linear characteristic based on the upper measuring range value of the dp cell. After entering the tank and gas data, the device automatically adopts the tank characteristic. Based on the gas data for the activated gas type, the device calculates the readings and output signal (4 to 20 mA) proportional to the tank content. In the same way, the device calculates the max. possible differential pressure Δp_{100} in mbar for the gas type and the predefined reference height (total height or gauge pipe).

How to proceed:

Note

The user level must be set to 'Specialist' for the measuring range calibration (see section 8.1.3).

- Observe the sequence:
 1. Calibrate zero.
 2. Calibrate the measuring range (span).
- At Δp_{100} , the output signal must be 20 mA.
- To check the measuring range, connect the differential pressure meter as shown in Fig. 18.



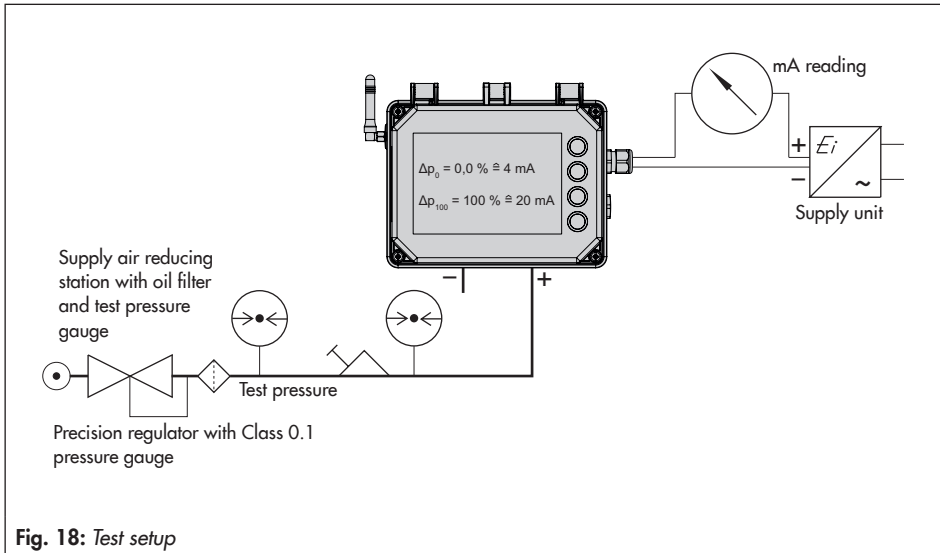





Operation of Media 7 Differential Pressure Meter



Checking the measuring range (span)

1. Press \odot key (in start screen) to go to the main menu.
2. Select Start-up (1) with \uparrow or \downarrow key and confirm with \odot key.
3. Select Span (1.6) with \uparrow or \downarrow key and confirm with \odot key.
 - ▶ The current values for differential pressure, span and maximum differential pressure (Δp_{100}) are displayed.
4. Use a precision regulator to apply a test pressure corresponding to the max. differential pressure Δp_{100} while monitoring the pressure gauge.
 - ➔ Set points: $\Delta p = 0 \text{ mbar}$ or 4 mA (read note on gas column correction)
 - ➔ When the reading and output signal do not match the indicated Δp_{100} value, readjust the upper range value (span).

Adjusting the measuring range (span)

1. Press  key (in start screen) to go to the main menu.
2. Select Start-up (1) with  or  key and confirm with  key.
3. Select Span (1.6) with  or  key and confirm with  key.
4. Press  key to set the span.

8.3 Remote data transmission

i Note

The remote data transmission can only be used when a GSM module is installed.

To use remote data transmission, SAMSON creates a user account for each customer in the SAM TANK MANAGEMENT web interface. All devices are added to the account by SAMSON.

→ Contact SAMSON's After-sales Service department for more information on how to register in SAM TANK MANAGEMENT.

8.3.1 Status LEDs of the GSM module

The table below describes the meaning of the LEDs (see Fig. 16):

LED	Color	Illuminated	Blinks
ERR	Red	Error or failure	2x: GSM module without SIM card 3x: incorrect PIN
FTP	Green		Fast blinking: data transmission in progress
GSM	Green	Searching for a network	1x: GSM connection OK 2x: server connection OK 3x: PIN code failed 4x: hardware error Fast blinking: incoming SMS text message
SYS	Green		1x: system ON

9 Servicing

i Note

The differential pressure meter was checked by SAMSON before it left the factory.

- *The product warranty becomes void if service or repair work not described in these instructions is performed without prior agreement by SAMSON's after-sales service.*
- *Only use original spare parts by SAMSON, which comply with the original specifications.*

9.1 Servicing explosion-protected devices

If a part of the device on which the explosion protection is based needs to be serviced, the device must not be put back into operation until a qualified inspector has assessed it according to explosion protection requirements, has issued an inspection certificate, or given the device a mark of conformity. Inspection by a qualified inspector is not required if the manufacturer performs a routine test on the device before putting it back into operation. Document the passing of the routine test by attaching a mark of conformity to the device.

- Retain testing and servicing documents as well as certificates issued by the manufacturer or inspector together with other safety-relevant documents for the device or plant.

Replace explosion-protected components only with original, routine-tested components by the manufacturer. Specify the type and serial number on ordering the device.

Devices that have already been operated outside hazardous areas and are intended for future use inside hazardous areas must comply with the safety requirements placed on serviced devices. Before being operated inside hazardous areas, test the devices according to the specifications for servicing explosion-protected devices.

Devices delivered without an intrinsically safe power supply unit must not be put back into operation in hazardous areas until a qualified inspector or manufacturer has tested it.

Maintenance, calibration and work on equipment

- Interconnection with intrinsically safe circuits to check or calibrate the equipment inside or outside hazardous areas is to be performed only with intrinsically safe current/voltage calibrators and measuring instruments to rule out any damage to components relevant to explosion protection.
- Observe the maximum permissible values specified in the certificates for intrinsically safe circuits.

9.2 Preparation for return shipment

Defective differential pressure meters can be returned to SAMSON for repair.

Proceed as follows to return devices to SAMSON:

1. Decontaminate the differential pressure meter. Remove any residual process medium.
2. Fill in the Declaration on Contamination. The declaration form can be downloaded from our website at www.samsongroup.com > *Service & Support* > *After-sales Service*.
3. Remove differential pressure meter (see section 11).
4. Send the differential pressure meter to your nearest SAMSON subsidiary. SAMSON subsidiaries are listed on our website at www.samsongroup.com (*About SAMSON > Sales offices*).

9.3 Firmware update

Contact your local SAMSON engineering and sales office or subsidiary to request a firmware update. SAMSON subsidiaries are listed on our website at

▶ www.samsongroup.com (*About SAMSON > Sales offices*).

Required specifications





Please submit the following details on requesting a firmware update:

- Type
- Serial number
- Configuration ID
- Current firmware version
- Required firmware version

10 Malfunctions

Malfunctions are indicated on the display by error messages in conjunction with an icon for status classification and an error ID. The meaning of the icons and their order of priority are listed in Table 7.

Table 7: Icon showing status classification

Status icon	Priority	Meaning
	1	Failure
	2	Out of specification
	3	Maintenance required
	4	No message

On the start screen, error messages can be cleared by pressing the  key. Error messages and recommended action for troubleshooting are listed in Table 8.

Table 8: Troubleshooting

Error ID	Message	Possible causes and recommended action
101	AMR magnet lost	The Media 7 device has an internal device error. → Contact SAMSON's After-sales Service.
102	AMR sensor not recognized	
103	Memory error (calibration)	
104	Memory error (data)	
105	No factory calibration	
106	Pressure sensor error	
107	Internal data processing error	
201	AMR signal outside range	→ Reset the Media 7 device. Contact SAMSON's After-sales Service when this error reoccurs.
202	Measuring span error	→ Check the settings for the tank and media data. Correct them, if necessary.
203	Characteristic error	An invalid tank geometry has been entered: → Re-enter tank data (only possible in TROVIS-VIEW).

Malfunctions

Error ID	Message	Possible causes and recommended action
204	AMR temperature sensor	The temperature sensor has failed. → Reset error message. Contact SAMSON's After-sales Service when this error reoccurs.
205	Temperature inside device below min. limit	The temperature limit inside the device has fallen below the adjusted min. limit. → Check whether the heating functions properly and the heating control is switched on. → Select lower temperature limit.
206	Temperature inside device above max. limit	The temperature limit inside the device has exceeded the adjusted max. limit. → Check whether the heating functions properly and the heating control is switched on. → Select a better location to mount the Media 7 device, if necessary.
207	Large differential pressure drop	The bypass valve has been opened. A diaphragm rupture in the dp cell exists. The dp cell leaks. → Check all screw fittings.
301	Power supply unit not recognized	The current firmware of the device does not support the supply voltage. A firmware update is necessary. → Contact SAMSON's After-sales Service.
302	Option not recognized	The current firmware of the device does not support the option. A firmware update is necessary. The option is defective. → Contact SAMSON's After-sales Service.
303	Option module combination invalid	Option modules are inserted incorrectly or the incorrect combination of modules has been used. → Check the combination and how the option modules are inserted.

11 Decommissioning and removal

11.1 Decommissioning

To decommission the differential pressure meter before removing it, proceed as follows:

1. Isolate measuring lines.
- When a valve block is used:
 2. Close the shut-off valves.
 3. Open the equalizing valve.
 4. Slowly open the screw of the test connection to release the pressure.
5. Disconnect the power supply.
6. Open the housing cover of the differential pressure meter and disconnect the wires for the power supply.

11.2 Removing the differential pressure meter

1. Disconnect the wires for the power supply from the differential pressure meter.
2. To remove the differential pressure meter, loosen the fastening screws on the device.

11.3 Disposal

- Do not dispose of components, lubricants and hazardous substances together with your other household waste.
- Check whether a battery is inserted in the differential pressure meter and remove it before disposing of the device.
- Observe local, national and international refuse regulations before disposing of the device and its batteries.

Note

We can provide you with a recycling passport according to PAS 1049 on request. Simply e-mail us at aftersaleservice@samsongroup.com giving details of your company address.

Tip

On request, we can appoint a service provider to dismantle and recycle the product.

12 Annex

12.1 After-sales service

Contact SAMSON's after-sales service for support concerning service or repair work or when malfunctions or defects arise.

E-mail address

You can reach our after-sales service at aftersalesservice@samsongroup.com.

Addresses of SAMSON AG and its subsidiaries

The addresses of SAMSON AG, its subsidiaries, representatives and service facilities worldwide can be found on our website (www.samsongroup.com) or in all SAMSON product catalogs.

Required specifications

Please submit the following details:

- Order number and position number in the order
- Type, serial number
- Firmware version
- Device version
- Measured medium
- Pressure, differential pressure

12.2 Menu structure and parameters

i Note

The availability of executed menu items and parameters depends on the version and configuration of the differential pressure meter as well as the option modules used. Default settings are marked 'default'.

Menu		Adjustment range/values/description
Start-up	1	
User level	1.1	Select user level <ul style="list-style-type: none"> ▪ Maintenance staff: restricted access ▪ Specialist: full access (password protection possible in menu item 1.7)
Sprache/Language	1.2	Select the menu and display language: <ul style="list-style-type: none"> ▪ German/English (default)/French/Italian/Spanish
Operating mode	1.3	Select the operating mode: <ul style="list-style-type: none"> ▪ Differential pressure (default): differential pressure measurement with linear characteristic ▪ Filling level: the device issues an mA signal (4 to 20 mA) which is proportional to the tank content.
Start-up wizard	1.4	Run the wizard.
Zero point	1.5	Set zero (resetting zero is possible)
Span	1.6	Set the span (resetting span is possible)
Password protection	1.7	The 'Specialist' user level can be protected by a four-digit code (menu item 1.8). <ul style="list-style-type: none"> ▪ Not active ▪ Active
Password	1.8	Enter a four-digit code <ul style="list-style-type: none"> ▪ 0000 to 9999
Write protection (data transmission module)	1.9	Activate write protection (data transmission module) <ul style="list-style-type: none"> ▪ Yes ▪ No

Menu		Adjustment range/values/description
Power line frequency	1.10	The local power line frequency must be entered to be able to properly filter out any disturbances which are transmitted over ground wires or external power supply units. <ul style="list-style-type: none"> ▪ 50 Hz (default) ▪ 60 Hz
Start test	1.11	Executable function: two-wire test signal issued.
Test mode	1.12	Test mode is <i>Active</i> while the test is in progress (test duration: 30 s). <ul style="list-style-type: none"> ▪ Not active ▪ Active
Test signal of analog output	1.13	Test signal in % based on the 4 to 20 mA signal range. <ul style="list-style-type: none"> ▪ -10.00 to +110.00 %
Device settings	2	
General	2.1	
Identifier	2.1.1	Enter a freely selectable code for the device (max. 15 characters) <ul style="list-style-type: none"> ▪ Enter characters as required (default: MEDIA7)
Filling level	2.1.2	The filling level in % can be displayed on the start screen. <ul style="list-style-type: none"> ▪ Yes ▪ No
Differential pressure	2.1.3	The differential pressure together with a unit can be displayed on the start screen. <ul style="list-style-type: none"> ▪ Yes ▪ No
Pressure sensor	2.1.4	The value measured by the pressure sensor together with a unit can be displayed on the start screen. <ul style="list-style-type: none"> ▪ Yes ▪ No
Unit of pressure sensor	2.1.5	Determine the unit for the value measured by the pressure sensor <ul style="list-style-type: none"> ▪ Selectable units: bar (default)/kPa/psi/cmH₂O/mH₂O/inH₂O
MCN/SCN	2.1.6	MCN (maximum tank content in %) or SCN (tank content up to overflow/gauge pipe) reading on the display. <ul style="list-style-type: none"> ▪ No (default) ▪ Yes

Menu		Adjustment range/values/description
Hazard warning for filling limit	2.1.7	Select filling limit to be indicated on the display when this limit is reached. <ul style="list-style-type: none"> ▪ SCN (volume up to gauge pipe) ▪ UCW (operating filling limit)
LCD backlight	2.1.8	The LCD backlight can be switched on or off (in 24 V version only). <ul style="list-style-type: none"> ▪ ON ▪ OFF
LCD deactivation time	2.1.9	The LCD of the Media 7 device can be switched off after the entered deactivation time (see 2.1.10, only when the OFF setting is selected). <ul style="list-style-type: none"> ▪ ON (default) ▪ OFF
Deactivation time	2.1.10	Enter the time after which the LCD of the Media 7 device is to be automatically switched off. <ul style="list-style-type: none"> ▪ 1 to 10 min (default: 10 min)
LCD heating control	2.1.11	The 'ON' setting causes the display to be heated when the outdoor temperature is low. The power consumption of the device increases by 510 mA when the heating is activated. Upper switching temperature (deactivate): $-12.5\text{ }^{\circ}\text{C}$ Lower switching temperature (activate): $-17.5\text{ }^{\circ}\text{C}$ <ul style="list-style-type: none"> ▪ ON (default) ▪ OFF
Filling level mode	2.2	
Tank	2.2.1	Perform tank data settings (menu items 2.2.1.x) in TROVIS-VIEW software, ► EB 9510-2.
Tank identifier	2.2.1.1	▪ Settings performed in TROVIS-VIEW
Tank type	2.2.1.2	▪ Settings performed in TROVIS-VIEW
Shape of tank head	2.2.1.3	▪ Settings performed in TROVIS-VIEW
Tank truck	2.2.1.4	▪ Settings performed in TROVIS-VIEW
Diameter	2.2.1.7	▪ Settings performed in TROVIS-VIEW
Length/height of tank	2.2.1.8	▪ Settings performed in TROVIS-VIEW
Length/height of measuring line	2.2.1.11	▪ Settings performed in TROVIS-VIEW
Volume at 20 mA	2.2.1.12	▪ Settings performed in TROVIS-VIEW

Menu		Adjustment range/values/description
Permissible filling limit	2.2.1.13	▪ Settings performed in TROVIS-VIEW
Medium	2.2.2	
Medium selection	2.2.2.1	Select medium (depending on the entered medium identifier)
Unit	2.2.2.2	Unit for calculating the tank content [MCN], [SCN] and [UCW] and the filling level ▪ Selectable units: % · kg · Nm ³ · L · ft ³ · lbs
Medium database	2.2.3	
Medium 1	2.2.3.1	
to	to	
Medium 8	2.2.3.8	
Medium identifier1	Enter a name (max. 11 characters) to identify the medium. ▪ Enter characters as required
Shrink factor2	Enter tank's shrink factor. This value depends on the tank material, operating temperature, and the process medium. ▪ 0.95 to 1.00
Operating filling limit3	Enter operating filling limit in % ▪ 0.00 to 100.00 %
Load filling level4	Max. filling level (depending on medium and maximum payload) ▪ Reading in %
Additional pressure5	Enter operating pressure ▪ Yes ▪ No
Operating pressure6	Enter unit for the operating pressure
Unit of 'Operating pressure'7	Selectable units for the operating pressure ▪ bar (default) ▪ kPa ▪ psi
Liquid density8	Density value in kg/m ³ in liquid state ▪ Value in kg/m ³
Standard gas density9	Standard gas density in kg/m ³ ▪ Value in kg/m ³
Gas density in tank10	▪ Settings performed in TROVIS-VIEW

Menu		Adjustment range/values/description
Gas density in low-pressure pipe11	▪ Settings performed in TROVIS-VIEW
Differential pressure mode	2.3	
Differential pressure [Δp_0]	2.3.1	Set the minimum differential pressure. The setting range depends on the entered unit (see parameter 2.3.4).
Differential pressure [Δp_{100}]	2.3.2	Set the maximum differential pressure. The setting range depends on the entered unit (see parameter 2.3.4).
Permissible filling limit	2.3.3	Set the permissible filling limit in %.
Unit	2.3.4	Set the unit for minimum and maximum differential pressure. ▪ Selectable units: mbar · bar · kPa · psi · cmH ₂ O · mH ₂ O · inH ₂ O
Medium identifier	2.3.5	Enter a name (max. 11 characters) to identify the medium.
Additional pressure	2.3.6	Enter operating pressure ▪ Yes ▪ No
Operating pressure	2.3.7	Enter unit for the operating pressure
Unit of 'Operating pressure'	2.3.8	Unit for the operating pressure ▪ Selectable units: mbar · bar · kPa · psi · cmH ₂ O · mH ₂ O · inH ₂ O
Option modules	2.4	
Overview of option modules	2.4.1	
	2.4.1.1	Overview of option modules in four slots as graph, starts option module wizard









Menu		Adjustment range/values/description
Slot 1	2.4.2	<i>The available parameters of inserted options modules are listed depending on the optional additional function.</i>
Slot 2	2.4.3	
Slot 3	2.4.4	
Slot 4	2.4.5	
AO: Analog output option		
Option module identification1	Detection of optional additional function: AO: Analog output
Option module status2	Read the current status of the option module <ul style="list-style-type: none"> ▪ No module inserted ▪ Module not permissible in this setup ▪ Module unknown ▪ Module active
Name3	Enter a name (max. 15 characters) for identification.
Fault alarm output4	Determines the signal for the fault alarm output: 'High' stands for >21 mA, 'Low' for <3.6 mA. <ul style="list-style-type: none"> ▪ High ▪ Low (default)
Error message E15	Determines whether an error message is issued in case of condensed state (E1) (see page 84). <ul style="list-style-type: none"> ▪ No ▪ Yes (default)
Error message E26	Determines whether an error message is issued in case of condensed state (E2) (see page 84). <ul style="list-style-type: none"> ▪ No (default) ▪ Yes
Error message E37	Determines whether an error message is issued in case of condensed state (E3) (see page 84). <ul style="list-style-type: none"> ▪ No (default) ▪ Yes
Assignment of analog output8	Assignment of a measured value for the analog output (in filling level mode) <ul style="list-style-type: none"> ▪ Filling level ▪ Tank pressure (pressure sensor), only when pressure sensor exists

Menu	Adjustment range/values/description
Assignment of analog output9	Assignment of a measured value for the analog output (in differential pressure mode) <ul style="list-style-type: none"> ▪ Differential pressure ▪ Tank pressure (pressure sensor), only when pressure sensor exists
Pressure at 20 mA10	The adaptation to the tank can be made when a pressure sensor is used. <ul style="list-style-type: none"> ▪ 0 to 60 bar (based on 20 mA)
Signal of analog output11	Read the applied signal in %
Start test33	Executable function: two-wire test signal issued.
Test mode34	Test mode is <i>Active</i> while the test is in progress (test duration: 30 s). <ul style="list-style-type: none"> ▪ Not active ▪ Active
Test signal of analog output35	Test signal in % based on the 4 to 20 mA signal range. <ul style="list-style-type: none"> ▪ -10.00 to +110.00 %
AI: Analog input/AIA: Analog input active	
Option module identification1	Detection of optional additional function: AI: Analog input
Option module status2	Read the current status of the option module <ul style="list-style-type: none"> ▪ No module inserted ▪ Module not permissible in this setup ▪ Module unknown ▪ Module active
Name3	Enter a name (max. 15 characters) for identification.
Signal source12	Enter the signal source on which the 4 to 20 mA signal is based <ul style="list-style-type: none"> ▪ Unknown (default) ▪ Filling level ▪ Pressure ▪ Temperature
Medium identifier13	Enter a name (max. 15 characters) to identify the medium. <ul style="list-style-type: none"> ▪ Enter characters as required (default: MEDIUM)
Measured value14	Read the current measured value in the selected unit

Menu		Adjustment range/values/description
Unit15	Unit in which the measured value is to be indicated. <ul style="list-style-type: none"> ▪ Selectable units: % · kg · Nm³ · L · ft³ · lbs · mbar · bar · kPa · psi · mmH₂O · cmH₂O · mH₂O · inH₂O · °C · °F · K
Lower measuring range value16	Determine the lower limit of the measuring range at 4 mA (depending on the selected unit)
Upper measuring range value17	Determine the upper limit of the measuring range at 20 mA (depending on the selected unit)
Event: Broken cable18	Activates or deactivates the event for a detected cable breakage at the input of the AI option module. The event is activated when the signal falls below the switching threshold of 0.2 mA. <ul style="list-style-type: none"> ▪ ON (default) ▪ OFF
Event: Residual current19	Activates or deactivates the event for a detected residual current violation at the input of the AI option module. The event is activated when the signal falls below the switching threshold of 3.6 mA or exceeds 21.0 mA. <ul style="list-style-type: none"> ▪ ON (default) ▪ OFF
Limit 120	Activate/deactivate limit 1 <ul style="list-style-type: none"> ▪ ON (default) ▪ OFF
Mode21	An upper limit can be determined with 'Max. contact' and a lower limit with 'Min. contact' for limit 1. <ul style="list-style-type: none"> ▪ Max. contact ▪ Min. contact
Limit22	Setting limit 1 <ul style="list-style-type: none"> ▪ The limit is set in % when the signal source parameter is set to 'Unknown' or 'Filling level'.
Limit23	Setting limit 1 <ul style="list-style-type: none"> ▪ The limit is set in % when the signal source parameter is set to 'Unknown' or 'Filling level'.
Limit 224	Activate/deactivate limit 2 <ul style="list-style-type: none"> ▪ ON (default) ▪ OFF

Menu		Adjustment range/values/description
Mode25	An upper limit can be determined with 'Max. contact' and a lower limit with 'Min. contact' for limit 2. <ul style="list-style-type: none"> ▪ Max. contact ▪ Min. contact
Limit26	Setting limit 2 <ul style="list-style-type: none"> ▪ The limit is set in % when the signal source parameter is set to 'Unknown' or 'Filling level'.
Limit27	Setting limit 2 <ul style="list-style-type: none"> ▪ The limit is set in % when the signal source parameter is set to 'Unknown' or 'Filling level'.
Limit 328	Activate/deactivate limit 3 <ul style="list-style-type: none"> ▪ ON (default) ▪ OFF
Mode29	An upper limit can be determined with 'Max. contact' and a lower limit with 'Min. contact' for limit 3. <ul style="list-style-type: none"> ▪ Max. contact ▪ Min. contact
Limit30	Setting limit 3 <ul style="list-style-type: none"> ▪ The limit is set in % when the signal source parameter is set to 'Unknown' or 'Filling level'.
Limit31	Setting limit 3 <ul style="list-style-type: none"> ▪ The limit is set in % when the signal source parameter is set to 'Unknown' or 'Filling level'.
4 to 20 mA measured value32	Read the current (in mA) at the option module
Start test33	Executable function: two-wire test signal issued.
Test mode34	Test mode is <i>Active</i> while the test is in progress (test duration: 30 s). <ul style="list-style-type: none"> ▪ Not active ▪ Active
Test signal of analog output36	Test signals (depending on the selected unit) based on the 4 to 20 mA signal range.
Identification		2.5
Firmware version	2.5.1	Read the current firmware version of the Media 7 device
Serial number of Media 7	2.5.2	Read the serial number of the Media 7 device

Menu		Adjustment range/values/description
Serial number of option 1	2.5.3	Read the serial number of the option module in slot 1
Serial number of option 2	2.5.4	Read the serial number of the option module in slot 2
Serial number of option 3	2.5.5	Read the serial number of the option module in slot 3
Serial number of option 4	2.5.6	Read the serial number of the option module in slot 4
Voltage supply	2.5.7	Display the type of voltage supply <ul style="list-style-type: none"> ▪ Unknown ▪ Two-wire ▪ 24 V DC ▪ Explosion-protected, two-wire
HW version/supply voltage	2.5.8	Read the hardware version of the voltage supply
Explosion protection certification	2.5.9	<ul style="list-style-type: none"> ▪ No ▪ Yes
Oxygen approval	2.5.10	<ul style="list-style-type: none"> ▪ No ▪ Yes
Process data	3	
Identifier	3.1	Read the entered identifier
Tank identifier	3.2	Read the tank identifier
Medium identifier	3.3	Read the entered medium identifier
Filling level active	3.4	Read the current filling level in %
Differential pressure active	3.5	Read the current differential pressure in %
Filling level	3.6	Read the current filling level in the selected unit
Pressure sensor	3.7	Read the tank pressure measured by the pressure sensor
Differential pressure [Δp]	3.8	Read the current differential pressure in the selected unit (differential pressure mode)
Differential pressure [Δp]	3.9	Read the current differential pressure in the selected unit (filling level mode)
Zero shift	3.10	Read the zero shift in mbar
Span offset	3.11	Read the span offset in mbar

Menu		Adjustment range/values/description
MCN (total volume)	3.12	Read the maximum tank content in the selected unit
SCN (volume up to gauge pipe)	3.13	Read the tank content up to overflow/gauge pipe in the selected unit
UCW (operating filling limit)	3.14	Read the tank content up to the operating filling limit in the selected unit
Differential pressure [Δp_0]	3.15	Read the minimum differential pressure (differential pressure mode)
Differential pressure [Δp_{100}]	3.16	Read the maximum differential pressure (differential pressure mode)
Differential pressure [Δp_0]	3.17	Read the minimum differential pressure (filling level mode)
Differential pressure [Δp_{100}]	3.18	Read the maximum differential pressure (filling level mode)
Temperature inside device	3.19	Read the current temperature in °C
Heating	3.20	Reading ON/OFF
Measuring range	3.21	Display the measuring range (0 to 3600 mbar)
4-20 mA measured value	3.22	Read measured value in mA (two-wire version only)
Battery voltage	3.23	Read the battery voltage in V
Diagnostics		4
Status messages	4.1	<p>Status messages provide an overview on the current states of individual functions or components of the Media 7 device. A corresponding status icon is assigned to failures and error messages:</p> <ul style="list-style-type: none">  Failure (error class E1)  Out of specification (error class E2)  Maintenance required (error class E3)  No message
Possible status		   

Menu		Adjustment range/values/description			
Media condensed state	4.1.1	•	•	•	•
Condensed state (E1)	4.1.2	•			•
101: AMR magnet	4.1.3	•			•
102: AMR sensor	4.1.4	•			•
103: Memory (calibration)	4.1.5	•			•
104: Memory (data)	4.1.6	•			•
105: Factory calibration	4.1.7	•			•
106: Pressure sensor	4.1.8	•			•
107: Data processing	4.1.9	•			•
Condensed state (E2)	4.1.10		•		•
201: AMR range	4.1.11		•		•
202: Measuring span error	4.1.12		•		•
203: Characteristic error	4.1.13		•		•
204: AMR temperature	4.1.14		•		•
205: Min. temperature	4.1.15		•		•
206: Max. temperature	4.1.16		•		•
207: Differential pressure drop	4.1.17		•		•
Condensed state (E3)	4.1.18		•		•
301: Power supply unit	4.1.19			•	•
302: Option not recognized	4.1.20			•	•
303: Option module combination invalid	4.1.21			•	•
Fault alarm output	4.2				
Fault alarm output	4.2.1	Determines the signal for the fault alarm output: 'High' stands for >21 mA, 'Low' for <3.6 mA. <ul style="list-style-type: none"> ▪ High (default setting) ▪ Low 			

Menu		Adjustment range/values/description
Error message E1	4.2.2	Determines whether an error message is issued in case of condensed state (E1) (see page 84). <ul style="list-style-type: none"> ▪ No ▪ Yes
Error message E2	4.2.3	Determines whether an error message is issued in case of condensed state (E2) (see page 84). <ul style="list-style-type: none"> ▪ No ▪ Yes
Error message E3	4.2.4	Determines whether an error message is issued in case of condensed state (E3) (see page 84). <ul style="list-style-type: none"> ▪ No ▪ Yes
Diagnostic data		4.3
Operation duration	4.3.1	Read the entire operating time of the device (dd:hh:mm:ss)
Temperature		4.4
Temperature inside device	4.4.1	Read the current device temperature in °C
Max. temperature inside device	4.4.2	Set an upper temperature limit within the specified range. If the current device temperature is above the adjusted limit, an error message is generated and displayed. The status changes to 'Out of specification'. <ul style="list-style-type: none"> ▪ 10 to 80 °C (default: 70 °C)
Min. temperature inside device	4.4.3	Set a lower temperature limit within the specified range. If the current device temperature is below the adjusted limit, an error message is generated and displayed. The status changes to 'Out of specification'. <ul style="list-style-type: none"> ▪ -40 to +10 °C (default: -40 °C)
Filling level events		4.5
Filling limit alarm (SCN)	4.5.1	Activate/deactivate the permissible filling level <ul style="list-style-type: none"> ▪ ON ▪ OFF (default)
Pre-alarm	4.5.2	Activate/deactivate the pre-alarm when the filling level falls below the limit. <ul style="list-style-type: none"> ▪ ON (default) ▪ OFF

Menu		Adjustment range/values/description
Limit	4.5.3	Set the limit in % (appears as marking 1 on the display). <ul style="list-style-type: none"> ▪ 0.0 to 100.0 % (default: 30 %)
Main alarm	4.5.4	Activate/deactivate the main alarm when the filling level falls below the limit. <ul style="list-style-type: none"> ▪ ON (default) ▪ OFF
Limit	4.5.5	Set the limit in % (appears as marking 2 on the display). <ul style="list-style-type: none"> ▪ 0.0 to 100.0 % (default: 15 %)
Differential pressure events	4.6	
Filling limit alarm (SCN)	4.6.1	Activate/deactivate the permissible filling level <ul style="list-style-type: none"> ▪ ON ▪ OFF (default)
Pre-alarm	4.6.2	Activate/deactivate the pre-alarm when the filling level falls below the limit. <ul style="list-style-type: none"> ▪ ON (default) ▪ OFF
Limit	4.6.3	Set the limit in % (appears as marking 1 on the display). <ul style="list-style-type: none"> ▪ 0.0 to 100.0 % (default: 30 %)
Main alarm	4.6.4	Activate/deactivate the main alarm when the filling level falls below the limit. <ul style="list-style-type: none"> ▪ ON (default) ▪ OFF
Limit	4.6.5	Set the limit in % (appears as marking 2 on the display). <ul style="list-style-type: none"> ▪ 0.0 to 100.0 % (default: 15 %)
Pressure sensor events	4.7	
Limit 1	4.7.1	Activate/deactivate limit 1 <ul style="list-style-type: none"> ▪ ON (default) ▪ OFF

Menu	Adjustment range/values/description
Mode 4.7.2	An upper pressure limit can be determined with 'Max. contact' and a lower pressure limit with 'Min. contact'. <ul style="list-style-type: none"> ▪ Max. contact (default) ▪ Min. contact
Limit 4.7.3	Set limit 1 in bar <ul style="list-style-type: none"> ▪ 0 to 60 bar (default: 40 bar)
Limit 2 4.7.4	Activate/deactivate limit 2 <ul style="list-style-type: none"> ▪ ON (default) ▪ OFF
Mode 4.7.5	An upper pressure limit can be determined with 'Max. contact' and a lower pressure limit with 'Min. contact'. <ul style="list-style-type: none"> ▪ Max. contact (default) ▪ Min. contact
Limit 4.7.6	Set limit 2 in bar <ul style="list-style-type: none"> ▪ 0 to 60 bar (default: 25 bar)
Limit 3 4.7.7	Activate/deactivate limit 3 <ul style="list-style-type: none"> ▪ ON (default) ▪ OFF
Mode 4.7.8	An upper pressure limit can be determined with 'Max. contact' and a lower pressure limit with 'Min. contact'. <ul style="list-style-type: none"> ▪ Max. contact ▪ Min. contact (default)
Limit 4.7.9	Set limit 3 in bar <ul style="list-style-type: none"> ▪ 0 to 60 bar (default: 5 bar)



1 **EU – Type Examination Certificate**

2 Equipment or Protective System intended for use in Potentially Explosive Atmospheres
Directive 2014/34/EU

3 EU – Type Examination Certificate Number: **KIWA 17ATEX0041 X Issue: 1**

4 Product: **Differential Pressure Gauge / Transmitter Type 5007-1-1x0**

5 Manufacturer: **SAMSON AG**

6 Address: **Weismüllerstraße 3, 60314 Frankfurt
Germany**

7 This product and any acceptable variation thereto is specified in the schedule to this certificate and the documents therein referred to.

8 Kiwa Nederland B.V., Notified Body number 0620 in accordance with Article 17 of Directive 2014/34/EU of the European Parliament and of the Council, dated 26 February 2014, certifies that this product has been found to comply with the Essential Health and Safety Requirements relating to the design and construction of products intended for use in potentially explosive atmospheres given in Annex II to the Directive.
The examination and test results are recorded in confidential ATEX Assessment Report No. 170701565.

9 Compliance with the Essential Health and Safety Requirements has been assured by compliance with:
EN 60079-0 : 2012 + A11 : 2013 EN 60079-11 : 2012 EN 60079-26 : 2015

10 If the sign "X" is placed after the certificate number, it indicates that the product is subject to the Specific Conditions of Use specified in the schedule to this certificate.

11 This EU – Type Examination Certificate relates only to the design and construction of the specified product. Further requirements of the Directive apply to the manufacturing process and supply of this product. These are not covered by this certificate.

12 The marking of the product shall include the following:



II 2 G Ex ia IIB T4 Gb (Type 5007-1-110)
or
II 1/2 G Ex ia IIB T4 Ga/Gb (Type 5007-1-120)

Kiwa Nederland B.V.
Unit Kiwa ExVision
Wilmersdorf 50
P.O. Box 137
7300 AC Apeldoorn
The Netherlands
Tel. +31 88 998 34 83
Fax +31 88 998 36 85
ExVision@kiwa.nl
www.kiwaexvision.com

Kiwa Nederland B.V.

Pieter van Breugel
Certification Officer

Issue date:

1 June 2018

First issue:

This certificate shall, as far as applicable, be revised before the date of cessation of presumption of conformity of (one of) the included standards above as communicated in the Official Journal of the European Union.

© Integral publication of this certificate in its entirety and without any change is allowed.



13 SCHEDULE

14 EU – Type Examination Certificate KIWA 17ATEX0041 X Issue No. 1

15.1 Description of Product

The Differential Pressure Gauges / Transmitters type 5007-1-1x0 are 2 wire loop powered (4 – 20 mA) and are used to convert a differential pressure signal into an electrical signal.

The Gauge consists of a non-metallic enclosure for the electronics, equipped with an indicator for local read-out and a number of push buttons for control, mounted on a differential pressure measuring cell made from brass.

Optionally the Gauge can be equipped with up to 4 additional 4 - 20 mA analog outputs.

Gauges Type 5007-1-120 provide a EPL Ga/Gb separation towards the process in the sensor enclosure, where gauges type 5007-1-110 are equipped with an additional pressure sensor that is in contact with the process.

Ambient temperature range: -20 °C to +70 °C.

15.2 Electrical Data

Supply and output circuit (terminals +31, -31):

in type of protection intrinsic safety Ex ia IIB, only for connection to a certified intrinsically safe circuit, with the following maximum values:

$U_i = 28 \text{ V}$; $I_i = 115 \text{ mA}$; $P_i = 1,0 \text{ W}$; $C_i = 25 \text{ nF}$; $L_i = 0 \text{ mH}$

Output circuit (option module terminals +31, -31):

in type of protection intrinsic safety Ex ia IIB, only for connection to a certified intrinsically safe circuit, with the following maximum values:

$U_i = 28 \text{ V}$; $I_i = 115 \text{ mA}$; $P_i = 1,0 \text{ W}$; $C_i = 25 \text{ nF}$; $L_i = 0 \text{ mH}$

The output circuits of the option modules are galvanically isolated from each other and from the supply and output circuit up to a voltage of 500 V.

15.3 Instructions

The instructions provided with the product shall be followed in detail to assure safe operation.

16 ATEX Assessment Report Number

170701565.

17 Specific Conditions of Use

The equipment shall be installed and maintained such that hazards caused by electrostatic discharge are excluded.

18 Essential Health and Safety Requirements

All relevant Essential Health and Safety Requirements are covered by the standards listed at section 9.

19 Drawings and Documents

As listed in ATEX Assessment Report No. 170701565.





IECEx Certificate of Conformity

INTERNATIONAL ELECTROTECHNICAL COMMISSION IEC Certification Scheme for Explosive Atmospheres

for rules and details of the IECEx Scheme visit www.iecex.com

Certificate No.: IECEx KIWA 17.0020X Issue No: 0 Certificate history:
Issue No. 0 (2018-06-01)

Status: Current Page 1 of 3

Date of Issue: 2018-06-01

Applicant: SAMSON AG
Weismüllerstraße 3
60314 Frankfurt
Germany

Equipment: Differential Pressure Gauge / Transmitter type 5007-1-1x1
Optional accessory:

Type of Protection: Ex ia

Marking: Ex ia IIB T4 Gb (Type 5007-1-111),
Ex ia IIB T4 Ga/Gb (Type 5007-1-121)

Approved for issue on behalf of the IECEx
Certification Body:

Pieter van Breugel

Position:

Certification Officer

Signature:
(for printed version)

Date:

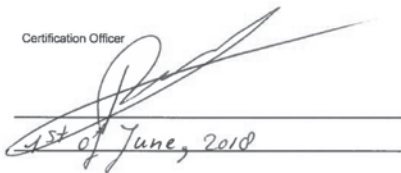
15th of June, 2018

1. This certificate and schedule may only be reproduced in full.
2. This certificate is not transferable and remains the property of the issuing body.
3. The Status and authenticity of this certificate may be verified by visiting the Official IECEx Website.

Certificate issued by:

Kiwa Nederland B.V. (Unit Kiwa ExVision)
Wilmersdorf 50
7327 AC Apeldoorn
P.O. Box 137
The Netherlands





IECEX Certificate of Conformity

Certificate No: IECEX KIWA 17.0020X Issue No: 0
Date of Issue: 2018-06-01 Page 2 of 3
Manufacturer: SAMSON AG
Weismüllerstraße 3
60314 Frankfurt
Germany

Additional Manufacturing location(s):

This certificate is issued as verification that a sample(s), representative of production, was assessed and tested and found to comply with the IEC Standard list below and that the manufacturer's quality system, relating to the Ex products covered by this certificate, was assessed and found to comply with the IECEx Quality system requirements. This certificate is granted subject to the conditions as set out in IECEx Scheme Rules, IECEx 02 and Operational Documents as amended.

STANDARDS:

The apparatus and any acceptable variations to it specified in the schedule of this certificate and the identified documents, was found to comply with the following standards:

IEC 60079-0 : 2011 Edition:3.0	Explosive atmospheres - Part 0: General requirements
IEC 60079-11 : 2011 Edition:3.0	Explosive atmospheres - Part 11: Equipment protection by intrinsic safety "i"
IEC 60079-26 : 2014-10 Edition:3.0	Explosive atmospheres – Part 26: Equipment with Equipment Protection Level (EPL) Ga

This Certificate does not indicate compliance with electrical safety and performance requirements other than those expressly included in the Standards listed above.

TEST & ASSESSMENT REPORTS:

A sample(s) of the equipment listed has successfully met the examination and test requirements as recorded in

Test Report:

NL/KIWA/ExTR17.0022/00

Quality Assessment Report:

DE/TUN/QAR06.0011/07



IECEx Certificate of Conformity

Certificate No: IECEX KIWA 17.0020X

Issue No: 0

Date of Issue: 2018-06-01

Page 3 of 3

Schedule

EQUIPMENT:

Equipment and systems covered by this certificate are as follows:

The Differential Pressure Gauges / Transmitters type 5007-1-1x1 are 2 wire loop powered (4 – 20 mA) and are used to convert a differential pressure signal into an electrical signal. The Gauge consists of a non-metallic enclosure for the electronics, equipped with an indicator for local read-out and a number of push buttons for control, mounted on a differential pressure measuring cell made from brass. Optionally the Gauge can be equipped with up to 4 additional 4 - 20 mA analog outputs.

Gauges Type 5007-1-121 provide a EPL Ga/Gb separation towards the process in the sensor enclosure, where gauges type 5007-1-111 are equipped with an additional pressure sensor that is in contact with the process.

Ambient temperature range: -20 °C to +70 °C.

Electrical Data

Supply and output circuit (terminals +31, -31):

in type of protection intrinsic safety Ex ia IIB, only for connection to a certified intrinsically safe circuit, with the following maximum values:

$U_i = 28 \text{ V}$; $I_i = 115 \text{ mA}$; $P_i = 1.0 \text{ W}$; $C_i = 25 \text{ nF}$; $L_i = 0 \text{ mH}$

Output circuit (option module terminals +31, -31):

in type of protection intrinsic safety Ex ia IIB, only for connection to a certified intrinsically safe circuit, with the following maximum values:

$U_o = 28 \text{ V}$; $I_o = 115 \text{ mA}$; $P_o = 1.0 \text{ W}$; $C_o = 25 \text{ nF}$; $L_o = 0 \text{ mH}$

The output circuits of the option modules are galvanically isolated from each other and from the supply and output circuit up to a voltage of 500 V.

SPECIFIC CONDITIONS OF USE: YES as shown below:

The equipment shall be installed and maintained such that hazards caused by electrostatic discharge are excluded.

EB 9510 EN



SAMSON AKTIENGESELLSCHAFT
Weismüllerstraße 3 · 60314 Frankfurt am Main, Germany
Phone: +49 69 4009-0 · Fax: +49 69 4009-1507
samson@samson.de · www.samson.de