

MOUNTING AND OPERATING INSTRUCTIONS



EB 8061 EN

Translation of original instructions



Type 3254 Valve with Type 3271 Actuator

Type 3254 Valve · ANSI version

In combination with an actuator,
e.g. a Type 3271 or Type 3277 Pneumatic Actuator

Edition January 2021



Note on these mounting and operating instructions

These mounting and operating instructions assist you in mounting and operating the device safely. The instructions are binding for handling SAMSON devices. The images shown in these instructions are for illustration purposes only. The actual product may vary.

- For the safe and proper use of these instructions, read them carefully and keep them for later reference.
- If you have any questions about these instructions, contact SAMSON's After-sales Service (aftersaleservice@samsongroup.com).



Documents relating to the device, such as the mounting and operating instructions, are available on our website at www.samsongroup.com > **Service & Support** > **Downloads** > **Documentation**.

Definition of signal words

DANGER

Hazardous situations which, if not avoided, will result in death or serious injury

WARNING

Hazardous situations which, if not avoided, could result in death or serious injury

NOTICE

Property damage message or malfunction

Note

Additional information

Tip

Recommended action

1	Safety instructions and measures	1-1
1.1	Notes on possible severe personal injury	1-4
1.2	Notes on possible personal injury	1-4
1.3	Notes on possible property damage	1-6
1.4	Notes on the use of an RFID tag	1-7
1.5	Warnings on the device	1-8
2	Markings on the device	2-1
2.1	Valve nameplate	2-1
2.2	Actuator nameplate	2-2
2.3	Material numbers	2-2
2.4	Label when an adjustable packing is installed	2-2
2.5	Optional RFID tag	2-2
3	Design and principle of operation	3-1
3.1	Fail-safe action	3-1
3.2	Versions	3-3
3.3	Additional fittings	3-3
3.4	Valve accessories	3-4
3.5	Technical data	3-4
4	Shipment and on-site transport	4-1
4.1	Accepting the delivered goods	4-1
4.2	Removing the packaging from the valve	4-1
4.3	Transporting and lifting the valve	4-1
4.3.1	Transporting the valve	4-2
4.3.2	Lifting the valve	4-3
4.4	Storing the valve	4-5
5	Installation	5-1
5.1	Installation conditions	5-1
5.2	Preparation for installation	5-2
5.3	Mounting the device	5-3
5.3.1	Mounting the external anti-rotation fixture	5-4
5.3.2	Mounting the actuator onto the valve	5-13
5.3.3	Installing the valve into the pipeline	5-15
5.4	Testing the installed valve	5-16
5.4.1	Leak test	5-17
5.4.2	Travel motion	5-17
5.4.3	Fail-safe position	5-18
5.4.4	Pressure test	5-18

Contents

6	Start-up	6-1
7	Operation	7-1
7.1	Normal operation	7-2
7.2	Manual operation	7-2
8	Malfunctions	8-1
8.1	Troubleshooting	8-1
8.2	Emergency action	8-2
9	Servicing.....	9-1
9.1	Periodic testing	9-3
9.2	Preparing the valve for service work	9-6
9.3	Installing the valve after service work.....	9-7
9.4	Service work.....	9-7
9.4.1	Replacing the top gasket.....	9-7
9.4.2	Replacing the bottom gasket	9-8
9.4.3	Replacing the packing	9-9
9.4.4	Replacing the seat and plug.....	9-14
9.5	Ordering spare parts and operating supplies	9-16
10	Decommissioning	10-1
11	Removal	11-1
11.1	Removing the valve from the pipeline.....	11-2
11.2	Removing the actuator from the valve	11-2
12	Repairs	12-1
12.1	Returning devices to SAMSON	12-1
13	Disposal.....	13-1
14	Certificates.....	14-1
15	Annex.....	15-1
15.1	Tightening torques, lubricants and tools	15-1
15.2	Spare parts	15-2
15.3	After-sales service	15-4

1 Safety instructions and measures

Intended use

The SAMSON Type 3254 Globe Valve in combination with an actuator (e.g. Type 3271 or Type 3277 Pneumatic Actuator) is designed to regulate the flow rate, pressure or temperature of liquids, gases or vapors. The valve with its actuator is designed to operate under exactly defined conditions (e.g. operating pressure, process medium, temperature). Therefore, operators must ensure that the control valve is only used in operating conditions that meet the specifications used for sizing the valve at the ordering stage. In case operators intend to use the control valve in other applications or conditions than specified, contact SAMSON.

SAMSON does not assume any liability for damage resulting from the failure to use the device for its intended purpose or for damage caused by external forces or any other external factors.

➔ Refer to the technical data and nameplate for limits and fields of application as well as possible uses.

Reasonably foreseeable misuse

The control valve is not suitable for the following applications:

- Use outside the limits defined during sizing and by the technical data
- Use outside the limits defined by the valve accessories connected to the valve

Furthermore, the following activities do not comply with the intended use:

- Use of non-original spare parts
- Performing service and repair work not described

Qualifications of operating personnel

The control valve must be mounted, started up, serviced and repaired by fully trained and qualified personnel only; the accepted industry codes and practices must be observed. According to these mounting and operating instructions, trained personnel refers to individuals who are able to judge the work they are assigned to and recognize possible hazards due to their specialized training, their knowledge and experience as well as their knowledge of the applicable standards.

Welding operations must only be performed by personnel who has the necessary qualification to perform the applied welding procedure and handle the materials used.

Safety instructions and measures

Personal protective equipment

We recommend checking the hazards posed by the process medium being used (e.g.

▶ GESTIS (CLP) hazardous substances database). Depending on the process medium and/or the activity, the protective equipment required includes:

- Protective clothing, gloves, eye protection and respiratory protection in applications with hot, cold and/or corrosive media
 - Wear hearing protection when working near the valve
 - Hard hat
 - Safety harness when working at height
 - Safety footwear, ESD (electrostatic discharge) footwear, if necessary
- ➔ Check with the plant operator for details on further protective equipment.

Revisions and other modifications

Revisions, conversions or other modifications of the product are not authorized by SAMSON. They are performed at the user's own risk and may lead to safety hazards, for example. Furthermore, the product may no longer meet the requirements for its intended use.

Safety features

The fail-safe position of the control valve upon air supply or control signal failure depends on the actuator used (see associated actuator documentation). When the valve is combined with a SAMSON Type 3271 or Type 3277 Pneumatic Actuator, the valve moves to a certain fail-safe position (see the 'Design and principle of operation' section) upon supply air or control signal failure. The fail-safe action of the actuator is the same as its direction of action and is specified on the nameplate of SAMSON actuators.

Warning against residual hazards

To avoid personal injury or property damage, plant operators and operating personnel must prevent hazards that could be caused in the control valve by the process medium, the operating pressure, the signal pressure or by moving parts by taking appropriate precautions. Plant operators and operating personnel must observe all hazard statements, warning and caution notes in these mounting and operating instructions.

Hazards resulting from the special working conditions at the installation site of the valve must be identified in a risk assessment and prevented through the corresponding safety instructions drawn up by the operator.

Responsibilities of the operator

Operators are responsible for proper use and compliance with the safety regulations. Operators are obliged to provide these mounting and operating instructions as well as the referenced documents to the operating personnel and to instruct them in proper operation. Furthermore, operators must ensure that operating personnel or third parties are not exposed to any danger.

Operators are additionally responsible for ensuring that the limits for the product defined in the technical data are observed. This also applies to the start-up and shutdown procedures. Start-up and shutdown procedures fall within the scope of the operator's duties and, as such, are not part of these mounting and operating instructions. SAMSON is unable to make any statements about these procedures since the operative details (e.g. differential pressures and temperatures) vary in each individual case and are only known to the operator.

Responsibilities of operating personnel

Operating personnel must read and understand these mounting and operating instructions as well as the referenced documents and observe the specified hazard statements, warnings and caution notes. Furthermore, operating personnel must be familiar with the applicable health, safety and accident prevention regulations and comply with them.

Referenced standards, directives and regulations

The control valves comply with the requirements of the European Pressure Equipment Directive 2014/68/EU and the Machinery Directive 2006/42/EC. Valves with a CE marking have a declaration of conformity which includes information about the applied conformity assessment procedure. The 'Certificates' section contains this declaration of conformity.

According to the ignition hazard assessment performed in accordance with Clause 5.2 of ISO 80079-36, the non-electrical control valves do not have their own potential ignition source even in the rare incident of an operating fault. As a result, they do not fall within the scope of Directive 2014/34/EU.

→ For connection to the equipotential bonding system, observe the requirements specified in section 6.4 of EN 60079-14 (VDE 0165-1).

Referenced documentation

The following documents apply in addition to these mounting and operating instructions:

- Mounting and operating instructions for the mounted actuator, e.g. ► EB 8310-X for Type 3271 or Type 3277 Pneumatic Actuator
- Mounting and operating instructions for mounted valve accessories (positioner, solenoid valve etc.)
- ► AB 0100 for tools and tightening torques
- Manual ► H 02: Appropriate Machinery Components for SAMSON Pneumatic Control Valves with a Declaration of Conformity of Final Machinery
- When a substance is used in the device, which is listed as being a substance of very high concern on the candidate list of the REACH regulation:
Information on safe use of the part affected

► www.samsongroup.com > About SAMSON > Material Compliance > REACH

If a device contains a substance which is listed as being a substance of very high concern on the candidate list of the REACH regulation, this circumstance is indicated on the SAMSON delivery note.

1.1 Notes on possible severe personal injury

DANGER

Risk of bursting in pressure equipment.

Valves and pipelines are pressure equipment. Impermissible pressure or improper opening can lead to valve components bursting.

- ➔ Observe the maximum permissible pressure for valve and plant.
- ➔ Before starting any work on the control valve, depressurize all plant sections affected as well as the valve.
- ➔ Drain the process medium from all the plant sections concerned as well as the valve.

1.2 Notes on possible personal injury

WARNING

Risk of burn injuries due to hot or cold components and pipelines.

Depending on the process medium, valve components and pipelines may get very hot or cold and cause burn injuries.

- Allow components and pipelines to cool down or warm up to the ambient temperature.
- Wear protective clothing and safety gloves.

Risk of hearing loss or deafness due to loud noise.

The noise emissions depend on the valve version, plant facilities and process medium.

- Wear hearing protection when working near the valve.

Risk of personal injury due to exhaust air being vented.

While the valve is operating, air is vented from the actuator, for example, during closed-loop operation or when the valve opens or closes.

- Install the control valve in such a way that vent openings are not located at eye level and the actuator does not vent at eye level in the work position.
- Use suitable silencers and vent plugs.
- Wear eye protection when working in close proximity to the control valve.

Crush hazard arising from moving parts.

The control valve contains moving parts (actuator and plug stem), which can injure hands or fingers if inserted into the valve.

- Do not insert hands or finger into the yoke while the air supply is connected to the actuator.
- Before working on the control valve, disconnect and lock the pneumatic air supply as well as the control signal.
- Do not impede the movement of the actuator and plug stem by inserting objects into the yoke.
- Before unblocking the actuator and plug stem after they have become blocked (e.g. due to seizing up after remaining in the same position for a long time), release any stored energy in the actuator (e.g. spring compression). See associated actuator documentation.

WARNING

Risk of personal injury due to preloaded springs.

Valves in combination with pneumatic actuators with preloaded springs are under tension. These control valves with SAMSON pneumatic actuators can be identified by the long bolts protruding from the bottom of the actuator.

- Before starting any work on the actuator, relieve the compression from the preloaded springs (see associated actuator documentation).

Risk of personal injury due to residual process medium in the valve.

While working on the valve, residual medium can flow out of the valve and, depending on its properties, cause personal injury, e.g. (chemical) burns.

- If possible, drain the process medium from all the plant sections affected and the valve.
- Wear protective clothing, safety gloves, respiratory protection and eye protection.

Risk of personal injury through incorrect operation, use or installation as a result of information on the valve being illegible.

Over time, markings, labels and nameplates on the valve may become covered with dirt or become illegible in some other way. As a result, hazards may go unnoticed and the necessary instructions not followed. There is a risk of personal injury.

- Keep all relevant markings and inscriptions on the device in a constantly legible state.
- Immediately renew damaged, missing or incorrect nameplates or labels.

1.3 Notes on possible property damage

! NOTICE

Risk of valve damage due to contamination (e.g. solid particles) in the pipeline.

The plant operator is responsible for cleaning the pipelines in the plant.

→ Flush the pipelines before start-up.

Risk of valve damage due to unsuitable medium properties.

The valve is designed for a process medium with defined properties.

→ Only use the process medium specified for sizing the valve.

Risk of leakage and valve damage due to excessively high or low tightening torques.

Observe the specified torques when tightening control valve components. Excessive tightening torques lead to parts wearing out more quickly. Parts that are too loose may cause leakage.

→ Observe the specified tightening torques (▶ AB 0100).

Risk of valve damage due to the use of unsuitable tools.

Certain tools are required to work on the valve.

→ Only use tools approved by SAMSON (▶ AB 0100).

Risk of valve damage due to the use of unsuitable lubricants.

The lubricants to be used depend on the valve material. Unsuitable lubricants may corrode and damage surfaces.

→ Only use lubricants approved by SAMSON (▶ AB 0100).

Risk of the process medium being contaminated through the use of unsuitable lubricants and/or contaminated tools and components.

→ If necessary, keep the valve and the tools used free from solvents and grease.

→ Make sure that only suitable lubricants are used.

1.4 Notes on the use of an RFID tag

The RFID tag is subject to certain restrictions due to its application range (technical specifications).

- Observe the explosion protection certificates of the RFID tag when it is to be used on valves installed in potentially explosive atmospheres.
- Do not expose the RFID tag to strong electric fields.
- Avoid electrostatic charging.
- Observe the application range (technical specifications) of the RFID tag.

1.5 Warnings on the device

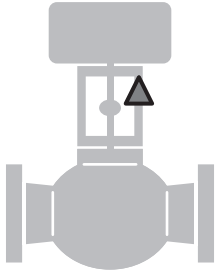
Warning	Meaning of the warning	Location on the device
	<p>Warning against moving parts There is a risk of injury to hands or fingers through the stroking movement of the actuator and plug stem if they are inserted into the yoke while the air supply is connected to the actuator.</p>	

2 Markings on the device

2.1 Valve nameplate

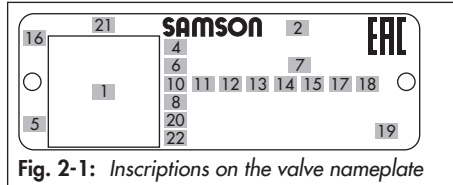

Fig. 2-1: Inscriptions on the valve nameplate

i Note

Fig. 2-1 and the inscription table list all possible characteristics and options that may appear on a valve nameplate. Only the inscriptions relevant to the ordered Type 3254 Valve actually appear on the nameplate.

Item	Inscription meaning
1	Data Matrix code
2	Type designation
4	Material
5	Month and year of manufacture
6	Valve size: DIN: DN · ANSI: NPS · JIS: DN
7	Pressure rating: DIN: PN · ANSI: CL · JIS: K
8	Order number/item
10	Flow coefficient: DIN: KVS · ANSI: CV
11	Characteristic: %: equal percentage · LIN : linear mod-lin : modified linear NO/NC : on/off service
12	Seat-plug seal: ME : metal · HA : carbide metal · ST : metal base material with Stellite® facing KE : ceramic · PT : PTFE soft seal · PK : PEEK soft seal
13	Seat code (trim material): on request
14	Pressure balancing: DIN: D · ANSI/JIS: B Version: M : mixing valve · V : flow-diverting valve

Item	Inscription meaning
15	Noise reduction: 1 : flow divider (ST) 1 · 2 : ST 2 · 3 : ST 3 1/PSA : ST 1 standard and integrated in seat for PSA valve AC-1/AC-2/AC-3/AC-5 : AC trim, versions 1 to 5 · LK : perforated plug LK1/LK2/LK3 : perforated plug with flow divider ST 1 to ST 3 · MHC1 : multi-hole cage · CC1 : Combi Cage · ZT1 : Zero Travel
16	Country of origin
17	PSA version: PSA
18	Cage/seat style: CC : clamped cage, clamped seat SF : suspended cage, flanged seat
19	CE marking
20	ID of the notified body PED : Pressure Equipment Directive G1/G2 : gases and vapors Fluid group 1 = hazardous Fluid group 2 = other L1 : liquids Fluid group 1 = hazardous Fluid group 2 = other I/II/III : Category 1 to 3
21	Serial number
22	NE 53 (NAMUR Recommendation)

Markings on the device

The nameplate (80) is affixed to the yoke of the valve (see Fig. 2-2).

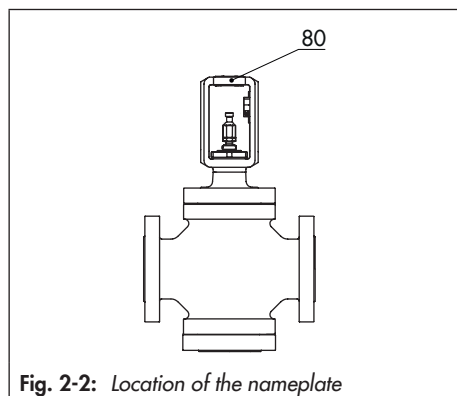

Fig. 2-2: Location of the nameplate

2.2 Actuator nameplate

See associated actuator documentation.

2.3 Material numbers

The seat and plug of the valves have an item number written on them. You can contact us stating this item number to find out which material is used. Additionally, a seat code is used to identify the trim material. This seat code is specified on the nameplate.

2.4 Label when an adjustable packing is installed

An instructional label is affixed to the valve when an adjustable packing is installed (see Fig. 2-3).



Fig. 2-3: Label when an adjustable packing is installed

2.5 Optional RFID tag

The RFID tag is located directly next to the nameplate on valves ordered with the RFID tag option. It contains the same data as included in the Data Matrix code on the electronic nameplate. It can be read using a smartphone, tablet or RFID reader.

Application range according to the technical data (see the 'Design and principle of operation' section).

3 Design and principle of operation

The Type 3254 Valve is a single-seated globe valve. This valve is preferably combined with a SAMSON Type 3271 or Type 3277 Pneumatic Actuator (see Fig. 3-1). It can also be combined with other actuators.

The seat (4) and plug with plug stem (5) are installed in the body (1). An additional plug stem guide exists in the bottom body flange (100), which prevents the plug stem from oscillating. The plug stem is connected to the actuator stem (A7) by the stem connector clamps (A26/27) and is sealed by a spring-loaded V-ring packing (15). The springs in the pneumatic actuator are located either above or below the diaphragm (A4) depending on the selected fail-safe action. A change in the signal pressure acting on the diaphragm causes the plug to move. The actuator size is determined by the diaphragm area.

The medium flows through the valve in the direction indicated by the arrow. A rise in signal pressure causes the force acting on the diaphragm in the actuator to increase. The springs are compressed. Depending on the selected direction of action, the actuator stem retracts or extends. As a result, the plug position in the seat changes and determines the flow rate through the valve.



Tip
We recommend the use of positioners with integrated diagnostic firmware (see section 3.4) for valves used for on/off service.

The partial stroke test included in this software helps prevent a shut-off valve normally in its end position from seizing up or getting jammed.

3.1 Fail-safe action

The fail-safe position of the control valve upon air supply or control signal failure depends on the actuator used (see associated actuator documentation).

Depending on how the compression springs are arranged in the SAMSON Type 3271 and Type 3277 Pneumatic Actuator, the valve has one of two different fail-safe positions:

Actuator stem extends (FA)

When the signal pressure is reduced or the air supply fails, the springs move the actuator stem downward and close the valve. The valve opens when the signal pressure is increased enough to overcome the force exerted by the springs.

Actuator stem retracts (FE)

When the signal pressure is reduced or the air supply fails, the springs move the actuator stem upwards and open the valve. The valve closes when the signal pressure is increased enough to overcome the force exerted by the springs.



Tip
The actuator's direction of action can be reversed, if required. Refer to the mounting and operating instructions of the pneumatic actuator:

► EB 8310-X for Type 3271 and Type 3277

Design and principle of operation

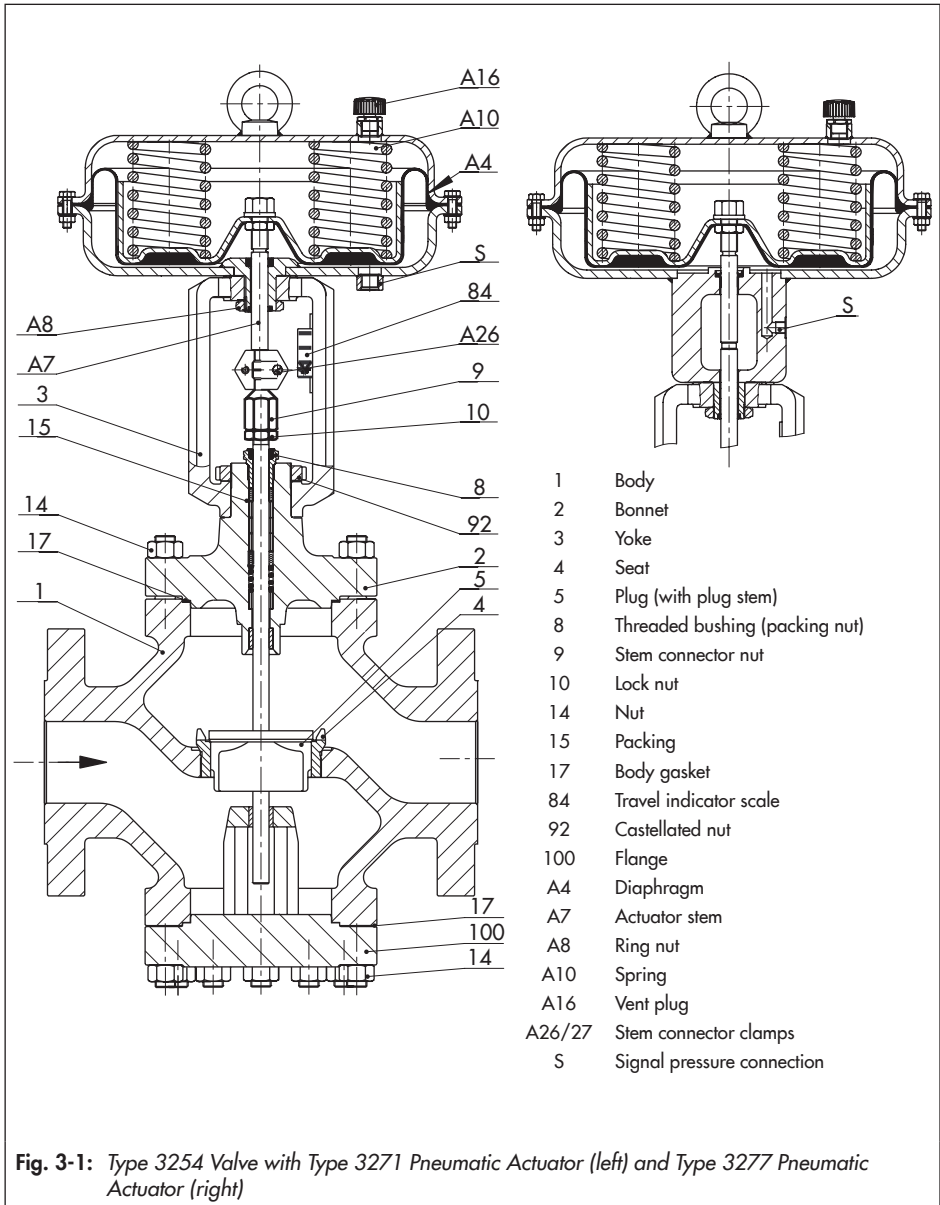

3.2 Versions

With insulating section/bellows seal

The modular design allows an insulating section or bellows seal to be fitted to the standard valve version.

Actuators

In these instructions, the preferable combination with a SAMSON Type 3271 or Type 3277 Pneumatic Actuator is described. The pneumatic actuator (with or without handwheel) can be replaced by another pneumatic actuator in a different size, but with the same travel.

- ➔ Observe the maximum permissible actuator force.

i Note

If the travel range of the actuator is larger than the travel range of the valve, the spring assembly in the actuator must be preloaded so that the travel ranges match. See associated actuator documentation.

The basic pneumatic actuator can be replaced by a pneumatic actuator with additional handwheel or by an electric actuator (see Information Sheet ► T 8300).

3.3 Additional fittings

Strainers

We recommend installing a SAMSON strainer upstream of the valve. It prevents solid particles in the process medium from damaging the valve.

Bypass and shut-off valves

We recommend installing a shut-off valve both upstream of the strainer and downstream of the valve and installing a bypass line. The bypass ensures that the plant does not need to be shut down for service and repair work on the valve.

Insulation

Control valves can be insulated to reduce heat energy transfer.

Refer to the instructions in the 'Installation' section.

Test connection

Versions with bellows seal fitted with a test connection (G 1/8) at the top flange allow the sealing ability of the bellows to be monitored.

Particularly for liquids and vapors, we recommend installing a suitable leakage indicator (e.g. a contact pressure gauge, an outlet to an open vessel or an inspection glass).

Safety guard

For operating conditions that require increased safety (e.g. in cases where the valve is freely accessible to untrained staff), a safety guard must be installed to rule out a crush hazard arising from moving parts (actuator and plug stem). Plant operators are responsible for deciding whether a guard is to be used. The decision is based on the risk posed by the plant and its operating conditions.

Noise emissions

Trims with flow dividers can be used to reduce noise emission (► T 8081).

3.4 Valve accessories

Information Sheet ► T 8350

3.5 Technical data

The nameplates on the valve and actuator provide information on the control valve version. See the 'Markings on the device' section.

i Note

More information is available in Data Sheet ► T 8061.

Conformity

The Type 3254 Valve bears both the CE and EAC marks of conformity.



Temperature range

Depending on the version, the control valve is designed for a temperature range from -10 to +220 °C (14 to 428 °F). The use of an insulating section or bellows seal can extend the temperature range from -196 to +550 °C (-325 to +1022 °F) depending on the properties of the materials used.

Leakage class

Depending on the version, the following leakage class applies:

Seal (12 on nameplate)	ME, ST	ME, ST	PT, PK
Pressure balancing (14 on nameplate)	–	D/B	–
Leakage class (according to ANSI/FCI 70-2)	Min. IV	Min. IV	VI

Noise emissions

SAMSON is unable to make general statements about noise emissions. The noise emissions depend on the valve version, plant facilities and process medium.

Optional RFID tag

Application range according to the technical specifications and the explosion protection certificates. These documents are available on our website at ► www.samsongroup.com > Service & Support > Electronic nameplate.

Dimensions and weights

Table 3-1 to Table 3-3 provide an overview of the dimensions and weights of the Type 3254 Valve. The lengths and heights in the dimensional drawings are shown on page 3-8.

Dimensions (in inch and mm) and weights (in lbs and kg)

Face-to face dimensions according to ANSI/ISA-75.08.01 for Class 600 and lower and according to ASME B16.10 for Class 900 and higher

Table 3-1: *Dimensions and weights for Type 3254 · Standard version*

Table 3-1.1: *Valve size NPS 3 to 8 (DN 80 to 200)*

Valve		NPS	3	4	6	8
		DN	80	100	150	200
Length L (flanges RF and weld- ing ends)	Class 150	in	11.75	13.88	17.75	21.38
		mm	298	352	451	543
	Class 300	in	12.50	14.50	18.62	22.38
		mm	318	368	473	568
	Class 600	in	13.25	15.50	20.00	24.00
		mm	337	394	508	610
	Class 900	in	15.00	18.00	24.00	29.00
		mm	381	457	610	737
	Class 1500	in	18.50	21.50	27.75	32.75
		mm	470	546	705	832
	Class 2500	in	22.75	26.50	36.00	40.25
		mm	578	673	914	1022
Height H4	Class 150 to 600	in	8.74	9.53	12.37	15.24
		mm	222	242	314	387
	Class 900	in	8.74	9.53	12.37	15.24
		mm	222	242	314	387
	Class 1500 to 2500	in	11.34	13.7	17.56	22.44
		mm	288	348	446	570

Design and principle of operation

Valve		NPS	3	4	6	8	
		DN	80	100	150	200	
H8 for actuator	350 cm ²	in	9.45	9.45	-		
		mm	240	240			
	355 cm ²	in	9.45	9.45	16.46	-	
		mm	240	240	418		
	700 cm ²	in	9.45	9.45	16.46	16.46	
		mm	240	240	418	418	
	750 cm ²	in	9.45	9.45	16.46	16.46	
		mm	240	240	418	418	
	1000 cm ²	in	11.61	11.61	16.46	16.46	
		mm	295	295	418	418	
H8 for actuator	1400-60 cm ²	in	11.61	11.61	16.46	16.46	
		mm	295	295	418	418	
	1400-120 cm ²	in	18.90	18.90	19.80	19.80	
		mm	480	480	503	503	
	2800 cm ²	in	18.90	18.90	19.80	19.80	
		mm	480	480	503	503	
	2x2800 cm ²	in	18.90	18.90	19.80	19.80	
		mm	480	480	503	503	
H2	Class 150	in	6.89	8.15	11.34	15.35	
		mm	175	207	288	390	
	Class 300 to 600	in	8.74	9.80	13.31	15.35	
		mm	222	249	338	390	
	Class 900	in	8.74	9.80	13.31	15.35	
		mm	222	249	338	390	
	Class 1500	in	11.02	12.24	17.40	20.87	
		mm	280	311	442	530	
	Class 2500	in	11.02	13.11	17.72	On request	
		mm	280	333	450		

Table 3-1.2: Valve size NPS 10 to 20 (DN 250 to 500)

Valve		NPS	10	12	16	20
		DN	250	300	400	500
Length L (flanges RF and weld- ing ends)	Class 150	in	26.50	29.00	40.00	49.88 ⁵⁾
		mm	673	737	1016	1267 ⁵⁾
	Class 300	in	27.88	30.50	41.62	51.50 ⁵⁾
		mm	708	775	1057	1308 ⁵⁾
	Class 600	in	29.62	32.25	43.62	54.02 ⁵⁾
		mm	752	819	1108	1372 ⁵⁾
	Class 900	in	33.00	38.00	44.50	On request
		mm	838	965	1130	
	Class 1500	in	39.00	44.50	54.50	On request
		mm	991	1130	1384	
Class 2500	in	50.00	56.00	-		
	mm	1270	1422			
Height H4	Class 150 to 600	in	17.41 ¹⁾	25.79	25.20	32.28
		mm	442 ¹⁾	655	640	820
	Class 900	in	20.43 ²⁾	25.79	On request	On request
		mm	519 ²⁾	655		
	Class 1500 to 2500	in	On request	On request	On request ³⁾	On request ³⁾
		mm				
H8 for actuator	350 cm ²	in	-			
		mm				
	355 cm ²	in	-	-		
		mm				
	700 cm ²	in	16.46			
		mm	418			
	750 cm ²	in	16.46			
		mm	418			
1000 cm ²	in	On request				
	mm					
1400- 60 cm ²	in	On request	On request			
	mm					
1400- 120 cm ²	in	19.80	25.59	25.59	25.59	
	mm	503 ⁴⁾	650	650	650	

Design and principle of operation

Valve		NPS	10	12	16	20
		DN	250	300	400	500
H8 for actuator	2800 cm ²	in	19.80	25.59	25.59	25.59
		mm	503 ⁴⁾	650	650	650
	2x2800 cm ²	in	19.80	25.59	25.59	25.59
		mm	503 ⁴⁾	650	650	650
H2	Class 150	in	16.14	18.90	22.05	24.80
		mm	410	480	560	630
	Class 300 to 600	in	16.14	18.90	25.59	28.94
		mm	410	480	650	735
	Class 900	in	16.14	18.90	On request	
		mm	410	480		
	Class 1500	in	26.77	29.92	On request	
		mm	680	760		
	Class 2500	in	On request			
		mm				

1) NPS 10 in Class 150 to 300: 442 mm/17.40 in

2) NPS 10 in Class 600 to 900: 519 mm/20.43 in

3) Class 1500

4) H8 = 650 mm with 250 mm seat bore

5) Face-to-face dimensions according to SAMSON standard

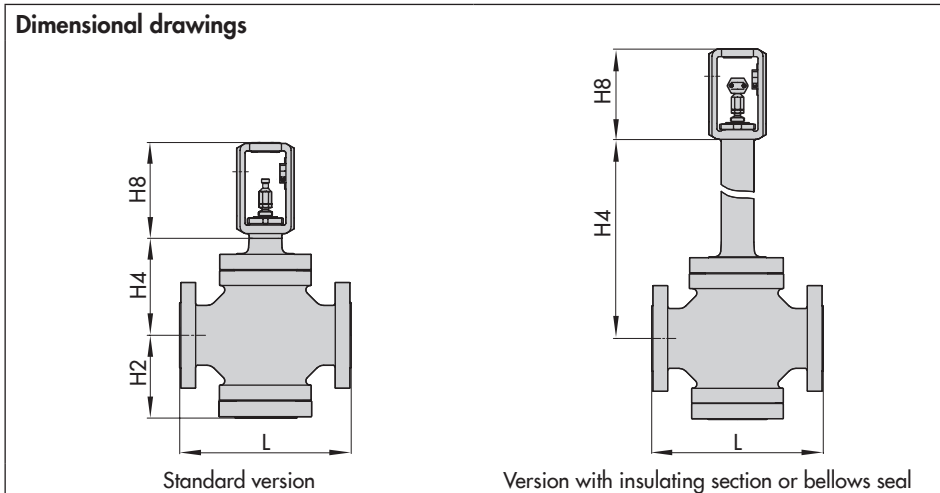

Table 3-1.3: *Weights for Type 3254 · Standard version*

Valve		NPS	3	4	6	8	10	12	16	20	
		DN	80	100	150	200	250	300	400	500	
Weight for valve without actuator	Class 150	lbs	130	179	410	948	2138	2381	4255	On req.	
		kg	59	81	186	430	970	1080	1930		
	Class 300	lbs	196	287	785	948	2138	2381	4255	On req.	
		kg	89	130	356	430	970	1080	1930		
	Class 600	lbs	196	287	785	1323	2509	3417	6173	On req.	
		kg	89	130	356	600	1138	1550	2800		
	Class 900	lbs	196	287	785	1415	3009	3902	6834	On req.	
		kg	89	130	356	642	1365	1770	3100		
	Class 1500	lbs	On request								
		kg									
	Class 2500	lbs									
		kg									

Table 3-2: *Dimensions and weights for Type 3254 Valve · Version with insulating section*

Table 3-2.1: *Valve size NPS 3 to 8 (DN 80 to 200)*

Valve size		NPS	3	4	6	8
		DN	80	100	150	200
Height H4	Class 150 to 600	in	19.37	20.16	26.18	37.28
		mm	492	512	665	947
	Class 900	in	19.37	20.16	26.18	37.28
		mm	492	512	665	947
	Class 1500 to 2500	in	21.5	23.54	31.10	42.13
		mm	546	598	790	1070

Design and principle of operation

Valve size		NPS	3	4	6	8
		DN	80	100	150	200
Weight without actuator for	Class 150	lbs	174	223	454	1045
		kg	79	101	206	474
	Class 300	lbs	240	331	829	1045
		kg	109	150	376	474
	Class 600	lbs	240	331	829	1420
		kg	109	150	376	644
	Class 900	lbs	240	331	829	1512
		kg	109	150	376	686
Class 1500 to 2500	lbs	On request				
	kg					

Table 3-2.2: Valve size NPS 10 to 20 (DN 250 to 500)

Valve size		NPS	10	12	16	20	
		DN	250	300	400	500	
Height H4	Class 150 to 600	in	42.01	45.32	44.76	On request	
		mm	1067	1151	1137		
	Class 900	in	42.01	On request			
		mm	1067				
	Class 1500 to 2500	in	On request		Class 1500 On request		
		mm					
Weight without actuator for	Class 150	lbs	2271	2476	4350	On request	
		kg	1030	1123	1973		
	Class 300	lbs	2271	2476	4350		
		kg	1030	1123	1973		
	Class 600	lbs	2641	3512	6268		
		kg	1198	1593	2843		
	Class 900	lbs	3201	3997	6929		
		kg	1452	1813	3143		
	Class 1500 to 2500	lbs	On request		Class 1500 On request		
		kg					

Table 3-3: Dimensions and weights for Type 3254 Valve · Version with bellows seal

Table 3-3.1: Valve size NPS 3 to 8 (DN 80 to 200)

Valve size		NPS	3	4	6	8		
		DN	80	100	150	200		
		Travel						
Height H4	Class 150	0.59" to 2.36" 15 to 60 mm	24.13	24.13	27.72	-		
			613	613	704			
	Class 300 to 900		24.13	24.13	32.96			
			613	613	837			
	Class 1500	in	0.59	34.02	On request			
		mm	15	864	On request			
		in	1.18	34.02	On request			
		mm	30	864	On request			
		in	2.36	-			On request	
		mm	60	-			On request	
	Class 2500	in	0.59	40.16	On request			
		mm	15	1020	On request			
		in	1.18	40.16	On request			
		mm	30	1020	On request			
		in	2.36	-			On request	
		mm	60	-			On request	
	Class 150 to 300	in	1.18 to 4.72	-			41.22	
		mm	30 to 120	-			1047	
	Class 600 to 900	in	1.18 to 2.36	-			62.24	
		mm	30 to 60	-			1581	
Class 600	in	4.72	-			-		
	mm	120	-			-		
Weight for valve with bellows seal (without actua- tor) for	Class 150	lbs	190	247	474	1146		
		kg	86	112	215	520		
	Class 300	lbs	262	353	882	1146		
		kg	119	160	400	520		
	Class 600	lbs	262	353	882	1521		
		kg	119	160	400	690		
	Class 900	lbs	262	353	882	1609		
		kg	119	160	400	730		
	Class 1500 and 2500	lbs	On request					
		kg	On request					

Design and principle of operation

Table 3-3.2: Valve size NPS 10 to 20 (DN 250 to 500)

Valve size		NPS	10	12	16	20					
		DN	250	300	400	500					
		Travel									
Height H4	Class 150	0.59" to 2.36" 15 to 60 mm	-								
	Class 300 to 900										
		in					0.59				
		mm					15				
	Class 1500	in					1.18				
		mm					30				
		in					2.36				
		mm					60				
		in					0.59				
		mm					15				
	Class 2500	in					1.18				
		mm					30				
		in					2.36				
		mm					60				
	Class 150 to 300	in					1.18 to 4.72	59.13	60.20	59.69	62.60
		mm					30 to 120	1502	1529	1516	1590
Class 600 to 900	in	1.18 to 2.36	62.68	64.96	On request						
	mm	30 to 60	1592	1650							
Class 600	in	4.72	94.65	91.42	90.16	On re- quest					
	mm	120	2404	2322	2290						
Weight for valve with bellows seal (without actuator) for	Class 150	lbs	-	2370	2575	4453	On re- quest				
		kg		1075	1168	2020					
	Class 300	lbs		2370	2575	4453					
		kg		1075	1168	2020					
	Class 600	lbs		2745	3616	6371					
		kg		1245	1640	2890					
	Class 900	lbs		3307	4101	7033					
		kg		1500	1860	3190					
	Class 1500 and 2500	lbs		On request				On re- quest			
		kg									

i Note

The associated actuator documentation applies to actuators, e.g. SAMSON pneumatic actuators:

- ▶ *T 8310-1 for Type 3271 or Type 3277 Pneumatic Actuators up to 750 cm² actuator area*
 - ▶ *T 8310-2 for Type 3271 Actuator with 1000 cm² actuator area and larger*
 - ▶ *T 8310-3 for Type 3271 Actuator with 1400-60 cm² actuator area*
-

4 Shipment and on-site transport

The work described in this section is only to be performed by personnel appropriately qualified to carry out such tasks.

4.1 Accepting the delivered goods

After receiving the shipment, proceed as follows:

1. Check the scope of delivery. Check that the specifications on the valve nameplate match the specifications in the delivery note. See the 'Markings on the device' section for nameplate details.
2. Check the shipment for transportation damage. Report any damage to SAMSON and the forwarding agent (refer to delivery note).
3. Determine the weight and dimensions of the units to be lifted and transported in order to select the appropriate lifting equipment and lifting accessories. Refer to the transport documents and the 'Technical data' section.

4.2 Removing the packaging from the valve

Observe the following sequence:

- Do not open or remove the packaging until immediately before lifting to install the valve into the pipeline.

- Leave the control valve in its transport container or on the pallet to transport it on site.
- Do not remove the protective caps from the inlet and outlet until immediately before installing the valve into the pipeline. They prevent foreign particles from entering the valve.
- Dispose and recycle the packaging in accordance with the local regulations.

4.3 Transporting and lifting the valve

⚠ DANGER

Danger due to suspended loads falling.

- *Stay clear of suspended or moving loads.*
 - *Close off and secure the transport paths.*
-

⚠ WARNING

Risk of lifting equipment tipping over and risk of damage to lifting accessories due to exceeding the rated lifting capacity.

- *Only use approved lifting equipment and accessories whose minimum lifting capacity is higher than the weight of the valve (including actuator and packaging, if applicable).*
-

WARNING

Risk of personal injury due to the control valve tipping over.

- Observe the valve's center of gravity.
 - Secure the valve against tipping over or turning.
-

WARNING

Risk of injury due to incorrect lifting without the use of lifting equipment.

Lifting the control valve without the use of lifting equipment may lead to injuries (back injury in particular) depending on the weight of the control valve.

- Observe the occupational health and safety regulations valid in the country of use.
-

NOTICE

Risk of valve damage due to incorrectly attached slings.

The lifting eyelet/eyebolt on SAMSON actuators is only intended for mounting and removing the actuator as well as lifting the actuator without valve. Do not use this lashing point to lift the entire control valve assembly.

- When lifting the control valve, make sure that the slings attached to the valve body bear the entire load.
 - Do not attach load-bearing slings to the actuator, handwheel or any other parts.
 - Observe lifting instructions (see section 4.3.2).
-

Tip

A swivel hoist can be screwed into SAMSON actuators with a female thread on the top diaphragm case in place of the eyebolt (see associated actuator documentation).

In contrast to the lifting eyelet/eyebolt, the swivel hoist is designed for setting a control valve assembly upright.

The sling between the swivel hoist and rigging equipment (hook, shackle etc.) must not bear any load when lifting a control valve assembly. The sling only protects the control valve from tilting while being lifted.

Tip

Our after-sales service can provide more detailed transport and lifting instructions on request.

4.3.1 Transporting the valve

The control valve can be transported using lifting equipment (e.g. crane or forklift).

- Leave the control valve in its transport container or on the pallet to transport it.
- Observe the transport instructions.

Transport instructions

- Protect the control valve against external influences (e.g. impact).
- Do not damage the corrosion protection (paint, surface coatings). Repair any damage immediately.

- Protect the piping and any mounted valve accessories against damage.
- Protect the control valve against moisture and dirt.
- The permissible transportation temperature of standard control valves is -20 to $+65$ °C (-4 to $+149$ °F).

i Note

Contact our after-sales service for the transportation temperatures of other valve versions.

4.3.2 Lifting the valve

To install a large valve into the pipeline, use lifting equipment (e.g. crane or forklift) to lift it.

Lifting instructions

- Use a hook with safety latch (see Fig. 4-1) to secure the slings from slipping off the hook during lifting and transporting.
- Secure slings against slipping.
- Make sure the slings can be removed from the valve once it has been installed into the pipeline.
- Prevent the control valve from tilting or tipping over.

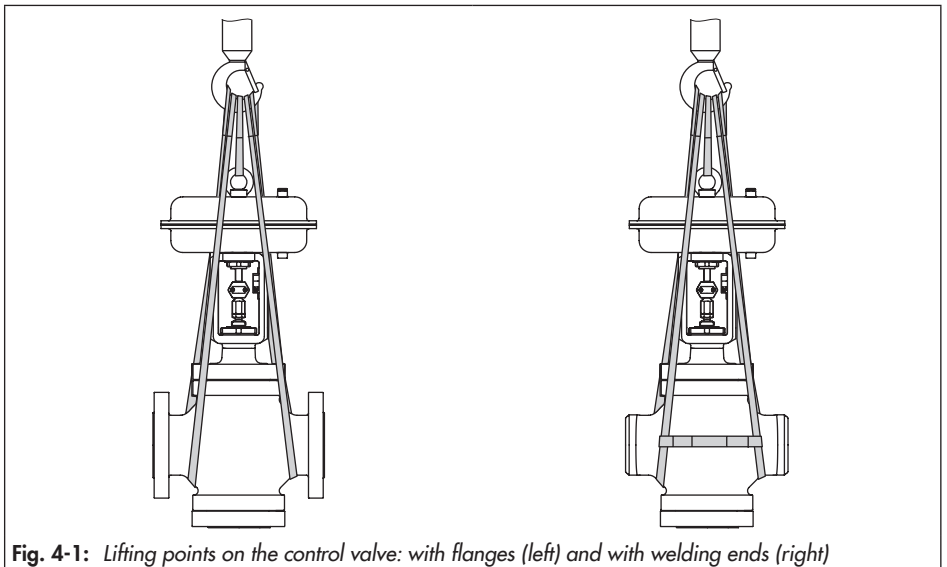

Fig. 4-1: Lifting points on the control valve: with flanges (left) and with welding ends (right)

Shipment and on-site transport

- Do not leave loads suspended when interrupting work for longer periods of time.
- Make sure that the axis of the pipeline is always horizontal during lifting and the axis of the plug stem is always vertical.
- Make sure that the additional sling between the lashing point on the actuator and rigging equipment (hook, shackle etc.) does not bear any load when lifting valves with an actuator that has a lifting eyelet/eyebolt on it. The sling only protects the control valve from tilting while being lifted. Before lifting the control valve, tighten the sling.

a) Version with flanges

1. Attach one sling to each flange of the body and to the rigging equipment (e.g. hook) of the crane or forklift (see Fig. 4-1).
2. **NPS 6 and larger:** attach another sling to the lashing point on the actuator and to the rigging equipment.
3. Carefully lift the control valve. Check whether the lifting equipment and accessories can bear the weight.
4. Move the control valve at an even pace to the site of installation.
5. Install the valve into the pipeline (see the 'Installation' section).
6. After installation in the pipeline, check whether the flanges are bolted tight and the valve in the pipeline holds.
7. Remove slings.

b) Version with welding ends

1. Attach one sling to each welding end of the body and to the rigging equipment (e.g. hook) of the crane or forklift (see Fig. 4-1).
2. Secure the slings attached to the body against slipping using a connector.
3. **NPS 6 and larger:** attach another sling to the lashing point on the actuator and to the rigging equipment.
4. Carefully lift the control valve. Check whether the lifting equipment and accessories can bear the weight.
5. Move the control valve at an even pace to the site of installation.
6. Install the valve into the pipeline (see the 'Installation' section).
7. After installation, check whether the weld seams hold.
8. Remove slings.

4.4 Storing the valve

NOTICE

Risk of valve damage due to improper storage.

- Observe the storage instructions.
- Avoid long storage times.
- Contact SAMSON in case of different storage conditions or longer storage times.

Note

We recommend regularly checking the control valve and the prevailing storage conditions during long storage periods.

Storage instructions

- Protect the control valve against external influences (e.g. impact).
- Secure the valve in the stored position against slipping or tipping over.
- Do not damage the corrosion protection (paint, surface coatings). Repair any damage immediately.
- Protect the control valve against moisture and dirt. Store it at a relative humidity of less than 75 %. In damp spaces, prevent condensation. If necessary, use a drying agent or heating.
- Make sure that the ambient air is free of acids or other corrosive media.
- The permissible storage temperature of standard control valves is -20 to $+65$ °C (-4 to $+149$ °F). Contact our after-sales

service for the storage temperatures of other valve versions.

- Do not place any objects on the control valve.

Special storage instructions for elastomers

Elastomer, e.g. actuator diaphragm

- To keep elastomers in shape and to prevent cracking, do not bend them or hang them up.
- We recommend a storage temperature of 15 °C (59 °F) for elastomers.
- Store elastomers away from lubricants, chemicals, solutions and fuels.

Tip

Our after-sales service can provide more detailed storage instructions on request.

5 Installation

The work described in this section is only to be performed by personnel appropriately qualified to carry out such tasks.

5.1 Installation conditions

Work position

The work position for the control valve is the front view looking onto the operating controls (including valve accessories).

Plant operators must ensure that, after installation of the device, the operating personnel can perform all necessary work safely and easily access the device from the work position.

Pipeline routing

The inlet and outlet lengths (see Table 5-1) vary depending on several variables and process conditions and are intended as recommendations. Contact SAMSON if the lengths are significantly shorter than the recommended lengths.

To ensure that the valve functions properly, proceed as follows:

- ➔ Observe the inlet and outlet lengths (see Table 5-1). Contact SAMSON if the valve conditions or states of the medium process deviate.
- ➔ Install the valve free of stress and with the least amount of vibrations as possible. Read information under 'Mounting position' and 'Support or suspension' in this section.

- ➔ Install the valve allowing sufficient space to remove the actuator and valve or to perform service work on them.

Mounting position

Generally, we recommend installing the valve with the actuator upright and on top of the valve.

In the following versions, the valve **must** be installed with the actuator on top:

- Valves in NPS 4 and larger
- Valves with insulating section for low temperatures below $-10\text{ }^{\circ}\text{C}$ ($14\text{ }^{\circ}\text{F}$)

- ➔ Contact SAMSON if the mounting position is not as specified above.

Support or suspension

i Note

The plant engineering company is responsible for selecting and implementing a suitable support or suspension of the installed control valve and the pipeline.

Depending on the valve version and mounting position, the valve, actuator and pipeline must be supported or suspended.

Valves, which are not installed in the pipeline in the upright position with the actuator on top, must be supported or suspended.

Vent plugs

Vent plugs are screwed into the exhaust air ports of pneumatic and electropneumatic devices. They ensure that any exhaust air that forms can be vented to the atmosphere (to avoid excess pressure in the device). Furthermore, the vent plugs allow air intake

Table 5-1: Inlet and outlet lengths

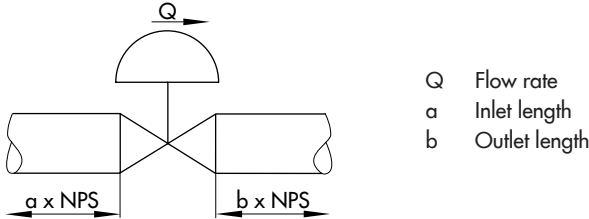

State of process medium	Valve conditions	Inlet length a	Outlet length b
Gas	$Ma \leq 0.3$	2	4
	$0.3 \leq Ma \leq 0.7$	2	10
Vapor	$Ma \leq 0.3$ ¹⁾	2	4
	$0.3 \leq Ma \leq 0.7$ ¹⁾	2	10
	Saturated steam (percentage of condensate > 5 %)	2	20
Liquid	Free of cavitation/ $w < 10$ m/s	2	4
	Cavitation producing noise/ $w \leq 3$ m/s	2	4
	Cavitation producing noise/ $3 < w < 5$ m/s	2	10
	Critical cavitation/ $w \leq 3$ m/s	2	10
	Critical cavitation/ $3 < w < 5$ m/s	2	20
Flashing	–	2	20
Multi-phase	–	10	20

¹⁾ No saturated steam

to prevent a vacuum from forming in the device.

- ➔ Locate the vent plug on the opposite side to the work position of operating personnel.

Valve accessories

- ➔ During connection of valve accessories, make sure that they are easily accessible and can be operated safely from the work position.

5.2 Preparation for installation

Before installation, make sure the following conditions are met:

- The valve is clean.
- The valve and all valve accessories (including piping) are not damaged.
- The valve data on the nameplate (type designation, valve size, material, pressure rating and temperature range) match the plant conditions (size and

- pressure rating of the pipeline, medium temperature etc.). See the 'Markings on the device' section for nameplate details.
- The requested or required additional pipe fittings (see the 'Additional fittings' section) have been installed or prepared as necessary before installing the valve.
- Check any mounted pressure gauges to make sure they function properly.
 - When the valve and actuator are already assembled, check the tightening torques of the bolted joints (▶ AB 0100). Components may loosen during transport.

! NOTICE

Risk of control valve damage due to incorrect insulation.

- Only insulate control valves with insulating section or bellows seal up to the bonnet flange of the valve body for medium temperatures below 0 °C (32 °F) and above 220 °C (428 °F). If the insulating section is insulated, it will not function properly.
- Do not insulate valves mounted to comply with NACE MR0175 requirements and which have nuts and bolts that are not suitable for sour gas environments.

Proceed as follows:

- Lay out the necessary material and tools to have them ready during installation work.
- Flush the pipelines.

i Note

The plant operator is responsible for cleaning the pipelines in the plant.

- For steam applications, dry the pipelines. Moisture will damage the inside of the valve.

5.3 Mounting the device

The activities listed below are necessary to install the valve and before it can be started up.

! NOTICE

Risk of valve damage due to excessively high or low tightening torques.

Observe the specified torques when tightening control valve components. Excessive tightening torques lead to parts wearing out more quickly. Parts that are too loose may cause leakage.

- Observe the specified tightening torques (▶ AB 0100).

! NOTICE

Risk of valve damage due to the use of unsuitable tools.

- Only use tools approved by SAMSON (▶ AB 0100).
-

5.3.1 Mounting the external anti-rotation fixture

Before mounting the actuator, the external anti-rotation fixture must be mounted onto the plug stem in some cases. The valve must be closed beforehand.

For SAMSON Type 3271 and Type 3277 Actuators with Type 3273 Hand-operated Actuator, observe the mounting and operating instructions of the hand-operated actuator (handwheel) to mount the anti-rotation fixture ► EB 8312-X.

a) Standard version for Series 250 Valves, NPS 6 and larger

See Fig. 5-1 and Fig. 5-2

1. Insert ball bearings (310) into the recesses in the bonnet.
2. Place the yoke (3) on the bonnet in such a way that the ball bearings fit into the recesses of the yoke.
3. Fasten the yoke (3) using the castellated nut (92).
4. Fasten the hanger (83) and warning label (255), if applicable, to the yoke using the screws (82).
5. Position the travel indicator scale (84) on the hanger (83) with the screws (85) according to Table 5-4.
6. Use a soft-faced hammer or lever press to press the sliding washers (309) with their beveled part first (without using any lubricant) into the recesses of the clamps

(301) as far as they will go. Remove any excess material.

7. Apply a thin film of lubricant (114) to the threads of the stem (9) and screws (303).

NOTICE

Impaired functioning due to incorrectly applied lubricant.

→ Do not apply any lubricant to the threads of the clamps (301) or the plug stem.

8. Position the clamps (301) and stem (9) on the plug stem according to Table 5-4 and tighten screws (303) and washers (304) by hand.
9. Mount the actuator. See section 5.3.2.
10. Thread the stem (9) upwards until the head of the stem rests on the extended actuator stem.
11. Retract the actuator stem to relieve the stem (9).
12. Gradually tighten the screws (303) in a crisscross pattern. Observe the tightening torques specified in Table 5-2.

Table 5-2: Tightening torques

Screw size	Tightening torque [Nm]
M12	50
M16	121

13. Check and ensure the following:
 - There is a nominal clearance of 0.5 to 1 mm between the sliding washers and their contact surface on the yoke

- on each side (see detailed view Y in Fig. 5-2).
- The anti-rotation fixture does not get stuck on the yoke and can move freely in the direction of travel.
14. Extend the actuator stem again and mount the stem connector clamps.

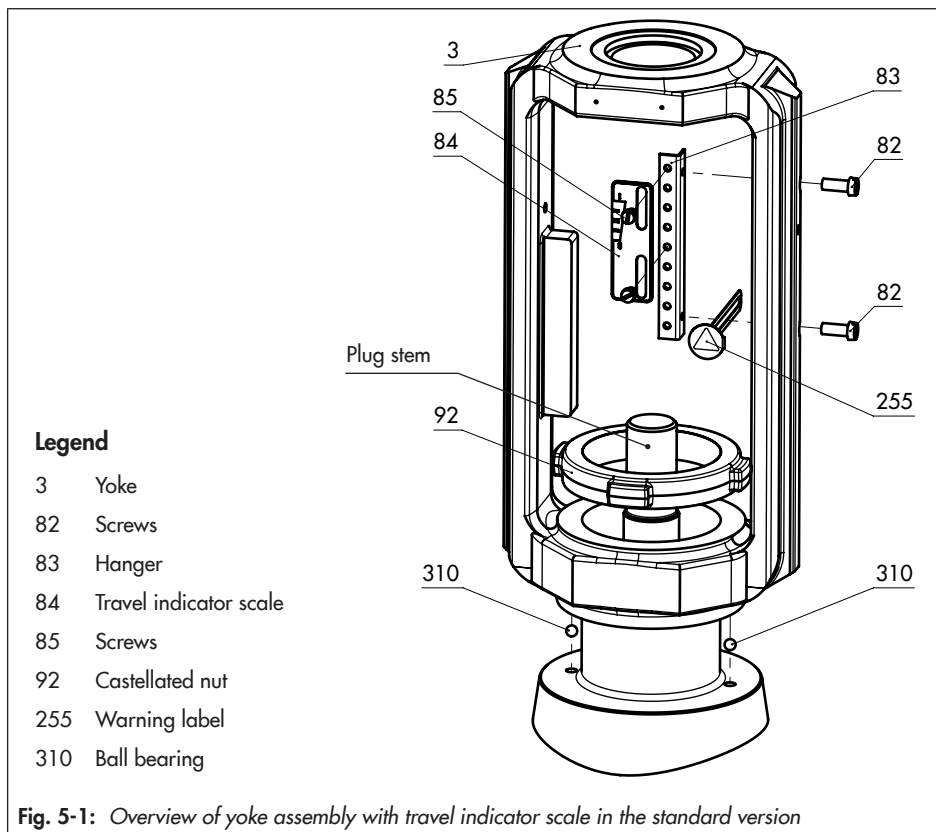

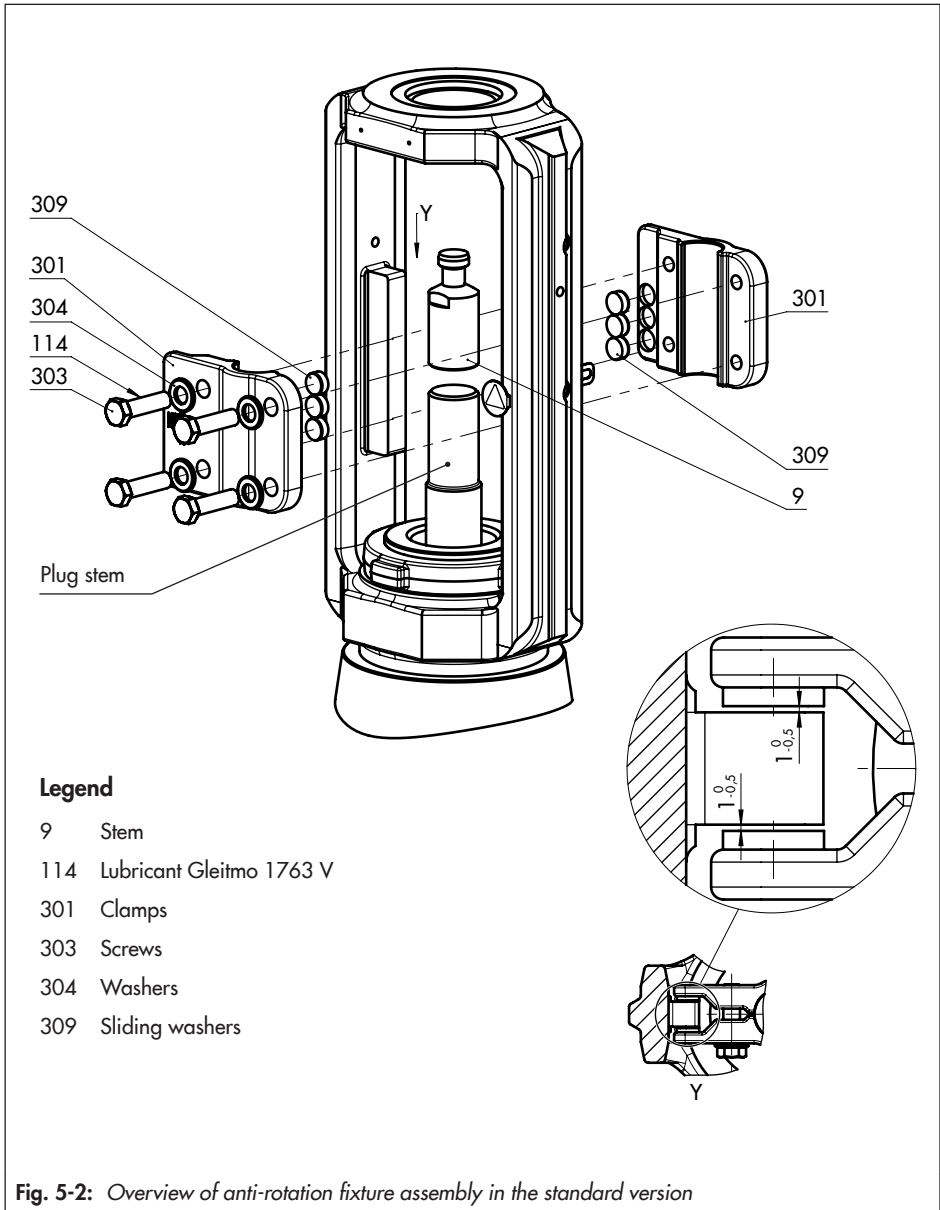

b) Special version for Series 250 Valves, NPS 3 and 4

See Fig. 5-3 and Fig. 5-4

1. Fasten the travel indicator scale (84) with hanger (83) and warning label (255), if applicable, to the yoke using the screws (82). While fastening it, position the travel indicator scale (84) on the hanger (83) according to Table 5-4.
2. Screw tight the holder (302) using the screws (306) and washers (308). Observe the tightening torques specified in Table 5-3.
3. Fasten the yoke (3) using the castellated nut (92).
4. Use a soft-faced hammer or lever press to press the sliding washers (309) (without using any lubricant) into the holes of the clamps (301) as far as they will go. Remove any excess material.
5. Apply a thin film of lubricant (114) to the threads of the stem (9) and screws (303).

NOTICE

Impaired functioning due to incorrectly applied lubricant.

→ Do not apply any lubricant to the threads of the clamps (301) or the plug stem.

6. Position the clamps (301) and stem (9) on the plug stem according to Table 5-4 and tighten screws (303) and washers (304) by hand.
7. Mount the actuator. See section 5.3.2.

8. Thread the stem (9) upwards until the head of the stem rests on the extended actuator stem.
9. Retract the actuator stem to relieve the stem (9).
10. Gradually tighten the screws (303) in a crisscross pattern. Observe the tightening torques specified in Table 5-3.

Table 5-3: Tightening torques

Item	Screw size	Tightening torque [Nm]
306	M10	30
303	M8	15

11. Check and ensure the following:
 - There is a nominal clearance of 0.5 to 1 mm between the sliding washers and their contact surface on the yoke on each side (see detailed view Y in Fig. 5-4).
 - The anti-rotation fixture does not get stuck on the yoke and can move freely in the direction of travel.
12. Extend the actuator stem again and mount the stem connector clamps.

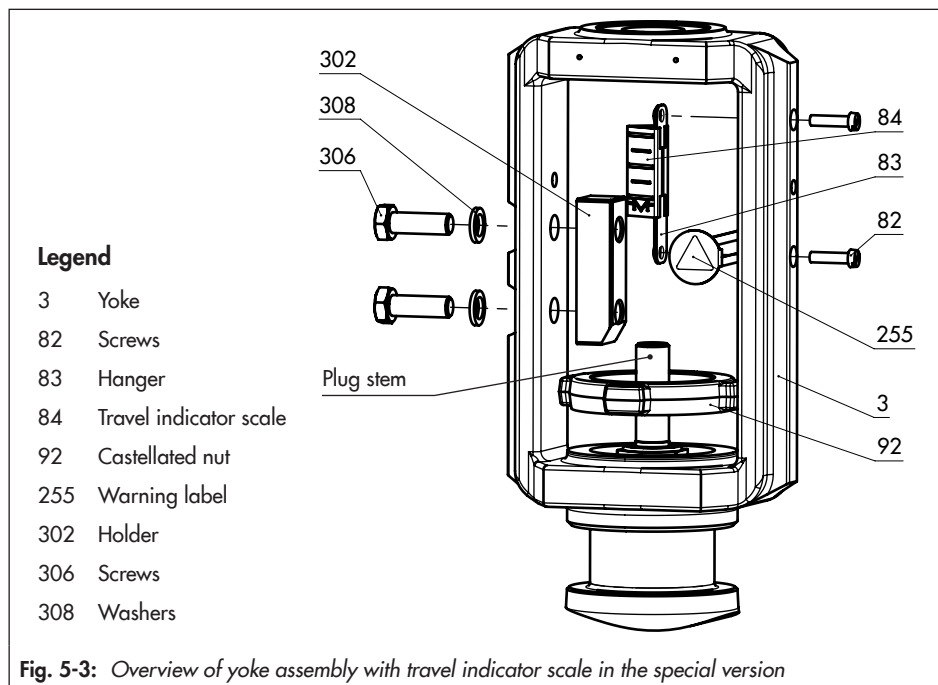

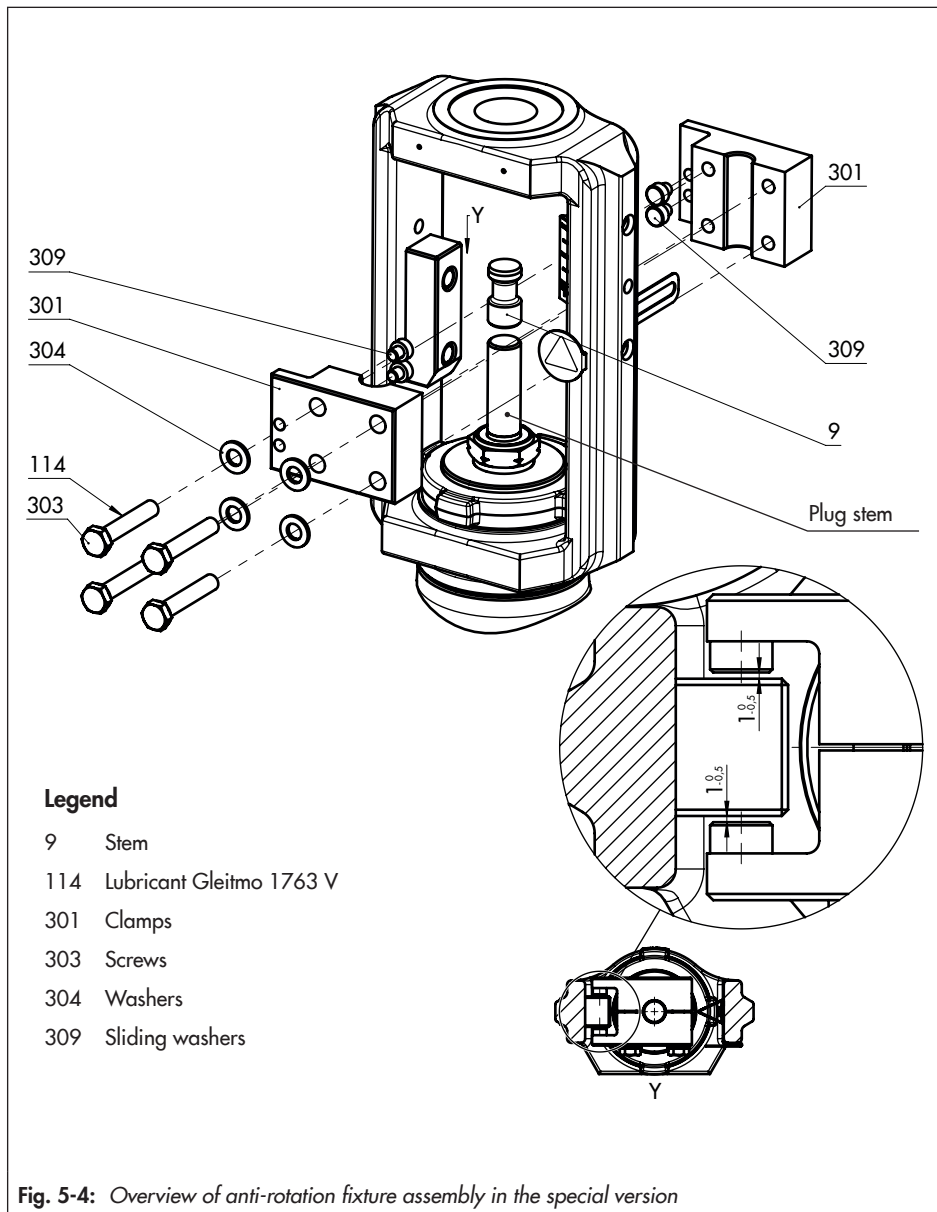

Installation

Table 5-4: Mounting dimensions for Types 3271 and 3277 Pneumatic Actuators · See Fig. 5-5 for dimensional drawing

Actuator [cm ²]	Travel [mm]	Actuator preloading		Dimension when the valve is closed [mm]									
		[%]	[mm]	H _F	H _G	H _I	H _K	H _L	H _N	H _O	H _T		
NPS 3 to 4 · Special version													
350	15	0	0	111	75	192	54	-	66	42	-		
	15	25	3.75	115	71								
355 700 750	15	50	15	111	75								
	15	75	22.5	118.5	67.5								
	30	0	0	96	90							34.5	
	30	25	7.5	103.5	82.5							34.5	
1000 1400-60	15	100	60	136	105			-	-				
	30	75	45	121	120								
1400-120	30	75	90	231	195			-	-				
2800	30	100	120	231	195			-	-				
NPS 6 · Standard version													
355 700 750	15	0	0	263.5	67.5			192	87	48	105	70	145
	15	50	15	256	75	145							
	15	75	22.5	263.5	67.5	145							
	30	0	0	241	90	120							
	30	25	7.5	248.5	82.5	120							
	1000 1400-60	15	100	60	226	105	103						
30		0	0	211	120	88							
30		75	45	211	120	88							
60		0	0	166	165	58							
60		25	15	181	150	58							
1400-120		15	87.5	105	236	180	63						105
	30	0	0	191	225	48	75						
	30	75	90	221	195		105						
	60	0	0	191	225		75						
	60	50	60	191	225		75						
	2800 5600	30	0	0	191		225			75			
30		100	120	221	195		105						
60		0	0	191	225	75							
60		75	90	191	225	75							

Actuator [cm ²]	Travel [mm]	Actuator preloading		Dimension when the valve is closed [mm]												
		[%]	[mm]	H _F	H _G	H _I	H _K	H _L	H _N	H _O	H _T					
NPS 8 to 10 up to seat bore 200 · Standard version																
355 700 750	30	0	0	241	90	195	87	61	108	65	120					
1000 1400-60	30	0	0	211	120						66	83				
	30	75	45	211	120						66	83				
	60	0	0	166	165						52	55				
	60	25	15	181	150						52	55				
1400-120	15	87.5	105	236	180						61	115				
	30	0	0	191	225						48	76				
	30	75	90	221	195						61	100				
	60	0	0	308	255						61	185				
	60	50	60	191	225						48	76				
2800 5600	30	0	0	191	225						48	76				
	30	100	120	221	195						61	100				
	60	0	0	308	255						61	185				
	60	75	90	191	225						48	76				
NPS 10, seat bore 250 and NPS 12 to 20 · Standard version																
1000 1400-60	30	0	0	281	135						237	87	100	150	110	121
	30	75	45	296	120	135										
	60	0	0	251	165	91										
	60	25	15	266	150	91										
1400-120	60	0	0	308	255	145										
	60	50	60	338	225	175										
	120	0	0	278	285	FA ¹⁾ = 115 FE ²⁾ = 86										
2800 5600	60	0	0	308	255	145										
	60	75	90	338	225	175										
	120	0	0	248	315	FE ²⁾ = 86										
	120	25	30	278	285	115										

1) FA = Actuator stem extends (fail-close)

2) FE = Actuator stem retracts (fail-open)

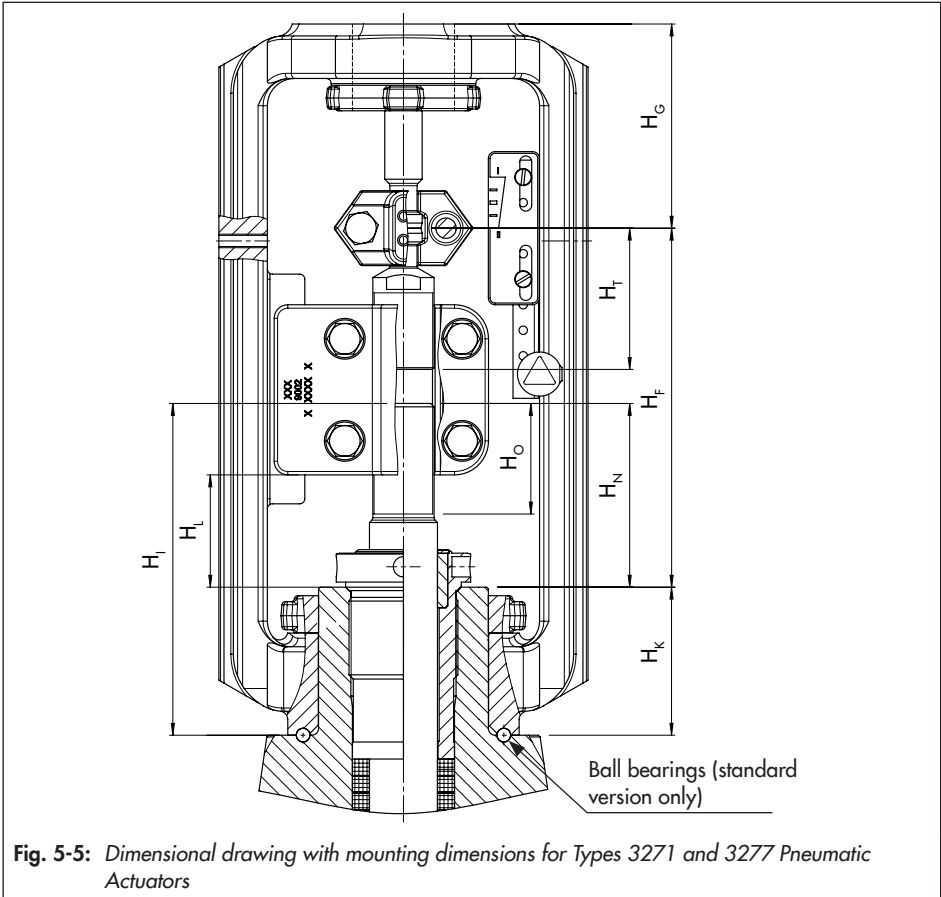

Fig. 5-5: Dimensional drawing with mounting dimensions for Types 3271 and 3277 Pneumatic Actuators

5.3.2 Mounting the actuator onto the valve

⚠ WARNING

Risk of personal injury due to preloaded springs.

Actuators with preloaded springs are under tension. They can be identified by the long bolts protruding from the bottom of the actuator.

- Before starting any work on the actuator, relieve the compression from the preloaded springs (see associated actuator documentation).

⚠ WARNING

Risk of personal injury due to incorrect removal of the anti-rotation fixture under tension.

Once the actuator has been mounted on the valve and the assembly is ready for use, the clamps (301) of the anti-rotation fixture on the plug stem are under tension.

- Follow the instructions in this document during mounting or removal.
- Do not loosen the screws (303) of the anti-rotation fixture while the force generated by the supply air and/or the actuator springs is transmitted to the actuator stem and the stem (9).
- First remove the actuator from the valve or ensure it cannot transmit any forces to the actuator stem before removing the anti-rotation fixture on the plug stem.

Depending on the version, SAMSON control valves are either delivered with the actuator already mounted on the valve or the valve and actuator are delivered separately. When delivered separately, the valve and actuator must be assembled together on site.

Versions with V-port plug

To achieve the best flow conditions inside the valve, the V-port plug must always be installed with the port that releases the flow first when the valve opens facing toward the valve outlet. This is the largest of the three V-shaped ports (see Fig. 5-6).

- Before mounting the actuator, determine which V-shaped port is uncovered first when the plug is lifted out of the seat.
- On mounting the actuator, make sure that the V-shaped port uncovered first faces toward the valve outlet.

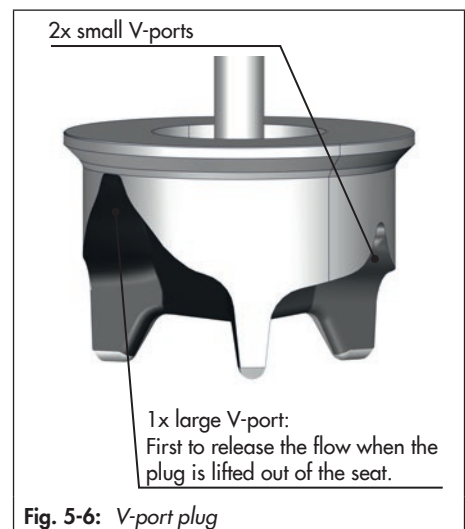

Fig. 5-6: V-port plug

Versions with perforated plug

Only one hole is located near the seal facing of perforated plugs with equal percentage characteristic. Depending on the valve size, the hole pattern varies and is partly unsymmetrical. The process medium in the valve flows through the holes as soon as the plug is lifted out of the seat. To achieve the best flow conditions inside the valve, the perforated plug must always be installed with the hole that releases the flow first when the valve opens facing toward the valve outlet (see Fig. 5-7).

- Before mounting the actuator, check the hole pattern of the perforated plug and determine which hole is the closest to the seal facing and is uncovered first when the plug is lifted out of the seat.
- On mounting the actuator, make sure that the hole uncovered first faces toward the valve outlet.

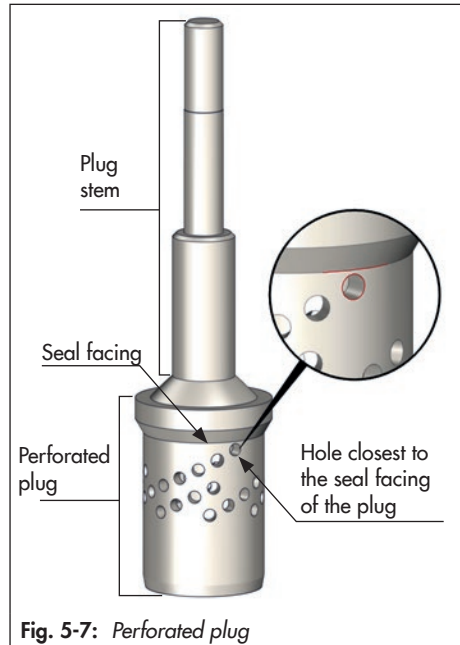

Fig. 5-7: Perforated plug

a) Mounting the actuator

- To mount the actuator, proceed as described in the associated actuator documentation.

b) Aligning the travel indicator scale

After mounting the actuator, the travel indicator scale must be aligned. To do so, align '0' on the travel indicator scale with the tip of the stem connector clamp (see Fig. 5-5).

1. Move the valve to the closed position.
2. Loosen the screws on the travel indicator scale.

3. Align the travel indicator scale.
4. Fix the travel indicator scale into place by tightening the screws.

5.3.3 Installing the valve into the pipeline

ⓘ NOTICE

Risk of valve damage due to work being carried out by personnel not qualified for such tasks.

The plant operator or specialist company performing the welding is responsible for the selection of the welding procedure and the actual welding operations on the valve. This also applies to any required heat treatment to be performed on the valve.

→ *Only allow qualified welding personnel to carry out welding operations.*

ⓘ NOTICE

Premature wear and leakage due to insufficient support or suspension.

→ *Support or suspend the valve sufficiently at suitable points.*

4. Lift the valve using suitable lifting equipment to the site of installation (see the 'Lifting the valve' section). Observe the flow direction through the valve. The arrow on the valve indicates the direction of flow.
5. Make sure that the correct flange gaskets are used.
6. Bolt the pipe to the valve free of stress.
7. Attach a support or suspension on the valve, if necessary.

b) Version with welding ends

1. Proceed as described above under 'Version with flanges', steps 1 to 4.
2. Completely retract the actuator stem to protect the plug from sparks during welding.
3. Weld the valve free of stress into the pipeline.
4. Attach a support or suspension on the valve, if necessary.

a) Version with flanges

1. Close the shut-off valves in the pipeline at the inlet and outlet of the plant section while the valve is being installed.
2. Prepare the relevant section of the pipeline for installing the valve.
3. Remove the protective caps from the valve ports before installing the valve.

5.4 Testing the installed valve

⚠ DANGER

Risk of bursting due to incorrect opening of pressurized equipment or components.

Valves and pipelines are pressure equipment that may burst when handled incorrectly. Flying projectile fragments or the release of process medium under pressure can cause serious injury or even death.

Before working on the control valve:

- Depressurize all plant sections affected and the valve (including the actuator). Release any stored energy.
- Drain the process medium from all the plant sections concerned as well as the valve.

⚠ WARNING

Risk of personal injury due to pressurized components and process medium being discharged.

- Do not loosen the screw of the test connection while the valve is pressurized.

⚠ WARNING

Risk of hearing loss or deafness due to loud noise.

Noise emission (e.g. cavitation or flashing) may occur during operation caused by the process medium and the operating conditions. Additionally, a loud noise may briefly occur through the sudden venting of the pneumatic actuator or pneumatic valve accessories not fitted with noise-reducing fittings. Both can damage hearing.

- Wear hearing protection when working near the valve.

⚠ WARNING

Crush hazard arising from actuator and plug stem moving.

- Do not insert hands or finger into the yoke while the air supply is connected to the actuator.
- Before working on the control valve, disconnect and lock the pneumatic air supply as well as the control signal.
- Do not impede the movement of the actuator and plug stem by inserting objects into the yoke.
- Before unblocking the actuator and plug stem after they have become blocked (e.g. due to seizing up after remaining in the same position for a long time), release any stored energy in the actuator (e.g. spring compression). See associated actuator documentation.

⚠ WARNING

Risk of personal injury due to exhaust air being vented.

While the valve is operating, air is vented from the actuator, for example, during closed-loop operation or when the valve opens or closes.

- Wear eye protection when working in close proximity to the control valve.

⚠ WARNING***Risk of personal injury due to preloaded springs.***

Actuators with preloaded springs are under tension. They can be identified by the long bolts protruding from the bottom of the actuator.

➔ *Before starting any work on the actuator, relieve the compression from the preloaded springs (see associated actuator documentation).*

To test the valve functioning before start-up or putting back the valve into operation, perform the following tests:

5.4.1 Leak test

The plant operator is responsible for performing the leak test and selecting the test method. The leak test must comply with the requirements of the national and international standards that apply at the site of installation.

**Tip**

Our after-sales service can support you to plan and perform a leak test for your plant.

1. Close the valve.
2. Slowly apply the test medium to the inlet space upstream of the valve. A sudden surge in pressure and resulting high flow velocities can damage the valve.
3. Open the valve.
4. Apply the required test pressure.

5. Check the valve for leakage to the atmosphere.
6. Depressurize the pipeline section and valve.
7. Rework any parts that leak (see information below under 'Adjusting the packing') and repeat the leak test.

Adjusting the packing

A label on the flange or yoke indicates whether an adjustable packing is installed (see the 'Markings on the device' section).

⚠ NOTICE***Impaired valve functioning due to increased friction as a result of the threaded bushing being tightened too far.***

➔ *Make sure that the plug stem can still move smoothly after the threaded bushing has been tightened.*

1. Tighten the threaded bushing gradually (by turning it clockwise) until the packing seals the valve.
 2. Open and close the valve several times.
 3. Check the valve for leakage to the atmosphere.
 4. Repeat steps 1 and 2 until the packing completely seals the valve.
- ➔ If the adjustable packing does not seal properly, contact our after-sales service.

5.4.2 Travel motion

The movement of the actuator stem must be linear and smooth.

Installation

- Apply the maximum and minimum control signals to check the end positions of the valve while observing the movement of the actuator stem.
- Check the travel reading at the travel indicator scale.

5.4.3 Fail-safe position

- Shut off the signal pressure line.
- Check whether the valve moves to the fail-safe position (see the 'Design and principle of operation' section).

5.4.4 Pressure test

The plant operator is responsible for performing the pressure test.



Tip

Our after-sales service can support you to plan and perform a pressure test for your plant.

During the pressure test, make sure the following conditions are met:

- Retract the plug stem to open the valve.
- Observe the maximum permissible pressure for both the valve and plant.

6 Start-up

The work described in this section is only to be performed by personnel appropriately qualified to carry out such tasks.

⚠ WARNING

Risk of burn injuries due to hot or cold components and pipeline.

Valve components and the pipeline may become very hot or cold. Risk of burn injuries.

- Allow components and pipelines to cool down or warm up to the ambient temperature.
- Wear protective clothing and safety gloves.

⚠ WARNING

Risk of personal injury due to pressurized components and process medium being discharged.

- Do not loosen the screw of the test connection while the valve is pressurized.

⚠ WARNING

Risk of hearing loss or deafness due to loud noise.

Noise emission (e.g. cavitation or flashing) may occur during operation caused by the process medium and the operating conditions. Additionally, a brief loud noise may occur through the sudden venting of the pneumatic actuator (see 'Fail-safe position') or pneumatic valve accessories not fitted with noise-reducing fittings. Both can damage hearing.

- Wear hearing protection when working near the valve.

⚠ WARNING

Crush hazard arising from actuator and plug stem moving.

- Do not insert hands or finger into the yoke while the air supply is connected to the actuator.
- Before working on the control valve, disconnect and lock the pneumatic air supply as well as the control signal.
- Do not impede the movement of the actuator and plug stem by inserting objects into the yoke.
- Before unblocking the actuator and plug stem after they have become blocked (e.g. due to seizing up after remaining in the same position for a long time), release any stored energy in the actuator (e.g. spring compression). See associated actuator documentation.

⚠ WARNING

Risk of personal injury due to exhaust air being vented.

While the valve is operating, air is vented from the actuator, for example, during closed-loop operation or when the valve opens or closes.

- Wear eye protection when working in close proximity to the control valve.

Start-up

Before start-up or putting the valve back into service, make sure the following conditions are met:

- The valve is properly installed into the pipeline (see the 'Installation' section).
- The leak and function tests have been completed successfully (see the 'Testing the installed valve' section).
- The prevailing conditions in the plant section concerned meet the valve sizing requirements (see information under 'Intended use' in the 'Safety instructions and measures' section).

Start-up/putting the valve back into operation

1. Allow the valve to cool down or warm up to reach ambient temperature before start-up when the ambient temperature and process medium temperature differ greatly or the medium properties require such a measure.
2. Slowly open the shut-off valves in the pipeline. Slowly opening these valves prevents a sudden surge in pressure and high flow velocities which can damage the valve.
3. Check the valve to ensure it functions properly.

7 Operation

Immediately after completing start-up or putting the valve back into operation (see the 'Start-up' section), the valve is ready for use.

⚠ WARNING

Risk of burn injuries due to hot or cold components and pipeline.

Valve components and the pipeline may become very hot or cold. Risk of burn injuries.

- Allow components and pipelines to cool down or warm up to the ambient temperature.
- Wear protective clothing and safety gloves.

⚠ WARNING

Risk of personal injury due to pressurized components and process medium being discharged.

- Do not loosen the screw of the test connection while the valve is pressurized.

⚠ WARNING

Risk of hearing loss or deafness due to loud noise.

Noise emission (e.g. cavitation or flashing) may occur during operation caused by the process medium and the operating conditions. Additionally, a loud noise may briefly occur through the sudden venting of the pneumatic actuator or pneumatic valve accessories not fitted with noise-reducing fittings. Both can damage hearing.

- Wear hearing protection when working near the valve.

⚠ WARNING

Crush hazard arising from actuator and plug stem moving.

- Do not insert hands or finger into the yoke while the air supply is connected to the actuator.
- Before working on the control valve, disconnect and lock the pneumatic air supply as well as the control signal.
- Do not impede the movement of the actuator and plug stem by inserting objects into the yoke.
- Before unblocking the actuator and plug stem after they have become blocked (e.g. due to seizing up after remaining in the same position for a long time), release any stored energy in the actuator (e.g. spring compression). See associated actuator documentation.

⚠ WARNING

Risk of personal injury due to exhaust air being vented.

While the valve is operating, air is vented from the actuator, for example, during closed-loop operation or when the valve opens or closes.

- Wear eye protection when working in close proximity to the control valve.

Operation

7.1 Normal operation

The handwheel of valves with actuators fitted with a handwheel must be in the neutral position during normal operation.

7.2 Manual operation

Valves with actuators fitted with a handwheel can be manually closed or opened in case of supply air failure.

8 Malfunctions

Read hazard statements, warnings and caution notes in the 'Safety instructions and measures' section.

8.1 Troubleshooting

Malfunction	Possible reasons	Recommended action
Actuator and plug stem does not move on demand.	Actuator is blocked.	Check attachment. Remove the blockage. WARNING! A blocked actuator or plug stem (e.g. due to seizing up after remaining in the same position for a long time) can suddenly start to move uncontrollably. Injury to hands or fingers is possible if they are inserted into the actuator or valve. Before trying to unblock the actuator or plug stem, disconnect and lock the pneumatic air supply as well as the control signal. Before unblocking the actuator, release any stored energy in the actuator (e.g. spring compression). See associated actuator documentation.
	Diaphragm in the actuator defective	See associated actuator documentation.
	Signal pressure too low	Check the signal pressure. Check the signal pressure line for leakage.
Jolting movement of the actuator and plug stem	Version with adjustable packing ¹⁾ ; packing not tightened correctly	Tighten the packing correctly (see information under 'Adjusting the packing' in the 'Installation' section > 'Testing the installed valve').
Actuator and plug stem does not stroke through the entire range.	Signal pressure too low	Check the signal pressure. Check the signal pressure line for leakage.
	Travel stop active	See associated actuator documentation.
	Incorrect setting of valve accessories	Check the settings of the valve accessories.
Increased flow through closed valve (seat leakage)	Dirt or other foreign particles deposited between the seat and plug.	Shut off the section of the pipeline and flush the valve.
	Valve trim, particularly with soft seat, is worn.	Replace seat and plug (see the 'Servicing' section) or contact our after-sales service.

Malfunctions

Malfunction	Possible reasons	Recommended action
The valve leaks to the atmosphere (fugitive emissions).	Defective packing	Replace packing (see the 'Servicing' section) or contact our after-sales service.
	Version with adjustable packing ¹⁾ : packing not tightened correctly	Adjust the packing (see information under 'Adjusting the packing' in the 'Installation' section > 'Testing the installed valve'). Contact our after-sales service when it continues to leak.
	Version with bellows seal: the bellows seal is defective.	Contact our after-sales service.
	Flange joint loose or gasket worn out	Check the flange joint. Replace gasket at the flanged joint (see the 'Servicing' section) or contact our after-sales service.

¹⁾ See the 'Markings on the device' section.

i Note

Contact our after-sales service for malfunctions not listed in the table.

8.2 Emergency action

Plant operators are responsible for emergency action to be taken in the plant.

In the event of a valve malfunction:

1. Close the shut-off valves upstream and downstream of the control valve to stop the process medium from flowing through the valve.
2. Perform troubleshooting (see section 8.1).

3. Rectify those malfunctions that can be remedied based on the instructions provided here. Contact our after-sales service in all other cases.

Putting the valve back into operation after a malfunction

See the 'Start-up' section.

9 Servicing

The work described in this section is only to be performed by personnel appropriately qualified to carry out such tasks.

The following documents are also required for servicing the valve:

- Mounting and operating instructions for the mounted actuator, e.g. ► EB 8310-X for Type 3271 or Type 3277 Pneumatic Actuator
- ► AB 0100 for tools, tightening torques and lubricant

! DANGER

Risk of bursting due to incorrect opening of pressurized equipment or components.

Valves and pipelines are pressure equipment that may burst when handled incorrectly. Flying projectile fragments or the release of process medium under pressure can cause serious injury or even death.

Before working on the control valve:

- Depressurize all plant sections affected and the valve (including the actuator). Release any stored energy.
- Drain the process medium from all the plant sections concerned as well as the valve.

! WARNING

Risk of burn injuries due to hot or cold components and pipeline.

Valve components and the pipeline may become very hot or cold. Risk of burn injuries.

- Allow components and pipelines to cool down or warm up to the ambient temperature.
- Wear protective clothing and safety gloves.

! WARNING

Risk of personal injury due to pressurized components and process medium being discharged.

- Do not loosen the screw of the test connection while the valve is pressurized.

! WARNING

Risk of hearing loss or deafness due to loud noise.

Noise emission (e.g. cavitation or flashing) may occur during operation caused by the process medium and the operating conditions. Additionally, a loud noise may briefly occur through the sudden venting of the pneumatic actuator or pneumatic valve accessories not fitted with noise-reducing fittings. Both can damage hearing.

- Wear hearing protection when working near the valve.

! WARNING

Crush hazard arising from actuator and plug stem moving.

- Do not insert hands or finger into the yoke while the air supply is connected to the actuator.

Servicing

- Before working on the control valve, disconnect and lock the pneumatic air supply as well as the control signal.
- Do not impede the movement of the actuator and plug stem by inserting objects into the yoke.
- Before unblocking the actuator and plug stem after they have become blocked (e.g. due to seizing up after remaining in the same position for a long time), release any stored energy in the actuator (e.g. spring compression). See associated actuator documentation.

⚠ WARNING

Risk of personal injury due to exhaust air being vented.

While the valve is operating, air is vented from the actuator, for example, during closed-loop operation or when the valve opens or closes.

- Wear eye protection when working in close proximity to the control valve.

⚠ WARNING

Risk of personal injury due to preloaded springs.

Actuators with preloaded springs are under tension. They can be identified by the long bolts protruding from the bottom of the actuator.

- Before starting any work on the actuator, relieve the compression from the preloaded springs (see associated actuator documentation).

⚠ WARNING

Risk of personal injury due to residual process medium in the valve.

While working on the valve, residual medium can flow out of the valve and, depending on its properties, cause personal injury, e.g. (chemical) burns.

- Wear protective clothing, safety gloves, respiratory protection and eye protection.

ⓘ NOTICE

Risk of valve damage due to excessively high or low tightening torques.

Observe the specified torques when tightening control valve components. Excessive tightening torques lead to parts wearing out more quickly. Parts that are too loose may cause leakage.

- Observe the specified tightening torques (▶ AB 0100).

ⓘ NOTICE

Risk of valve damage due to the use of unsuitable tools.

- Only use tools approved by SAMSON (▶ AB 0100).

ⓘ NOTICE

Risk of valve damage due to the use of unsuitable lubricants.

- Only use lubricants approved by SAMSON (▶ AB 0100).

i Note

The control valve was checked by SAMSON before it left the factory.

- Certain test results certified by SAMSON lose their validity when the valve is opened. Such testing includes seat leakage and leak tests.
- The product warranty becomes void if service or repair work not described in these instructions is performed without prior agreement by SAMSON's After-sales Service.
- Only use original spare parts by SAMSON, which comply with the original specifications.

9.1 Periodic testing

Depending on the operating conditions, check the valve at certain intervals to prevent possible failure before it can occur. Plant operators are responsible for drawing up an inspection and test plan.

 **Tip**

Our after-sales service can support you in drawing up an inspection and test plan for your plant.

We recommend the following inspection and testing which can be performed while the process is running:

Inspection and testing	Action to be taken in the event of a negative result:
Check the markings, labels and nameplates on the valve for their readability and completeness.	Immediately renew damaged, missing or incorrect nameplates or labels.
	Clean any inscriptions that are covered with dirt and are illegible.
Check the pipe connections and gaskets on the valve and actuator for leakage.	Check the bolted joint (tightening torque).
	Replace the gasket on the flanged joint as described in section 9.4.1 and section 9.4.2.
	Version with adjustable packing ¹⁾ : tighten the packing (see information under 'Adjusting the packing' in the 'Installation' section > 'Testing the installed valve'). If the packing leaks continuously, replace the packing (see section 9.4.3).

Servicing

Inspection and testing	Action to be taken in the event of a negative result:
<p>Check the test connection and bellows seal (if used) for external leakage. WARNING! Risk of personal injury due to pressurized components and process medium being discharged. Do not loosen the screw of the test connection while the valve is pressurized.</p>	<p>Put the control valve out of operation (see the 'Decommissioning' section). To repair the bellows seal, contact our after-sales service (see the 'Repairs' section).</p>
<p>Check the valve's seat leakage.</p>	<p>Shut off the section of the pipeline and flush the valve to remove any dirt and/or deposited foreign particles between the seat and plug. Replace the seat and plug (see section 9.4.4)</p>
<p>Check the valve for external damage (e.g. corrosion).</p>	<p>Repair any damage immediately. If necessary, put the control valve out of operation (see the 'Decommissioning' section).</p>
<p>Check the valve accessories to ensure they are mounted properly.</p>	<p>Tighten the connections of the valve accessories.</p>
<p>Check to ensure that the actuator and plug stem move smoothly.</p>	<p>Version with adjustable packing ¹⁾: tighten the packing correctly (see information under 'Adjusting the packing' in the 'Installation' section > 'Testing the installed valve'). Unblock a blocked actuator and plug stem. WARNING! A blocked actuator or plug stem (e.g. due to seizing up after remaining in the same position for a long time) can suddenly start to move uncontrollably. Injury to hands or fingers is possible if they are inserted into the actuator or valve. Before trying to unblock the actuator or plug stem, disconnect and lock the pneumatic air supply as well as the control signal. Before unblocking the actuator, release any stored energy in the actuator (e.g. spring compression). See associated actuator documentation.</p>
<p>If possible, check the valve's fail-safe position by briefly interrupting the air supply.</p>	<p>Put the control valve out of operation (see the 'Decommissioning' section). Identify the cause for the malfunction and rectify it (see the 'Troubleshooting' section).</p>

¹⁾ See the 'Markings on the device' section

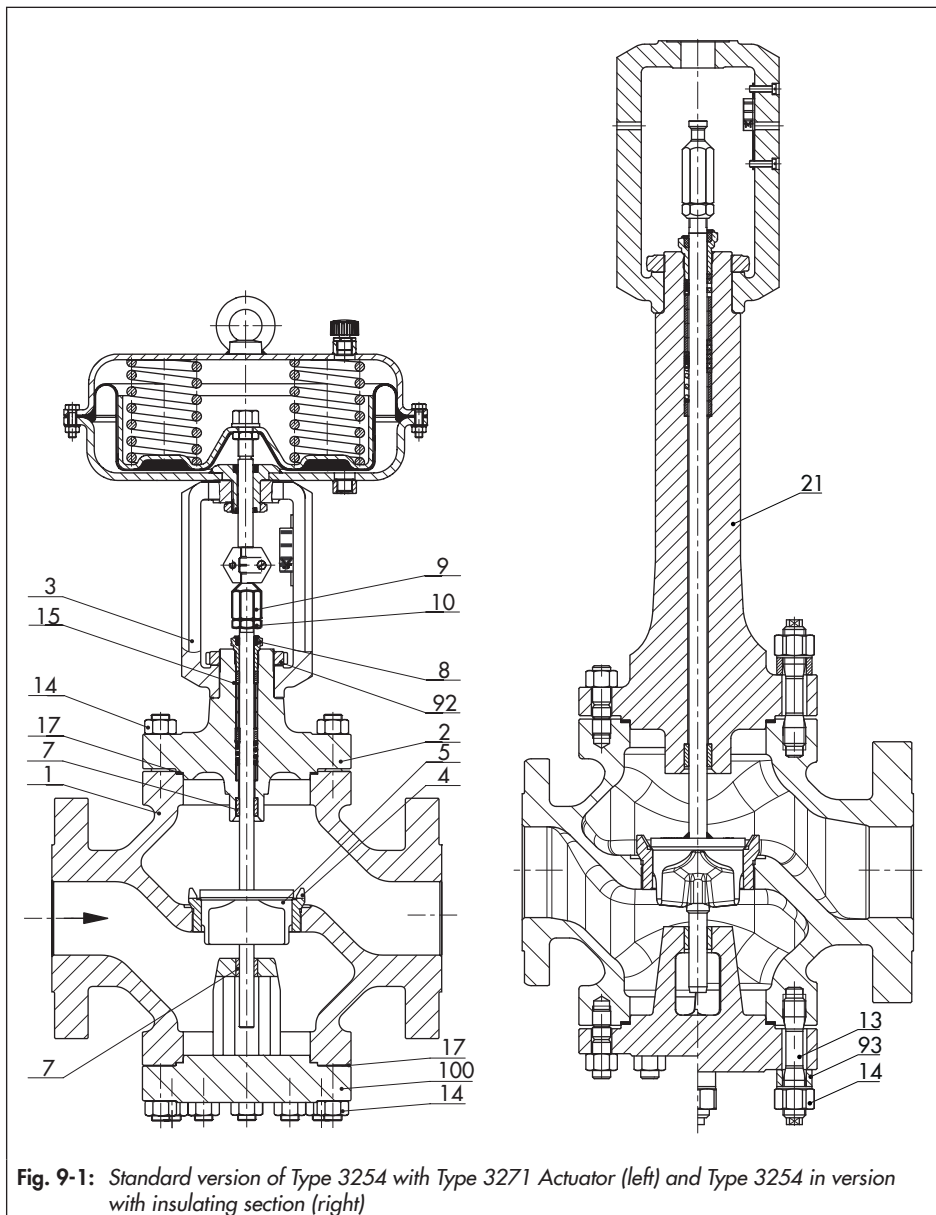

Fig. 9-1: Standard version of Type 3254 with Type 3271 Actuator (left) and Type 3254 in version with insulating section (right)

Legend for Fig. 9-1

1	Body	13	Stud bolt
2	Bonnet	14	Nut
3	Yoke	15	Packing
4	Seat	17	Body gasket
5	Plug (with plug stem)	21	Insulating section
7	Guide bushing	92	Castellated nut
8	Threaded bushing (packing nut)	93	Expansion sleeve (for Class 150 to 2500)
9	Stem connector nut	100	Flange
10	Lock nut		

9.2 Preparing the valve for service work

WARNING

Risk of personal injury due to incorrect removal of the anti-rotation fixture under tension.

Once the actuator has been mounted on the valve and the assembly is ready for use, the clamps (301) of the anti-rotation fixture on the plug stem are under tension.

- ➔ Follow the instructions in this document during mounting or removal.
- ➔ Do not loosen the screws (303) of the anti-rotation fixture while the force generated by the supply air and/or the actuator springs is transmitted to the actuator stem and the stem (9).
- ➔ First remove the actuator from the valve or ensure it cannot transmit any forces to the actuator stem before removing the anti-rotation fixture on the plug stem.

1. Lay out the necessary material and tools to have them ready for the service work.

2. Put the control valve out of operation (see the 'Decommissioning' section).
3. Remove the actuator from the valve. See associated actuator documentation.

Note

To remove an actuator with "stem extends" fail-safe action and/or with preloaded springs, a certain signal pressure must be applied to the actuator (see associated actuator documentation). Afterwards, the signal pressure must be removed and the air supply disconnected again and locked.

Tip

We recommend removing the valve from the pipeline before performing any service work (see the 'Removing the valve from the pipeline' section).

The following service work can be performed after preparation is completed:

- Replace the top gasket as described in section 9.4.1.

- Replace the bottom gasket as described in section 9.4.2.
- Replace the packing (see section 9.4.3)
- Replace the seat and plug (see section 9.4.4)

9.3 Installing the valve after service work

1. Mount actuator. See associated actuator documentation and the 'Installation' section.
2. Adjust lower or upper signal bench range. See associated actuator documentation.
3. If the valve has been removed, re-install the valve into the pipeline (see the 'Installation' section).
4. Put the control valve back into operation (see the 'Start-up' section). Observe the requirements and conditions for start-up or putting the valve back into operation.

9.4 Service work

- Before performing any service work, preparations must be made to the control valve (see section 9.2).
- After all service work is completed, check the control valve before putting it back into operation (see 'Testing the installed valve' in the 'Installation' section).

9.4.1 Replacing the top gasket

! NOTICE

Risk of control valve damage due to incorrect servicing.

- *The gasket can only be replaced when all the following conditions are met:*
 - *The valve size is \leq NPS 4.*
 - *The valve does not have a balanced plug.*
 - *The valve does not have a flow divider.*
- *To replace the gasket in other valve versions, contact our after-sales service.*

a) Standard version

1. Undo the top body nuts (14) gradually in a crisscross pattern.
2. Lift the bonnet (2) and plug with plug stem (5) off the body (1).
3. Remove the top gasket (17). Carefully clean the sealing faces in the valve body (1) and on the bonnet (2).
4. Insert a new gasket (17) into the body.
5. Place the bonnet (2) onto the body.

Version with V-port plug: place the bonnet (2) onto the valve body, making sure that the largest V-shaped part of the V-port plug faces towards the valve outlet.

Version with perforated plug: place the bonnet (2) onto the valve body, making sure that the hole of the plug that releases the flow first faces toward the valve outlet.

Servicing

See relevant information under 'Mounting the actuator onto the valve' in the 'Installation' section.

6. Firmly press the plug (5) into the seat (4). Fasten down the bonnet (2) with the top body nuts (14). Tighten the nuts gradually in a crisscross pattern. Observe tightening torques.

b) Version with insulating section or bellows seal

1. Undo the top body nuts (14) gradually in a crisscross pattern.
2. Lift the insulating section (21) and plug with plug stem (5) off the body (1).
3. Remove the top gasket (17). Carefully clean the sealing faces in the valve body (1) and on the insulating section (21).
4. Insert a new gasket (17) into the body.
5. Place the insulating section (21) onto the body.

Version with V-port plug: place the insulating section (21) onto the valve body, making sure that the largest V-shaped port of the V-port plug faces towards the valve outlet.

Version with perforated plug: place the insulating section (21) onto the insulating section, making sure that the hole of the plug that releases the flow first faces toward the valve outlet.

See relevant information under 'Mounting the actuator onto the valve' in the 'Installation' section.

6. Firmly press the plug (5) into the seat (4). Fasten down the insulating section (21) with the top body nuts (14). Tighten the nuts gradually in a crisscross pattern. Observe tightening torques.

9.4.2 Replacing the bottom gasket

NOTICE

Risk of control valve damage due to incorrect servicing.

- *The gasket can only be replaced when all the following conditions are met:*
- *The valve size is \leq NPS 4.*
 - *The valve does not have a balanced plug.*
 - *The valve does not have a flow divider.*
- *To replace the gasket in other valve versions, contact our after-sales service.*
-

1. Undo the bottom body nuts (14) gradually in a crisscross pattern.
2. Remove the flange (100) from the body (1).
3. Remove the bottom gasket (17). Carefully clean the sealing faces in the valve body (1) and on the flange (100).
4. Make sure that the top guide bushing (7) is not damaged. If necessary, replace the guide bushing using a suitable tool.
5. Insert a new gasket (17) into the flange.
6. Place the flange (100) onto the body. Make sure that the plug stem (5) is properly seated in the guide.

7. Fasten down the flange with the bottom body nuts (14). Tighten the nuts gradually in a crisscross pattern. Observe tightening torques.

9.4.3 Replacing the packing

ⓘ NOTICE

Risk of control valve damage due to incorrect servicing.

- *The packing can only be replaced when all the following conditions are met:*
- *The valve size is \leq NPS 4.*
 - *The valve does not have a balanced plug.*
 - *The valve does not have a bellows seal.*
 - *The standard or ADSEAL packing is installed in the valve.*
- *To replace the packing in other valve versions, contact our after-sales service.*

6. Pull the plug with plug stem (5) out of the bonnet (2).
7. Pull the entire packing out of the packing chamber using a suitable tool.
8. Renew damaged parts. Clean the packing chamber thoroughly.
9. Apply a suitable lubricant to all the packing parts and to the plug stem (5).
10. Slide the plug with plug stem (5) into the bonnet (2).
11. Place the bonnet (2) together with the plug stem and plug (5) onto the body.

Version with V-port plug: place the bonnet (2) onto the valve body, making sure that the largest V-shaped part of the V-port plug faces towards the valve outlet.

Version with perforated plug: place the bonnet (2) onto the valve body, making sure that the hole of the plug that releases the flow first faces toward the valve outlet.

See relevant information under 'Mounting the actuator onto the valve' in the 'Installation' section.

a) Standard version

Standard packing (PTFE)

1. Unscrew the castellated nut (92) and lift the yoke (3) off the bonnet (2).
2. Undo the top body nuts (14) gradually in a crisscross pattern.
3. Lift the bonnet (2) and plug with plug stem (5) off the body (1).
4. Unscrew the stem connector nut (9) and lock nut (10) from the plug stem.
5. Unscrew the threaded bushing (8).
6. Pull the plug with plug stem (5) out of the bonnet (2).
7. Pull the entire packing out of the packing chamber using a suitable tool.
8. Renew damaged parts. Clean the packing chamber thoroughly.
9. Apply a suitable lubricant to all the packing parts and to the plug stem (5).
10. Slide the plug with plug stem (5) into the bonnet (2).
11. Place the bonnet (2) together with the plug stem and plug (5) onto the body.
12. Carefully slide the packing parts over the plug stem into the packing chamber using a suitable tool. Observe the proper sequence (see Fig. 9-2).
13. Firmly press the plug (5) into the seat (4). Fasten down the bonnet (2) with the top body nuts (14). Tighten the nuts gradually in a crisscross pattern. Observe tightening torques.

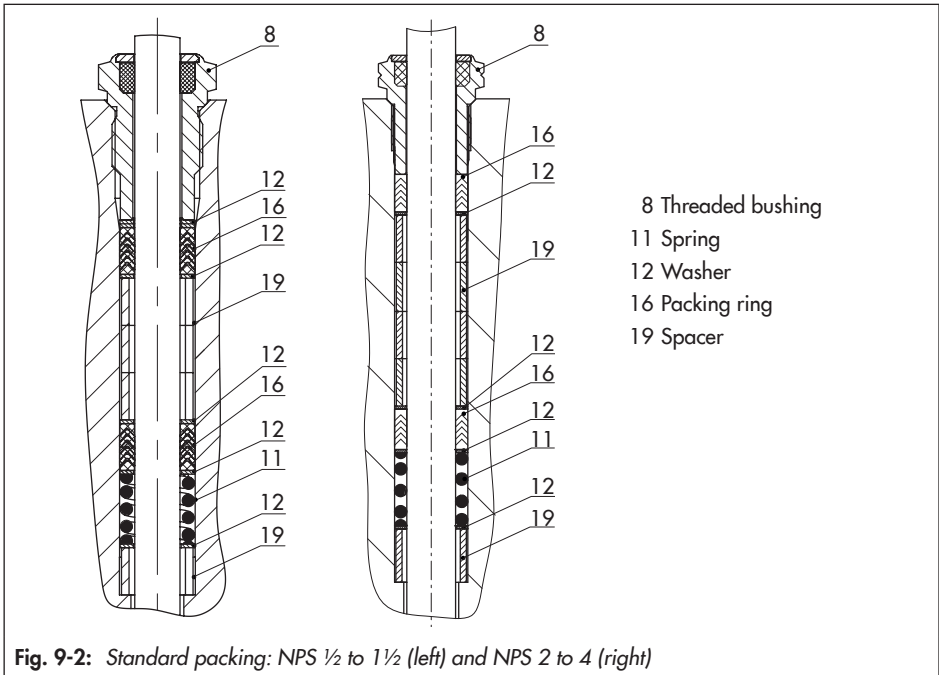

Fig. 9-2: Standard packing: NPS 1/2 to 1 1/2 (left) and NPS 2 to 4 (right)

14. Screw in the threaded bushing (8) and tighten it. Observe tightening torques.
15. Place yoke (3) on the bonnet (2) and fasten using the castellated nut (92).
16. Loosely screw the lock nut (10) and stem connector nut (9) onto the plug stem.

ADSEAL packing

1. Proceed as described in 'Standard packing (PTFE)', steps 1 to 11.
2. Carefully slide the packing parts over the plug stem into the packing chamber using a suitable tool. Observe the proper sequence (see Fig. 9-3).
3. Slide the seals (15.2) over the plug stem.

Insert the wire of the red spacer ring (15.1) into the groove of the retaining ring. Slide the retaining ring over the plug stem.

4. Insert the red spacer ring (15.1) between the threaded bushing (8) and retaining ring. See Fig. 9-3.
5. Proceed as described in 'Standard packing (PTFE)', steps 13 to 16.

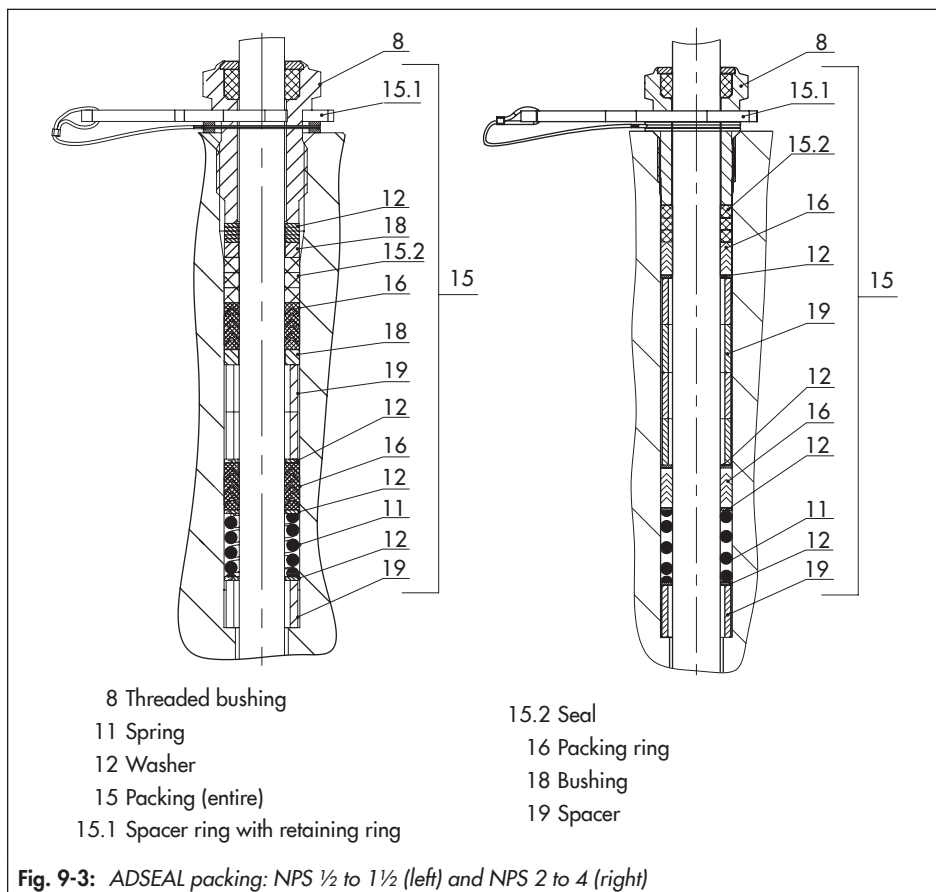

b) Version with insulating section

Standard packing (PTFE)

1. Unscrew the castellated nut (92) and lift the yoke (3) off the insulating section (21).

2. Undo the top body nuts (14) gradually in a crisscross pattern.
3. Lift the insulating section (21) and plug with plug stem (5) off the body (1).
4. Unscrew the stem connector nut (9) and lock nut (10) from the plug stem.
5. Unscrew the threaded bushing (8).

Servicing

6. Pull the plug with plug stem (5) out of the insulating section (21).
7. Pull the entire packing out of the packing chamber using a suitable tool.
8. Renew the damaged parts and carefully clean the packing chamber.
9. Apply a suitable lubricant to all the packing parts and to the plug stem (5).
10. Slide the plug with plug stem (5) into the insulating section (21).
11. Place the insulating section (21) together with the plug stem and plug (5) onto the body.

Version with V-port plug: place the insulating section (21) onto the valve body, making sure that the largest V-shaped part of the V-port plug faces towards the valve outlet.

Version with perforated plug: place the insulating section (21) onto the insulating section, making sure that the hole of the plug that releases the flow first faces toward the valve outlet.

See relevant information under 'Mounting the actuator onto the valve' in the 'Installation' section.

12. Carefully slide the packing parts over the plug stem into the packing chamber using a suitable tool. Observe the proper sequence (see Fig. 9-2).
13. Firmly press the plug (5) into the seat (4). Fasten down the insulating section (21) with the top body nuts (14). Tighten the nuts gradually in a crisscross pattern. Observe tightening torques.
14. Screw in the threaded bushing (8) and tighten it. Observe tightening torques.
15. Place yoke (3) onto the insulating section (21) and fasten using the castellated nut (92).
16. Loosely screw the lock nut (10) and stem connector nut (9) onto the plug stem.

ADSEAL packing

1. Proceed as described in 'Standard packing (PTFE)', steps 1 to 11.
2. Carefully slide the packing parts over the plug stem into the packing chamber using a suitable tool. Observe the proper sequence (see Fig. 9-3).
3. Slide the seals (15.2) over the plug stem.

Legend for Fig. 9-4

1	Body	13	Stud bolt
2	Bonnet	14	Nut
3	Yoke	15	Packing
4	Seat	17	Body gasket
5	Plug (with plug stem)	21	Insulating section
7	Guide bushing	92	Castellated nut
8	Threaded bushing (packing nut)	93	Expansion sleeve (for Class 150 to 2500)
9	Stem connector nut	100	Flange
10	Lock nut		

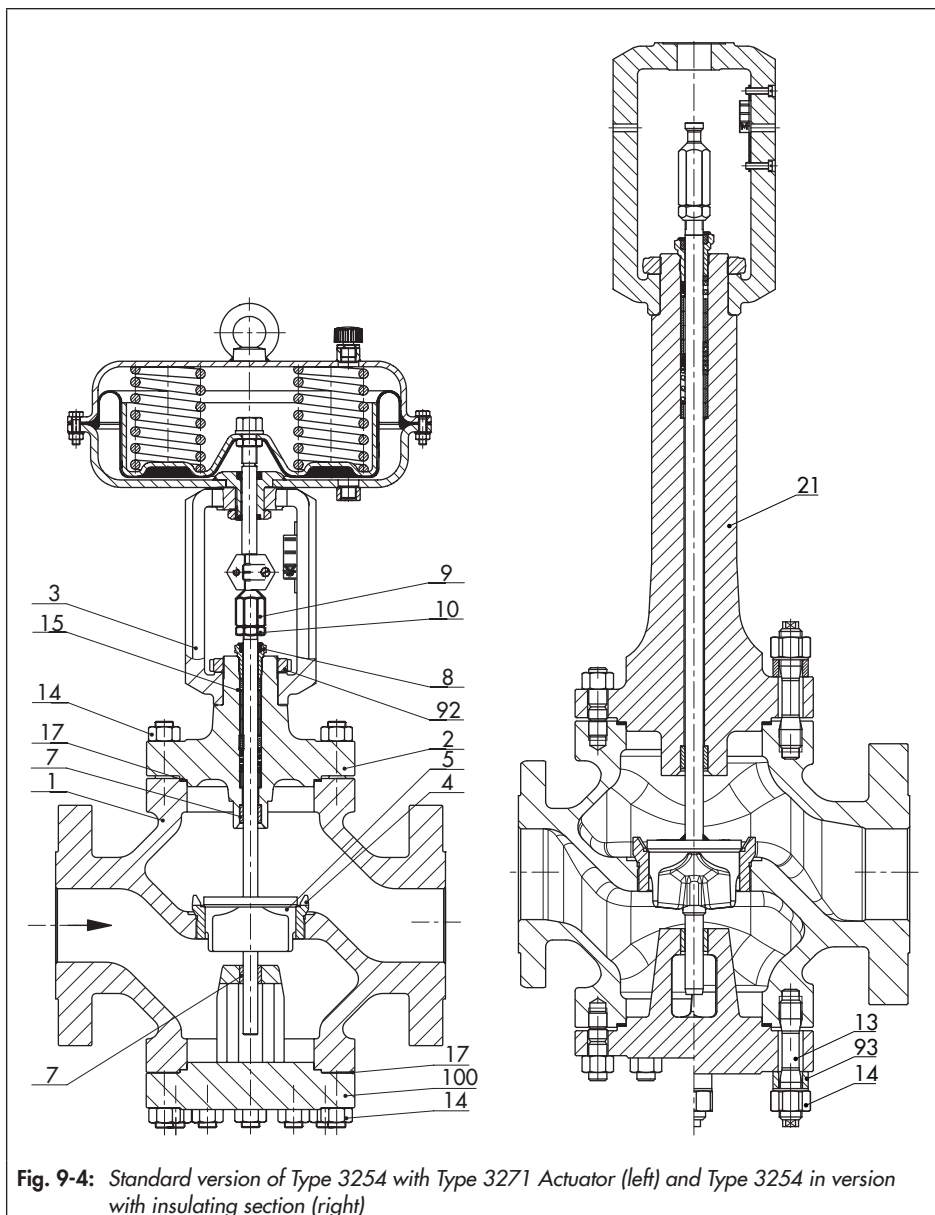

Insert the wire of the red spacer ring (15.1) into the groove of the retaining ring.
Slide the retaining ring over the plug stem.

4. Insert the red spacer ring (15.1) between the threaded bushing (8) and retaining ring. See Fig. 9-3.
5. Proceed as described in 'Standard packing (PTFE)', steps 13 to 16.

9.4.4 Replacing the seat and plug

NOTICE

Risk of control valve damage due to incorrect servicing.

- *Seat and plug can only be replaced when all the following conditions are met:*
- *The valve size is \leq NPS 4.*
 - *The valve does not have a balanced plug.*
 - *The valve does not have a bellows seal.*
 - *The valve does not have a flow divider.*
 - *The valve does not have an AC trim.*
 - *The standard or ADSEAL packing is installed in the valve.*
- *To replace seat and plug in other valve versions, contact our after-sales service.*

NOTICE

Risk of damage to the facing of the seat and plug due to incorrect servicing.

→ *Always replace both the seat and plug.*

Tip

When replacing the seat and plug, we also recommend replacing the packing (see section 9.4.3).

a) Standard version

1. Unscrew the castellated nut (92) and lift the yoke (3) off the bonnet (2).
2. Undo the top body nuts (14) gradually in a crisscross pattern.
3. Lift the bonnet (2) and plug with plug stem (5) off the body (1).
4. Replace the top gasket as described in section 9.4.1.
5. Unscrew the stem connector nut (9) and lock nut (10) from the plug stem.
6. Unscrew the threaded bushing (8).
7. Pull the plug with plug stem (5) out of the bonnet (2).
8. Pull the entire packing out of the packing chamber using a suitable tool.
9. Make sure that the top guide bushing (7) is not damaged. If necessary, replace the guide bushing using a suitable tool.
10. Unscrew the seat (4) using a suitable tool.

11. Apply a suitable lubricant to the thread and the sealing cone of the new seat.
12. Screw in the seat (4). Observe tightening torques.
13. Apply a suitable lubricant to all the packing parts and to the new plug stem (5). We recommend replacing the packing as well. See section 9.4.3.
14. Slide the new plug with plug stem (5) into the bonnet (2).
15. Place the bonnet (2) together with the plug stem and plug (5) onto the body (1).

Version with V-port plug: place the bonnet (2) onto the valve body, making sure that the largest V-shaped part of the V-port plug faces towards the valve outlet.

Version with perforated plug: place the bonnet (2) onto the valve body, making sure that the hole of the plug that releases the flow first faces toward the valve outlet.

See relevant information under 'Mounting the actuator onto the valve' in the 'Installation' section.

16. Carefully slide the packing parts over the plug stem into the packing chamber using a suitable tool. Observe the proper sequence (see Fig. 9-2).
17. Firmly press the plug (5) into the seat (4). Fasten down the bonnet (2) with the top body nuts (14). Tighten the nuts gradually in a crisscross pattern. Observe tightening torques.
18. Screw in the threaded bushing (8) and tighten it. Observe tightening torques.
19. Place yoke (3) on the bonnet (2) and fasten using the castellated nut (92).
20. Loosely screw the lock nut (10) and stem connector nut (9) onto the plug stem.

b) Version with insulating section

1. Unscrew the castellated nut (92) and lift the yoke (3) off the insulating section (21).
2. Undo the top body nuts (14) gradually in a crisscross pattern.
3. Lift the insulating section (21) together with the plug stem and plug (5) off the body (1).
4. Replace the top gasket as described in section 9.4.1.
5. Unscrew the stem connector nut (9) and lock nut (10) from the plug stem (5).
6. Unscrew the threaded bushing (8).
7. Pull the plug with plug stem (5) out of the insulating section (21).
8. Pull the entire packing out of the packing chamber using a suitable tool.
9. Make sure that the top guide bushing (7) is not damaged. If necessary, replace the guide bushing using a suitable tool.
10. Unscrew the seat (4) using a suitable tool.
11. Apply a suitable lubricant to the thread and the sealing cone of the new seat.

Servicing

12. Screw in the seat (4). Observe tightening torques.
13. Apply a suitable lubricant to all the packing parts and to the new plug stem (5). We recommend replacing the packing as well. See section 9.4.3.
14. Slide the new plug with plug stem (5) into the insulating section (21).
15. Place the insulating section (21) together with the plug stem and plug (5) onto the body (1).
Version with V-port plug: place the insulating section (21) onto the valve body, making sure that the largest V-shaped part of the V-port plug faces towards the valve outlet.
Version with perforated plug: place the insulating section (21) onto the insulating section, making sure that the hole of the plug that releases the flow first faces toward the valve outlet.
See relevant information under 'Mounting the actuator onto the valve' in the 'Installation' section.
16. Carefully slide the packing parts over the plug stem extension into the packing chamber using a suitable tool. Observe the proper sequence (see Fig. 9-2).
17. Firmly press the plug (5) into the seat (4). Fasten down the insulating section (21) with the top body nuts (14). Tighten the nuts gradually in a crisscross pattern. Observe tightening torques.
18. Screw in the threaded bushing (8) and tighten it. Observe tightening torques.

19. Place yoke (3) onto the insulating section (21) and fasten using the castellated nut (92).
20. Loosely screw the lock nut (10) and stem connector nut (9) onto the plug stem.

9.5 Ordering spare parts and operating supplies

Contact your nearest SAMSON subsidiary or SAMSON's After-sales Service for information on spare parts, lubricants and tools.

Spare parts

See Annex for details on spare parts.

Lubricant

See document ► AB 0100 for details on suitable lubricants.

Tools

See document ► AB 0100 for details on suitable tools.

10 Decommissioning

The work described in this section is only to be performed by personnel appropriately qualified to carry out such tasks.

⚠ DANGER

Risk of bursting due to incorrect opening of pressurized equipment or components.

Valves and pipelines are pressure equipment that may burst when handled incorrectly.

Flying projectile fragments or the release of process medium under pressure can cause serious injury or even death.

Before working on the control valve:

- Depressurize all plant sections affected and the valve (including the actuator). Release any stored energy.
- Drain the process medium from all the plant sections concerned as well as the valve.

⚠ WARNING

Risk of burn injuries due to hot or cold components and pipeline.

Valve components and the pipeline may become very hot or cold. Risk of burn injuries.

- Allow components and pipelines to cool down or warm up to the ambient temperature.
- Wear protective clothing and safety gloves.

⚠ WARNING

Risk of personal injury due to pressurized components and process medium being discharged.

- Do not loosen the screw of the test connection while the valve is pressurized.

⚠ WARNING

Risk of hearing loss or deafness due to loud noise.

Noise emission (e.g. cavitation or flashing) may occur during operation caused by the process medium and the operating conditions. Additionally, a loud noise may briefly occur through the sudden venting of the pneumatic actuator or pneumatic valve accessories not fitted with noise-reducing fittings. Both can damage hearing.

- Wear hearing protection when working near the valve.

⚠ WARNING

Crush hazard arising from actuator and plug stem moving.

- Do not insert hands or finger into the yoke while the air supply is connected to the actuator.
- Before working on the control valve, disconnect and lock the pneumatic air supply as well as the control signal.
- Do not impede the movement of the actuator and plug stem by inserting objects into the yoke.
- Before unblocking the actuator and plug stem after they have become blocked

Decommissioning

(e.g. due to seizing up after remaining in the same position for a long time), release any stored energy in the actuator (e.g. spring compression). See associated actuator documentation.

WARNING

Risk of personal injury due to exhaust air being vented.

While the valve is operating, air is vented from the actuator, for example, during closed-loop operation or when the valve opens or closes.

→ Wear eye protection when working in close proximity to the control valve.

WARNING

Risk of personal injury due to residual process medium in the valve.

While working on the valve, residual medium can flow out of the valve and, depending on its properties, cause personal injury, e.g. (chemical) burns.

→ Wear protective clothing, safety gloves, respiratory protection and eye protection.

To decommission the control valve for service work or to remove it from the pipeline, proceed as follows:

1. Close the shut-off valves upstream and downstream of the control valve to stop the process medium from flowing through the valve.

2. Completely drain the pipelines and valve.
3. Disconnect and lock the pneumatic air supply to depressurize the actuator.
4. Release any stored energy.
5. If necessary, allow the pipeline and valve components to cool down or warm up to the ambient temperature.

11 Removal

The work described in this section is only to be performed by personnel appropriately qualified to carry out such tasks.

⚠ WARNING

Risk of burn injuries due to hot or cold components and pipeline.

Valve components and the pipeline may become very hot or cold. Risk of burn injuries.

- Allow components and pipelines to cool down or warm up to the ambient temperature.
- Wear protective clothing and safety gloves.

⚠ WARNING

Crush hazard arising from actuator and plug stem moving.

- Do not insert hands or finger into the yoke while the air supply is connected to the actuator.
- Before working on the control valve, disconnect and lock the pneumatic air supply as well as the control signal.
- Do not impede the movement of the actuator and plug stem by inserting objects into the yoke.
- Before unblocking the actuator and plug stem after they have become blocked (e.g. due to seizing up after remaining in the same position for a long time), release any stored energy in the actuator (e.g. spring compression). See associated actuator documentation.

⚠ WARNING

Risk of personal injury due to residual process medium in the valve.

While working on the valve, residual medium can flow out of the valve and, depending on its properties, cause personal injury, e.g. (chemical) burns.

- Wear protective clothing, safety gloves, respiratory protection and eye protection.

⚠ WARNING

Risk of personal injury due to preloaded springs.

Actuators with preloaded springs are under tension. They can be identified by the long bolts protruding from the bottom of the actuator.

- Before starting any work on the actuator, relieve the compression from the preloaded springs.

⚠ WARNING

Risk of personal injury due to incorrect removal of the anti-rotation fixture under tension.

Once the actuator has been mounted on the valve and the assembly is ready for use, the clamps (301) of the anti-rotation fixture on the plug stem are under tension.

- Follow the instructions in this document during mounting or removal.
- Do not loosen the screws (303) of the anti-rotation fixture while the force generated by the supply air and/or the

Removal

actuator springs is transmitted to the actuator stem and the stem (9).

- *First remove the actuator from the valve or ensure it cannot transmit any forces to the actuator stem before removing the anti-rotation fixture on the plug stem.*
-

Before removing the valve, make sure the following conditions are met:

- The control valve is put out of operation (see the 'Decommissioning' section).

11.1 Removing the valve from the pipeline

a) Version with flanges

1. Support the valve to hold it in place when separated from the pipeline (see the 'Shipment and on-site transport' section).
2. Unbolt the flange joint.
3. Remove the valve from the pipeline (see the 'Shipment and on-site transport' section).

b) Version with welding ends

1. Support the valve to hold it in place when separated from the pipeline (see the 'Shipment and on-site transport' section).
2. Cut the pipeline in front of the weld seam.

3. Remove the valve from the pipeline (see the 'Shipment and on-site transport' section).

11.2 Removing the actuator from the valve

See associated actuator documentation.

12 Repairs

If the valve does not function properly according to how it was originally sized or does not function at all, it is defective and must be repaired or exchanged.

! NOTICE

Risk of valve damage due to incorrect service or repair work.

- ➔ Do not perform any repair work on your own.
- ➔ Contact SAMSON's After-sales Service for repair work.

12.1 Returning devices to SAMSON

Defective devices can be returned to SAMSON for repair.

Proceed as follows to return devices:

1. Exceptions apply concerning some special device models ► www.samsongroup.com > Service & Support > After-sales Service.
2. Send an e-mail ► retouren@samsongroup.com to register the return shipment including the following information:
 - Type
 - Article no.
 - Configuration ID
 - Original order

- Completed Declaration on Contamination, which can be downloaded from our website at ► www.samsongroup.com > Service & Support > After-sales Service.

After checking your registration, we will send you a return merchandise authorization (RMA).

3. Attach the RMA (together with the Declaration on Decontamination) to the outside of your shipment so that the documents are clearly visible.
4. Send the shipment to the address given on the RMA.

i Note

Further information on returned devices and how they are handled can be found at ► www.samsongroup.com > Service & Support > After-sales Service.

13 Disposal

- Observe local, national and international refuse regulations.
- Do not dispose of components, lubricants and hazardous substances together with your household waste.

14 Certificates

The declarations of conformity are included on the next pages:

- Declaration of conformity in compliance with Pressure Equipment Directive 2014/68/EU on page 14-2
- Declaration of conformity in compliance with Machinery Directive 2006/42/EC for Types 3254-1 and 3254-7 Control Valves on page 14-3
- Declaration of incorporation in compliance with Machinery Directive 2006/42/EC for the Type 3254 Valve with other actuators other than Types 3271 and 3277 Actuators on page 14-4

The certificates shown were up to date at the time of publishing. The latest certificates can be found on our website:

► www.samsongroup.com > *Products & Applications* > *Product selector* > *Valves* > *3254*

Other optional certificates are available on request.

EU DECLARATION OF CONFORMITY TRANSLATION



Module H / N° CE-0062-PED-H-SAM 001-20-DEU-rev-A

For the following products, SAMSON hereby declares under its sole responsibility:

Devices	Series	Type	Version
Globe valve	240	3241	DIN, body of cast iron from DN 150, body of spheroidal-graphite iron, from DN 100, fluids G2, L1, L2 ¹⁾ DIN/ANSI, body of steel, etc., all fluids
Three-way valve	240	3244	DIN, body of cast iron from DN 150, body of spheroidal-graphite iron, from DN 100, fluids G2, L1, L2 ¹⁾ DIN/ANSI, body of steel, etc., all fluids
Cryogenic valve	240	3248	DIN/ANSI, all fluids
Globe valve	250	3251	DIN/ANSI, all fluids
Globe valve	250	3251-E	DIN/ANSI, all fluids
Three-way valve	250	3253	DIN/ANSI, body of steel, etc., all fluids
Globe valve	250	3254	DIN/ANSI, all fluids
Angle valve	250	3256	DIN/ANSI, all fluids
Split-body valve	250	3258	DIN, all fluids
Angle valve (IG standards)	250	3259	DIN, all fluids
Steam-converting valve	280	3281	DIN/ANSI, all fluids
		3284	DIN/ANSI, all fluids
		3286	DIN/ANSI, all fluids
		3288	DIN, all fluids
Globe valve	V2001	3321	DIN, body of steel, etc., all fluids ANSI, all fluids
		3323	DIN, body of steel, etc., all fluids ANSI, all fluids
Angle seat valve	---	3353	DIN, body of steel, etc., all fluids
Silencer	3381	3381-1	DIN/ANSI, single attenuation plate with welding ends, all fluids
		3381-3	DIN/ANSI, all fluids
		3381-4	DIN/ANSI, single attenuation plate multi-stage with welding ends, all fluids
		3241	ANSI, body of cast iron, Class 125, from NPS 5, fluids G2, L1, L2 ¹⁾
Globe valve	240	3241	ANSI, body of cast iron, Class 125, from NPS 5, fluids G2, L1, L2 ¹⁾
Cryogenic valve	240	3246	DIN/ANSI, all fluids
Three-way valve	250	3253	DIN, body of cast iron from DN200 PN16, fluids G2, L1, L2 ¹⁾
Globe valve	290	3291	ANSI, all fluids
Angle valve	290	3296	ANSI, all fluids
Globe valve	590	3591	ANSI, all fluids
Angle valve	590	3596	ANSI, all fluids
Cryogenic valve	590	3598	ANSI, NPS 3 to NPS 8, Class 900, all fluids
Control valve	---	3595	ANSI, all fluids

¹⁾ Gases according to Article 4(1)(c.i), second indent
Liquids according to Article 4(1)(c.ii)

that the products mentioned above comply with the requirements of the following standards:

Directive of the European Parliament and of the Council on the harmonization of the laws of the Member States relating to the making available on the market of pressure equipment	2014/68/EU	of 15 May 2014
Applied conformity assessment procedure for fluids according to Article 4(1)	Module H	by Bureau Veritas 0062

The manufacturer's quality management system is monitored by the following notified body:
Bureau Veritas Services SAS, 8 Cours du Triangle, 92800 PUTEAUX - LA DEFENSE
Technical standards applied: DIN EN12516-2, DIN EN12516-3, ASME B16.34

Manufacturer: SAMSON AG, Weismuellerstrasse 3, 60314 Frankfurt am Main, Germany
Frankfurt am Main, 7 April 2021



Dr. Andreas Wild
Chief Executive Officer (CEO)



Dr. Thomas Steckmeiter
Chief Technology Officer (CTO)

Revision 08

EU DECLARATION OF CONFORMITY TRANSLATION



Declaration of Conformity of Final Machinery

in accordance with Annex II, section 1.A. of the Directive 2006/42/EC

For the following products:

Types 3254-1/7 Pneumatic Control Valves consisting of the Type 3254 Valve and Type 3271/Type 3277 Pneumatic Actuator

We hereby declare that the machinery mentioned above complies with all applicable requirements stipulated in Machinery Directive 2006/42/EC.

For product descriptions of the valve and actuator, refer to:

- Type 3254 Valve (DIN): Mounting and Operating Instructions EB 8060
- Type 3254 Valve (ANSI): Mounting and Operating Instructions EB 8061
- Types 3271 and 3277 Actuators: Mounting and Operating Instructions EB 8310-X

Valve accessories (e.g. positioners, limit switches, solenoid valves, lock-up valves, supply pressure regulators, volume boosters and quick exhaust valves) are classified as machinery components in this declaration of conformity and do not fall within the scope of the Machinery Directive as specified in § 35 and § 46 of the Guide to Application of the Machinery Directive 2006/42/EC issued by the European Commission. In the SAMSON Manual H 02 titled "Appropriate Machinery Components for SAMSON Pneumatic Control Valves with a Declaration of Conformity of Final Machinery", SAMSON defines the specifications and properties of appropriate machinery components that can be mounted onto the above specified final machinery.

Referenced technical standards and/or specifications:

- VCI, VDMA, VGB: "Leitfaden Maschinenrichtlinie (2006/42/EG) – Bedeutung für Armaturen, Mai 2018" [German only]
- VCI, VDMA, VGB: "Zusatzdokument zum „Leitfaden Maschinenrichtlinie (2006/42/EG) – Bedeutung für Armaturen vom Mai 2018" [German only], based on DIN EN ISO 12100:2011-03

Comment:

Information on residual risks of the machinery can be found in the mounting and operating instructions of the valve and actuator as well as in the referenced documents listed in the mounting and operating instructions.

Persons authorized to compile the technical file:

SAMSON AG, Weismüllerstraße 3, 60314 Frankfurt am Main, Germany
Frankfurt am Main, 27 November 2020

Peter Arzbach
Director
Product Management

Peter Scheermesser
Director
Product Life Cycle Management and ETO
Development for Valves and Actuators

Revision no. 00

DECLARATION OF INCORPORATION TRANSLATION



Declaration of Incorporation in Compliance with Machinery Directive 2006/42/EC

For the following products:

Type 3254 Pneumatic Control Valve

We certify that the Type 3254 Pneumatic Control Valves are partly completed machinery as defined in the Machinery Directive 2006/42/EC and that the safety requirements stipulated in Annex I, 1.1.2, 1.1.3, 1.1.5, 1.3.2, 1.3.4 and 1.3.7 are observed. The relevant technical documentation described in Annex VII, part B has been compiled.

Products we supply must not be put into service until the final machinery into which it is to be incorporated has been declared in conformity with the provisions of the Machinery Directive 2006/42/EC.

Operators are obliged to install the products observing the accepted industry codes and practices (good engineering practice) as well as the mounting and operating instructions. Operators must take appropriate precautions to prevent hazards that could be caused by the process medium and operating pressure in the valve as well as by the signal pressure and moving parts.

The permissible limits of application and mounting instructions for the products are specified in the associated data sheets as well as the mounting and operating instructions; the documents are available in electronic form on the Internet at www.samsongroup.com.

For product descriptions of the valve, refer to:

- Type 3254 Valve (DIN): Mounting and Operating Instructions EB 8060
- Type 3254 Valve (ANSI): Mounting and Operating Instructions EB 8061

Referenced technical standards and/or specifications:

- VCI, VDMA, VGB: Leitfaden Maschinenrichtlinie (2006/42/EG) – Bedeutung für Armaturen, May 2018 [German only]
- VCI, VDMA, VGB: Zusatzdokument zum „Leitfaden Maschinenrichtlinie (2006/42/EG) – Bedeutung für Armaturen“ vom Mai 2018 [German only], based on DIN EN ISO 12100:2011-03

Comments:

- See mounting and operating instructions for residual hazards.
- Also observe the referenced documents listed in the mounting and operating instructions.

Persons authorized to compile the technical file:

SAMSON AG, Weismüllerstraße 3, 60314 Frankfurt am Main, Germany
Frankfurt am Main, 27 November 2020



Peter Arzbach
Director
Product Management



Peter Scheermesser
Director
Product Life Cycle Management and ETO
Development for Valves and Actuators

Revision no. 00

15 Annex

15.1 Tightening torques, lubricants and tools

- ▶ AB 0100 for tools, tightening torques and lubricants

15.2 Spare parts

- | | |
|---|---|
| 1 Body | 46 Gasket ¹⁾ |
| 2 Bonnet | 47 Support ¹⁾ |
| 3 Yoke | 48 Hex screw ¹⁾ |
| 4 Seat | 49 Hex screw ¹⁾ |
| 5 Plug | 50 Lock ¹⁾ |
| 7 Guide bushing | 51 Guide ¹⁾ (several guides only for version with graphite seal) |
| 8 Threaded bushing (packing nut) | 52 Ring ¹⁾ (only for version with graphite seal) |
| 9 Stem connector nut | 53 Snap ring ¹⁾ |
| 10 Lock nut | 61 Flow divider ST 2 ²⁾ |
| 11 Spring | 62 Flow divider ST 1 or ST 3 ²⁾ |
| 12 Washer | 63 Ring ²⁾ |
| 13 Stud bolt | 64 Gasket ²⁾ |
| 14 Body nut | 65 Gasket ²⁾ |
| 15 Packing | 80 Nameplate |
| 16 V-ring packing | 81 Grooved pin |
| 17 Body gasket | 82 Screw |
| 19 Bushing | 83 Hanger |
| 21 Insulating section | 84 Travel indicator scale |
| 22 Bellows seal | 85 Screw |
| 24 Guide bushing | 91 Protective caps |
| 26 Label (bellows seal or insulating section) | 92 Castellated nut |
| 27 Flange | 93 Expansion sleeve |
| 28 Clamping ring | 94 Expansion sleeve ³⁾ |
| 29 Plug for version with bellows seal | 100 Flange |
| 31 Washer | 101 Bellows bonnet |
| 29 Plug for version with bellows seal | 102/103 Screw with snap ring ¹⁾ (only for version with bellows seal) |
| 32 Screw | |
| 33 Nut | |
| 34 Bolt | |
| 37 Plug stem with metal bellows | |
| 39 Gasket | |
| 42 Screw plug with seal | |
| 44 Ring/ring nut ¹⁾ | |
| 45 Packing ring ¹⁾ | |

¹⁾ Version with balanced valve plug

²⁾ Version with flow divider

³⁾ With NPS 3 to 6 only

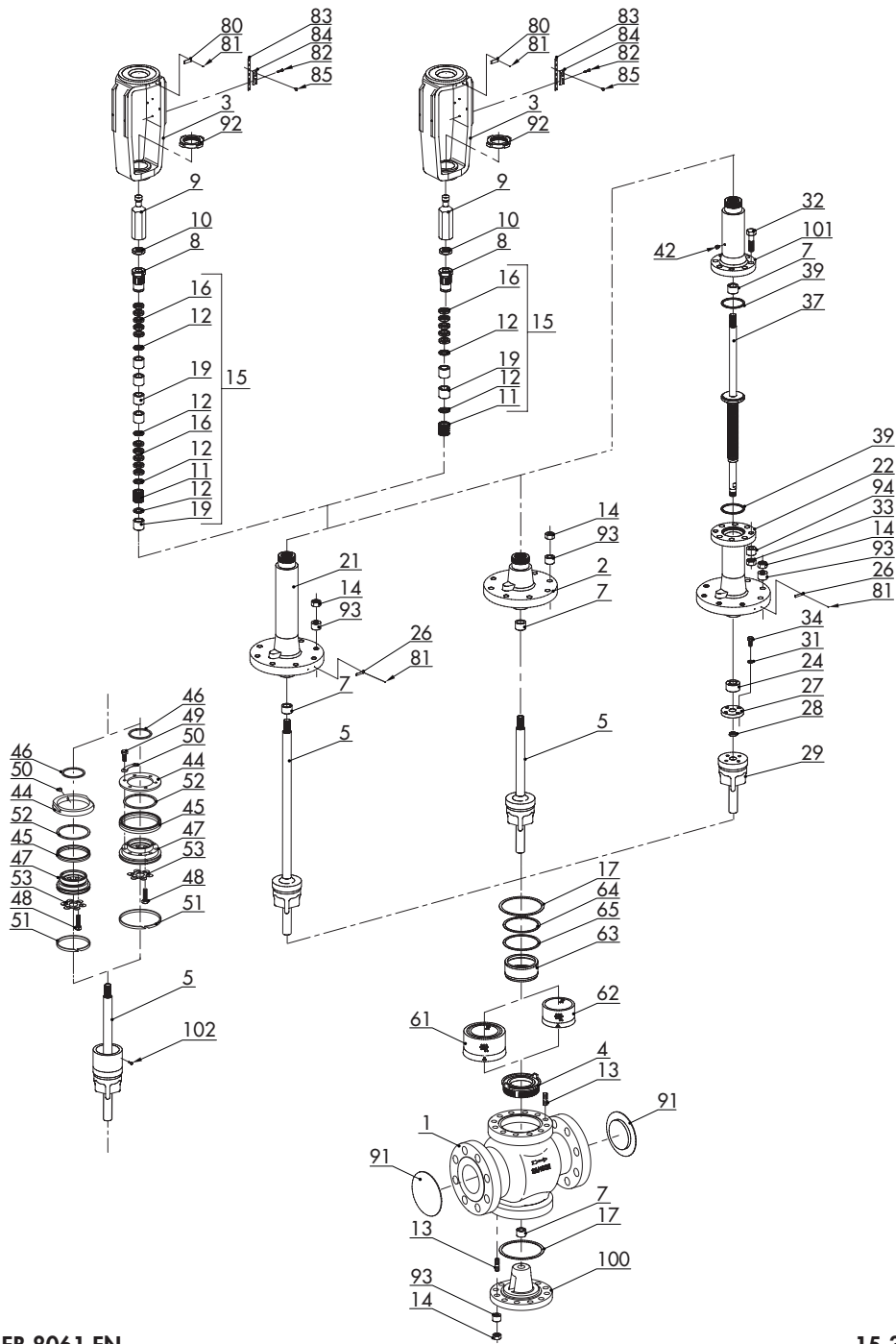

15.3 After-sales service

Contact our after-sales service for support concerning service or repair work or when malfunctions or defects arise.

E-mail address

You can reach our after-sales service at aftersalesservice@samsongroup.com.

Addresses of SAMSON AG and its subsidiaries

The addresses of SAMSON AG, its subsidiaries, representatives and service facilities worldwide can be found on our website (www.samsongroup.com) or in all SAMSON product catalogs.

Required specifications

Please submit the following details:

- Order number and position number in the order
- Type, model number, valve size and valve version
- Pressure and temperature of the process medium
- Flow rate in cu.ft./min or m³/h
- Bench range of the actuator (e.g. 0.2 to 1 bar)
- Is a strainer installed?
- Installation drawing

EB 8061 EN



SAMSON AKTIENGESELLSCHAFT
Weismüllerstraße 3 · 60314 Frankfurt am Main, Germany
Phone: +49 69 4009-0 · Fax: +49 69 4009-1507
samson@samsongroup.com · www.samsongroup.com