

MOUNTING AND OPERATING INSTRUCTIONS

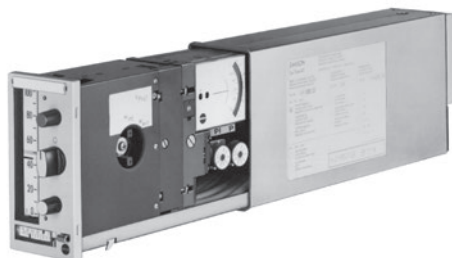

EB 7500 EN

Translation of original instructions



Type 3421 Compact Controller with Type 3422 Controller Station and Type 3423 Controller Module



Type 3417 Pneumatic Control Unit



Type 3416 Indicator Control Unit



Type 3427 Manual Control Station



Type 3425 Pneumatic Controller (control room installation)



Type 3425 Pneumatic Controller (field unit)

Series 420 Pneumatic Control System

Edition July 2017



Note on these mounting and operating instructions

These mounting and operating instructions assist you in mounting and operating the device safely. The instructions are binding for handling SAMSON devices.

- For the safe and proper use of these instructions, read them carefully and keep them for later reference.
- If you have any questions about these instructions, contact SAMSON's After-sales Service Department (aftersaleservice@samson.de).



The mounting and operating instructions for the devices are included in the scope of delivery. The latest documentation is available on our website at www.samson.de > **Service & Support** > **Downloads** > **Documentation**.

⚠ WARNING

Damage to health relating to the REACH regulation.

If a SAMSON device contains a substance which is listed as being a substance of very high concern on the candidate list of the REACH regulation, this circumstance is indicated on the SAMSON delivery note. Information on safe use of the part affected, see ► <http://www.samson.de/reach-en.html>.

Definition of signal words

⚠ DANGER

Hazardous situations which, if not avoided, will result in death or serious injury

⚠ WARNING

Hazardous situations which, if not avoided, could result in death or serious injury

ⓘ NOTICE

Property damage message or malfunction

ℹ Note

Additional information

💡 Tip

Recommended action

1	General safety instructions	5
2	Application	6
3	Operation	6
3.1	Settings at the controller modules	6
3.1.1	Direction of action.....	6
3.1.2	Air delivery	7
3.1.3	Proportional-action coefficient KP	8
3.1.4	Reset time T_n	8
3.1.5	Derivative-action time T_v	8
3.1.6	Operating point.....	8
3.2	Adjusting the limit contacts	9
4	Start-up and settings	10
4.1	Tuning the controller	10
4.2	Bumpless automatic/manual mode changeover.....	12
4.3	Readjusting the controller zero point.....	12
4.4	Additional modules.....	12
4.4.1	Type 3424-4 Manual/automatic Transfer.....	12
4.4.2	Type 3424-5 Control Mode Changeover.....	12
4.4.3	Type 3424-6 Signal Limiter.....	13
5	Design and principle of operation	14
5.1	Type 3421 Compact Controller	14
5.2	Type 3427 Manual Control Station.....	16
5.3	Type 3425 Pneumatic Controller (wall-mounted and field controller).....	16
5.4	Type 3416 Indicator.....	17
5.5	Type 3417 Pneumatic Control Unit	17
5.6	Type 3423 Controller Modules.....	18
5.7	Additional modules.....	21
5.7.1	Type 3424-2x for i/p conversion.....	21
5.7.2	Type 3424-4 for bumpless manual/automatic switchover.....	22
5.7.3	Type 3424-5 for control mode changeover.....	22
5.7.4	Type 3424-6 for signal limitation	22
5.8	Optional electrical limit contacts.....	23

Contents

6	Installation	24
6.1	Changing scales	25
7	Connections	26
7.1	Pneumatic connections.....	26
7.2	Electrical connections	28
8	Maintenance	30
8.1	Checking the air supply	30
9	Conversion.....	30
9.1	Changing the controller function.....	30
9.2	Operating mode changeover in Type 3424-2 i/p Converter.....	33
9.3	Checking the controller function	34
10	Technical data	35



1 General safety instructions

- The device must be mounted, started up, or serviced by fully trained and qualified personnel only; the accepted industry codes and practices are to be observed. Make sure employees or third persons are not exposed to any danger.
- All safety instructions and warnings given in these mounting and operating instructions, particularly those concerning installation, start-up, and maintenance, must be strictly observed.
- Devices with a CE marking have an EC declaration of conformity, which includes information about the applied conformity assessment procedure. The EC Declaration of Conformity is available on request.
- According to these mounting and operating instructions, trained personnel refers to individuals who are able to judge the work they are assigned to and recognize possible dangers due to their specialized training, their knowledge and experience as well as their knowledge of the applicable standards.
- To ensure appropriate use, only use the device in applications where the operating pressure and temperatures do not exceed the specifications used for sizing the device at the ordering stage.
- The manufacturer does not assume any responsibility for damage caused by external forces or any other external factors.
- Proper transport, storage, installation, operation, and maintenance are assumed.

2 Application

The Series 420 Control System is used in automation applications in process engineering and industrial plants. It can be used for applications with P, PI, PID, and PD controls, for control loops with control mode changeover or signal limitation, for fixed set point, ratio, cascade, or slave control.

The output signals of a connected transmitter or master controller are measured as pneumatic standardized signals between 0.2 and 1 bar or, in case of i/p additional modules, 0/4 to 20 mA signals.

The integrated controller modules compare the measured variable with the set point and issue a corresponding pneumatic control signal of 0.2 to 1 bar (2 to 15 psi).

The controller requires a supply pressure of 1.4 bar (20 psi).

3 Operation

3.1 Settings at the controller modules

NOTICE

The settings for direction of action and air delivery must be performed prior to start-up. Release the lock (4 in Fig. 1) on the front panel of the compact controller and pull the manual control station completely out of the housing to access the controller module.

3.1.1 Direction of action

The direction of action for the control loop is set at the turnboard **A**. The position of its arrow symbol according to the arrow symbol on the controller module determines the direction of action of the controller (Fig. 1).

- < > Arrow tips facing opposite directions:
Direction of action increasing/decreasing
As the controlled variable x increases, the output pressure y falls.
- >> Arrow tips facing the same direction:
Direction of action increasing/increasing
As the controlled variable x increases, the output pressure y increases.

Setting or changing the direction of action:

Unscrew the screw in turnboard **A** and lift it off together with the turnboard. If necessary, lever the board at the side. Do not lose the rubber seal.

- Turn the board by 90° so that the required arrow is aligned with the arrow on the base plate.
- Insert board and tighten the screw.

- >yA Normal air delivery, approx. 1 m_n³/h per % of the system deviation (default setting)
- >R High air delivery, approx. 3 m_n³/h per % of the system deviation (not with P or PD controller modules)

3.1.2 Air delivery

(only with Type 3423 Controller Module)

The position of turnboard **B** with its arrow symbol determines the air delivery to the feedback bellows.

Setting or changing the air delivery

If the control valve that is to be controlled is more than 15 meters away, increase the air delivery by turning the position of turnboard **B** from yA (standard) to R.

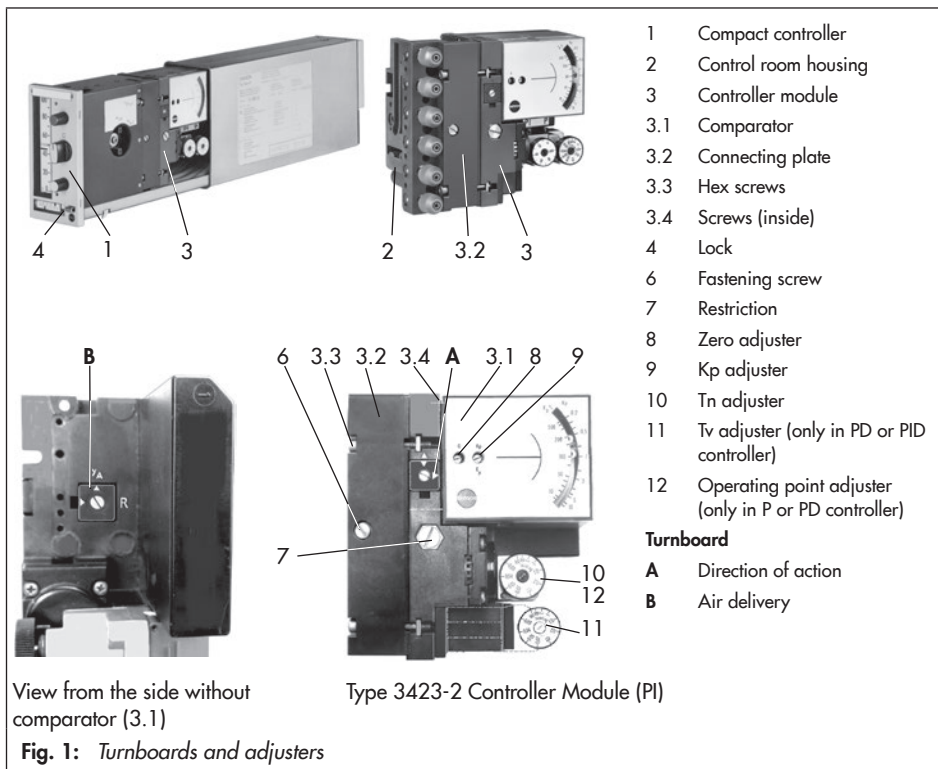

Operation

1. Unscrew the fastening screw (6) at the controller module and pull the module off its self-seal push-on fittings.
2. Unscrew screws (3.3) and pull off the connecting plate (3.2) together with square nuts and bolts from the controller module.
3. Unscrew the hexagonal socket head screws (3.4) at the side and lift the comparator (3.1) off the controller module.
4. Unscrew the screw in turnboard **B** and lift it off together with the turnboard. If necessary, lever the board at the side. Do not lose the rubber seal.
5. Turn the board so that the arrow is aligned with **yA** or **R** on the controller module. Insert board and tighten the screw.
6. Remount the controller module and fasten it in the controller station.

3.1.3 Proportional-action coefficient K_p

The setting of the K_p (adjuster 9) determines the controller gain and depends on the controlled system that is to be tuned (see section 4.1).

3.1.4 Reset time T_n

Controller versions with integral-action component require the reset time to be set at the adjuster (10). The setting depends on the controlled system that is to be tuned (see section 4.1).

3.1.5 Derivative-action time T_v

Controller versions with derivative-action component require the derivative-action time T_v to be set at the adjuster (11). The setting depends on the controlled system that is to be tuned (see section 4.1).

3.1.6 Operating point

Controller modules without integral-action component (e.g. P or PD, controllers) have an operating point.

This can be adjusted at the operating point adjuster (12) between 0 and 100 %, which corresponds to 0.2 to 1 bar.

The setting depends on the output pressure y that is to be tuned (see section 4.1).

The Type 3423-9 Controller Module does not have an operating point adjuster. The operating point is dependent on the set point.

3.2 Adjusting the limit contacts

i Note

The listed limit contacts are no longer available.

Inductive contacts in Type 3422 Manual Control Station and Type 3427 Manual Control Unit

- Release lock on the front panel and pull out the indicating unit.

The proximity switches with min. and max. contacts can be accessed through the opening on the left-hand side.
- Use a 2.5 mm hex screwdriver to slightly loosen the two fastening screws.
- Move the corresponding proximity switch until the indicator points to the required value on the reference scale and a contact is made over the connected switching amplifier or the LED on the front lights up when contact is made.
- Retighten screws and place the marker on the main scale at the corresponding place.

Inductive and pneumatic contacts in Type 3416 Pneumatic Indicator

- Release lock on the front panel and pull out the indicating unit.
- Move adjuster at the side until contact is made.

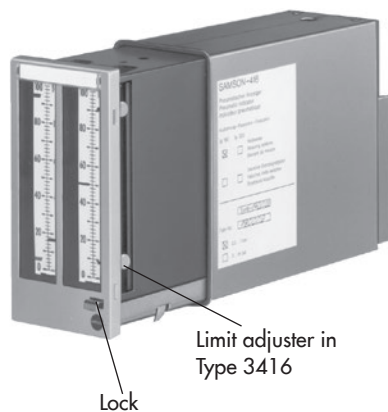
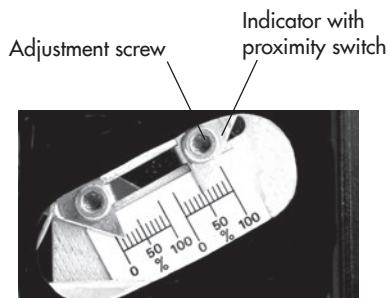

Fig. 2: Indicator with limit contacts

4 Start-up and settings

Before start-up of the control loop, check all devices to make sure that they are connected correctly, do not leak, and function properly.

Release lock (7) and pull out the plug-in unit of the compact controller station for easier access to the operating controls at the controller.

Check the turnboard to make sure the correct direction of action is set at the controller (see section 3.1.1). Set arrow symbol (6) for valve position at 100 % signal pressure accordingly:

Arrow symbol facing:



Upward: valve OPEN

Downward: valve CLOSED

4.1 Tuning the controller

The controller needs to be tuned to the characteristics of the controlled system using the K_p and T_n and/or T_v adjusters at the controller module (Fig. 1) to ensure that the controller can keep any system deviations for all set points caused by the disturbance variables to zero or at least minimize them.

The tuning test following the Ziegler and Nichols method is a simple way to tune the controller. In this method, the controller runs in closed-loop operation with P action to the point where it is still stable. It can only be applied to controlled systems in which the controlled variable can be made to hunt.

1. Set manual/automatic switch (10) to **manual**. Apply supply pressure (1.4 ± 0.1 bar) to Z.

2. Set the proportional-action coefficient K_p to a low value (0.2) at the comparator.
PI and PID controllers only: set T_n restrictor to its maximum value (50 min) and T_v to its lowest value (0.01 min).
3. Adjust the set point at the top rotary knob (11) until the green pointer (2) points to the required value on the scale.

PI and PID controllers:

4. Adjust the manual output y_H at the bottom rotary knob (9) to start up the control loop until the controlled variable indicated by the red pointer (3) slowly approaches the adjusted set point (green pointer).

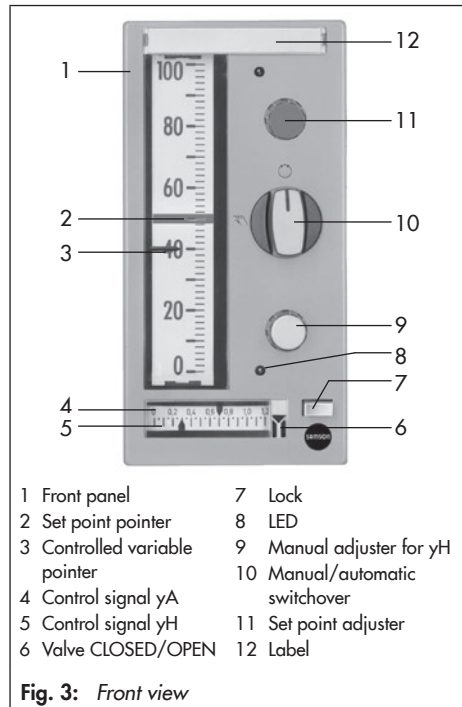

When the pointers meet, wait until also the automatic output (4) on the bottom scale reaches the manual output (5).

If necessary, slightly adjust the set point to allow the automatic output to match the manual output more quickly. After they match, set the set point back to the controlled variable. Continue as described in 5.

P and PD controllers with operating point adjuster:

- Set the manual/automatic switch to automatic.
- Adjust the operating point at the operating point adjuster in the range between 0 and 100 % until the controlled variable (red pointer) is identical with the adjusted set point (green pointer). Continue as described in 6.

5. Change the manual/automatic switch to **automatic**.
6. Starting from a low value, increase the proportional-action coefficient K_p until the red controlled variable pointer shows an harmonic oscillation pattern of the controlled variable (uniform oscillation amplitudes as shown in Fig. 4).

If oscillations do not arise with a large K_p setting, turn the rotary knob to slightly change the set point and then return it to its former setting. It may be necessary to increase the gain (K_p) slightly until an harmonic oscillation pattern arises.

7. Write down the adjusted value on the K_p scale you have just adjusted as the critical proportional-action coefficient $K_{p, crit}$.

PI and PID controllers:

Use a stopwatch to time the oscillation time for one entire oscillation to find T_{crit} .

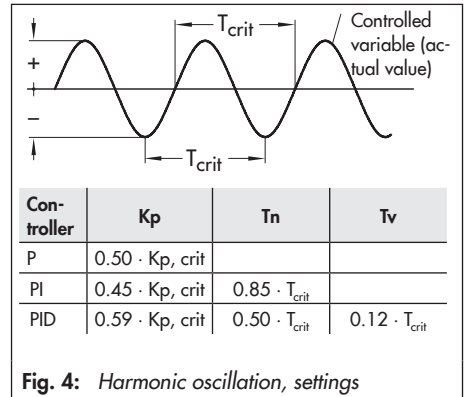

Fig. 4: Harmonic oscillation, settings

8. Multiply value for $K_{p, crit}$ and value for T_{crit} (with PI/PID controller) with the values in the table (Fig. 4) and set them as the favorable settings for K_p , T_n , and T_v at the controller.

Should oscillations still occur despite these settings, slightly reduce K_p and increase T_n . Repeat these steps, if necessary, until the control loop shows a satisfactory performance.

Leave enough time in between settings to allow the controller to stabilize.

Note

If the set point (reference variable) of the P or PD controller is changed, readjust the operating point. When the reference variable is often changed, adjust the operating point to an average value (e.g. 50 %).

i Note

If a P/PI controller is switched to P action, completely open the Tn restrictor to ensure the operating point adjuster can take effect without delay.

Version with set-point-dependent operating point

This version does not need to be adjusted since the operating point automatically follows the set point w.

4.2 Bumpless automatic/manual mode changeover

The bumpless switchover ensures that no pressure surges can reach the valve when the manual/automatic switch (10) is activated as follows:

Changeover from automatic to manual

Use the adjuster (9) to adjust the manual output yH until the pointers (4 and 5) in the bottom display meet. Change the switch over to manual.

Changeover from manual to automatic

If the system is to be controlled manually to the required value, the automatic output yA must be adjusted at the set point adjuster (11) to match the manual output yH.

The switch (10) can only be set to automatic after the pointers (4 and 5) in the bottom display meet.

4.3 Readjusting the controller zero point

If deviations arise between the controlled variable and set point during operation, the zero point can be readjusted by turning the zero adjuster (8 in Fig. 1) until the controlled variable and set point on the front display are the same again.

4.4 Additional modules

i Note

The Type 3424 Additional Module is no longer available.

4.4.1 Type 3424-4 Manual/automatic Transfer



Switchover is performed automatically by activation of the manual/automatic switch (10, Fig. 3). See ► T 7523.

4.4.2 Type 3424-5 Control Mode Changeover

► T 7523

Adjusting the direction of action

Set the direction of action at the turnboard of the control mode changeover device to match the direction of action of turnboard A of the controller module. To proceed, unfasten the screw on the turnboard and turn the board as follows:

- < > **Increasing/decreasing:**
- Position  $(x-w) \leq 0$
- > > **Increasing/increasing:**
- Position  $(x-w) \geq 0$

Setting the control error

The setting depends on the system and must be determined by experimenting.

Starting with a high value, perform the setting in steps with an increasingly smaller control error.

To ensure that the switchover point for P and PI or PD and PID control mode is not continuously exceeded, set the control error $(x-w)$, keeping the error deviations that occur in the system due to constant disturbances within the adjusted $(x-w)$ range.

It is often recommendable to set the control error $(x-w)$ to be double the K_p value set at the controller module.

Setting the operating point

When the system is in a steady-state condition, move the operating point adjuster to the value of the manual output y_A (reading at the manual control station) (0 to 100 % correspond to an output of 0.2 to 1 bar).

In case of large and frequently changing reference variables, we recommend setting it to 50 %.

Set-point-dependent operating point

In this version, the operating point is automatically tracked, meaning that the system deviation remains at zero. The set point adjuster allows, however, a proportional shift of ± 20 %.

Feedback limitation

The additional feedback limitation allows the output pressure y_A to be limited. In this case, the 0 to 100 % scale of the adjuster corresponds to a limitation signal of 0.2 to 1 bar.

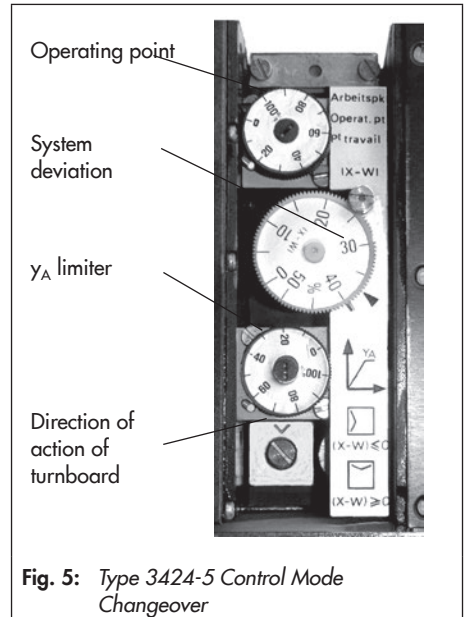

Fig. 5: Type 3424-5 Control Mode Changeover

4.4.3 Type 3424-6 Signal Limiter

Use the corresponding adjusters to perform the minimum or maximum signal limitation (Fig. 13). In this case, the 0 to 100 % scale of the adjuster corresponds to a limitation signal of 0.2 to 1 bar. See ► T 7523.

5 Design and principle of operation

The pneumatic control system has a modular design. As a result, the compact control equipment can be combined with various controller modules and additional modules and adapted to a wide range of applications.

5.1 Type 3421 Compact Controller

The Type 3421 Pneumatic Compact Controller consists of the Type 3422 Manual Control Station and the Type 3423 Controller Module.

The manual control station consists mainly of the housing (1.1) with connecting plate (1.4) and the plug-in unit (1.2) to hold the controller module (1.3). The plug-in unit has self-seal push-on fittings, allowing the device to

also function as a control station when no other components are used.

The controlled variable and set point pointers have metal bellows measuring elements. The controlled variable measuring element can optionally be equipped with adjustable inductive limit contacts or LEDs.

Three versions of the Type 3422 Manual Control Station are available, which are adapted to the control task. Depending on the circuit version 1, 2 or 9, the device does not have the set point adjuster (11), set point pointer (2), or selector switch (14) for internal (w_{int}) or external (w_{ext}) reference variable.

All circuit versions have the ports **R** (feedback) and **y** (output pressure) connected internally to the connecting plate of the compact controller.

In case **y** and **R** are to be routed separately out of the device, proceed as described in section 7.1 by relocating the O-rings on the connecting plate.

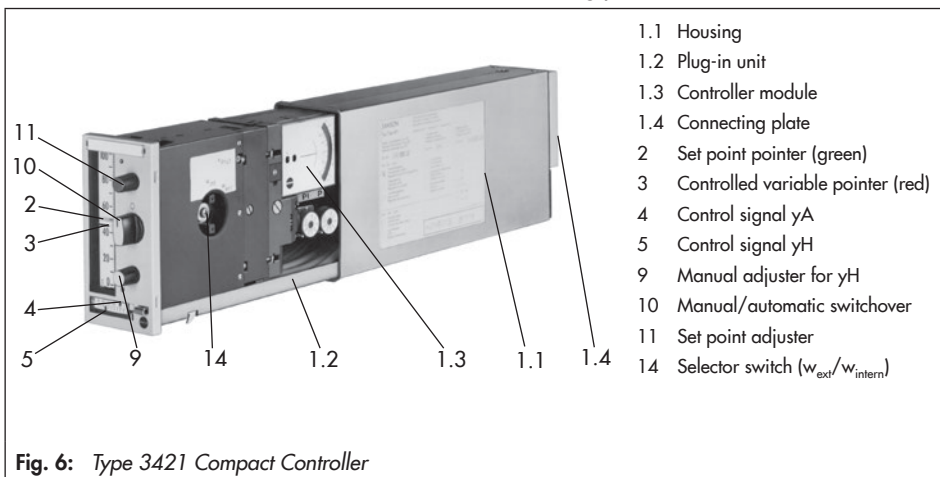
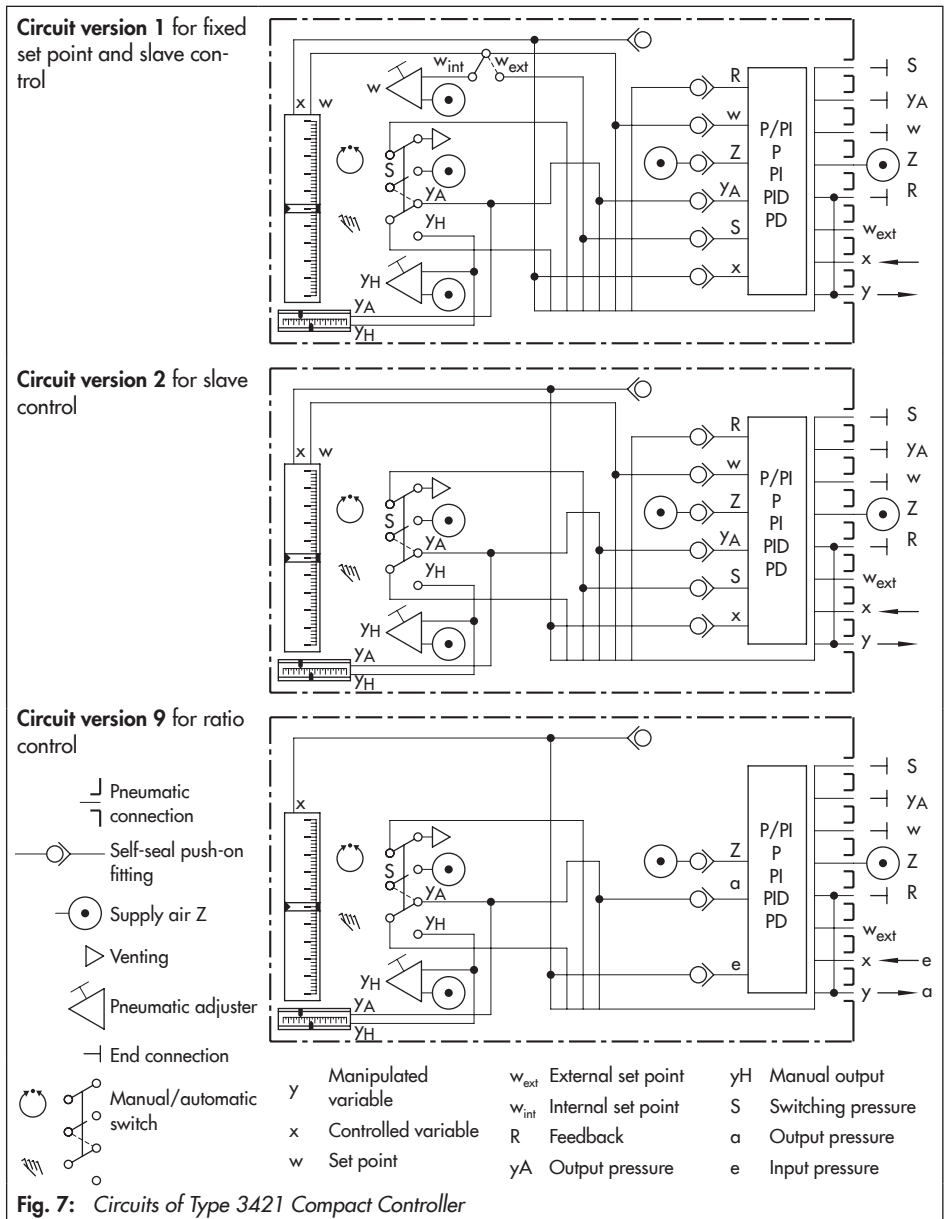

Fig. 6: Type 3421 Compact Controller



5.2 Type 3427 Manual Control Station

The Type 3427 Manual Control Station is used in combination with the Type 3425 Pneumatic Controller (in a Type 3426 Control Room or Field Housing).

The three different versions (Type 3427-1, Type 3427-2, and Type 3427-9) are adapted to control tasks and corresponds to the circuits of Type 3422 Manual Control Station. See ▶ T 7511.

5.3 Type 3425 Pneumatic Controller (wall-mounted and field controller)

The pneumatic controllers for control room or field installation consist of the Type 3426 Control Room or Field Housing and a Type 3423 Controller Module.

The controller module is connected over self-seal push-on fittings to the housing and fastened with a screw (6). See ▶ T 7512.

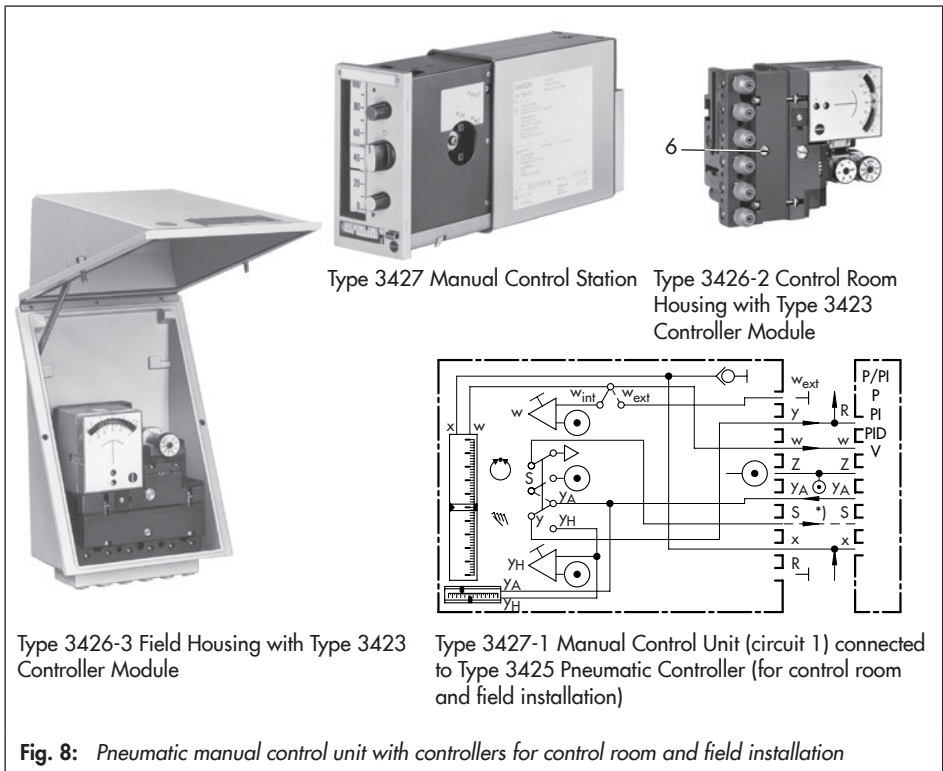

Fig. 8: Pneumatic manual control unit with controllers for control room and field installation

5.4 Type 3416 Indicator

The pneumatic indicators are used when connected to control equipment to display measured variables (e.g. temperature or pressure) in standardized pneumatic signals from 0.2 to 1 bar.

The devices are fitted with double or quadruple indicators depending on the control task. Devices with electric or pneumatic limit contacts have proximity switches or pick-offs with emitter sensor nozzles, which are connected to the limit contact pointers. The metal tag connected to the measuring unit pointer triggers a signal when a limit is reached. See ► T 7526.

i Note

The listed limit contacts are no longer available.

5.5 Type 3417 Pneumatic Control Unit

The Type 3417 Pneumatic Control Unit is used to adjust, link, and feedback pneumatic signals in standardized range from 0.2 to 1 bar.

The set-up of the individual versions varies in the equipment of remote adjusters, signal selector switches, and indicators which are installed in the housing depending on the control task. See ► T 7527.

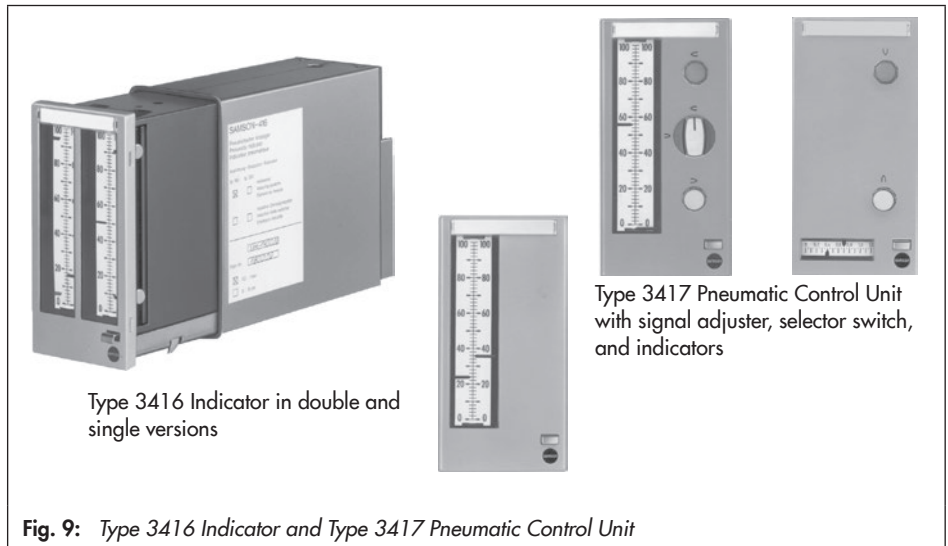

5.6 Type 3423 Controller Modules

See ► T 7521. The controller modules are plug-in units which are inserted onto the self-seal push-on fittings of a manual control station, manual control unit, or control room or field housing. The controller modules are held in place by a screw.

The controller modules consist of a comparator fitted with four metal bellows arranged in a square and a base plate with self-seal push-on fittings.

The base plate accommodates the components required for the chosen function, such as relays and restrictors. The components can be exchanged or upgraded, allowing the function to be changed at a later point in time (see section 9.1).

Type 3423-2 PI Controller (Fig. 10, top)

The controlled variable x and the reference variable w (set point) are transferred as pneumatic signals between 0.2 and 1 bar via turnboard **A** to the metal bellows w and x . When x is greater than w , the controlled variable bellows tilts the pivoted swashplate toward the set point bellows, causing the pressure downstream of the nozzle connected to the swashplate over a pin to rise. As a result, the output pressure y_A of the booster increases. The pressure y_A is fed back immediately via turnboard **B** to the bellows $R2$ onto the swashplate.

The position of the swashplate and the output pressure y_A keep changing until the distance between nozzle and flapper is the same as initially and the output pressure y_A

assumes a value corresponding to the controlled variable x and the adjusted proportional-action coefficient K_p adjustable over a screw.

Outside of the controller module, the y_A is connected to **R**, allowing the pressure y_A to be fed back to bellows $R1$ also over the port **R** and the adjustable T_n restrictor. As a result, the effects of the pressures in bellows $R1$ and $R2$ balance themselves out and the error deviation is eliminated.

A switchover to manual mode at the controller station causes a switching pressure to be applied to port **S**. The T_n start-up relay is activated and bypasses the T_n restrictor.

The **turnboard A** determines the direction of action of the controller. The direction of action can be changed by turning the turnboard (see section 3.1.1).

The **turnboard B** determines the air delivery to the feedback bellows.

In the delivered state, the turnboard **B** is set to y_A , i.e. the output pressure y_A is directly fed back to bellows $R2$. Whereas, it is fed via connection **R** to bellows $R1$. With this circuit arrangement, the controller provides normal air delivery and output pressure damping.

In the switching position to **R**, the output pressure y_A is fed back via port **R** to the bellows $R1$ and $R2$. As a result, the controller has a higher air delivery. Practical application for long distances to the control valve, large connecting volumes and for fast controlled systems.

See section 3.1.2 on how to set or change the air delivery by turning the turnboard **B**.

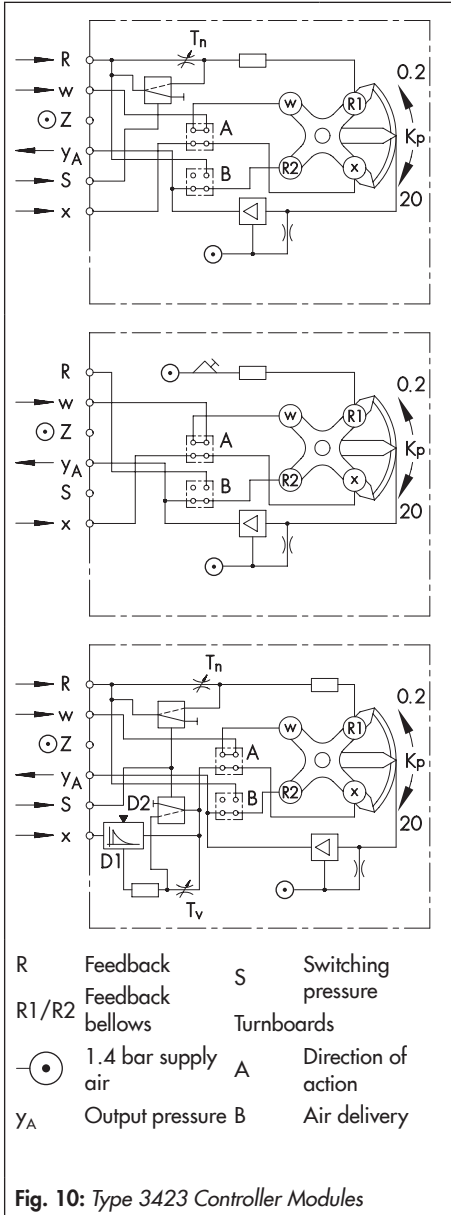

Design and principle of operation

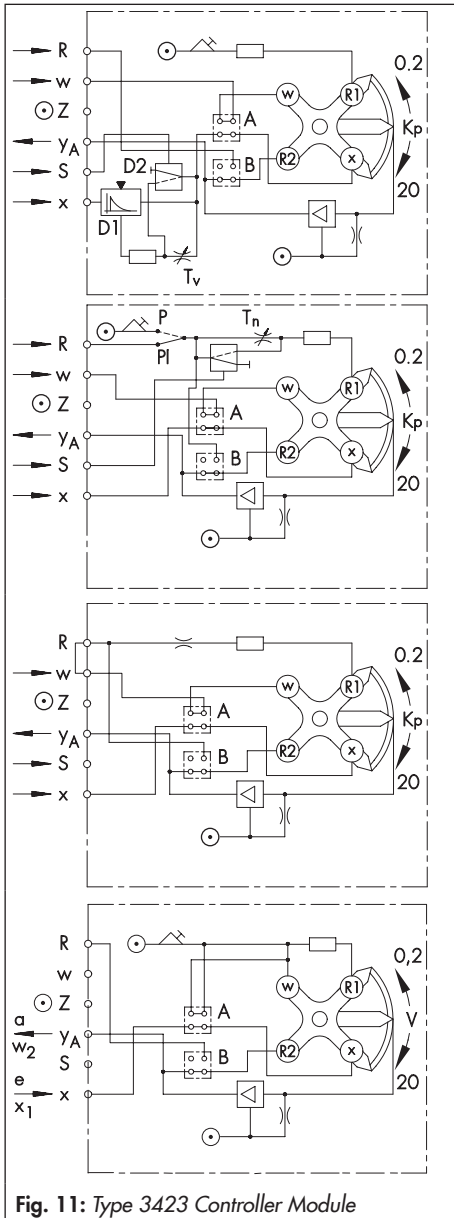

The **Type 3423-4 PD Controller Module** is similar to Type 3423-4.

This module, however, contains a derivative element providing a rate gain of the input branch of the controlled variable x . It has a derivative-action gain of approx. ten times and a derivative-action time that can be adjusted at the TV restrictor.

The **Type 3423-5 P/PI Controller Module** with P/PI selector switch can be used either as P controller with operating point setting or PI controller.

This module is designed in the same way as the PI and P controller modules.

The **Type 3423-6 PD/PID Controller Module** with PD/PID selector switch can be used either as PD or PID controller.

The **Type 3423-9 P Controller Module** with set-point-dependent operating point is the same as Type 3423-1 P Controller Module, except the operating point changes proportionally to the set point w .

Type 3423-7 Ratio Relay

This device is designed as the Type 3423-1 P Controller Module. The constant pressure of the operating point adjuster, however, is fed to the R1 and w bellows. The output pressure a is proportional to the input pressure e ($a = e \times K_p$). In ratio control applications, this pressure is the reference variable for a slave controller.

The ratio $V = a/e$ is adjusted in the same way as the proportional-action coefficient K_p (gain) for P controllers.

5.7 Additional modules

i Note

The Type 3424 Additional Module is no longer available.

The additional modules upgrade the control equipment especially concerning processing engineering requirements. They are mounted between the controller module and the controller module assigned to the connector strip.

5.7.1 Type 3424-2x for i/p conversion

See ► T 7523. The i/p additional module is used to link electric systems to the manual control station. It is used to convert a standardized 4 to 20 mA DC signal into a standardized pneumatic signal from 0.2 to 1 bar.

The i/p converter, which functions according to the force-balance principle, is mounted directly to the controller module of the Type 3421 Compact Controller (Type 3424-21) or to the Type 3422 Manual Control Station (Type 3424-20).

In the delivered state, the output pressure is either connected to the signal channel of the controlled variable x or to the external reference variable w_{ext} depending on the order specifications.

The Type 3424-2 i/p Converter is no longer available. Instead, the external mounting of a Type 6111, 6116 or 6126 i/p Converter is possible. Further details are available on request.

Type 3424-23

mounted onto Type 3423-2 Controller Module



Type 3424-21

with terminal plate for pneumatic self-seal push-on fittings



Type 3424-4 Manual/automatic Transfer



Fig. 12: Type 3424-2x and Type 3424-4 Additional Modules

5.7.2 Type 3424-4 for bumpless manual/automatic switchover

A bumpless transfer from manual to automatic mode is only possible when the controller output pressure y_A and the manual output pressure y_H are the same. The transfer from y_A to y_H is performed manually in most instruments.

The Type 3424-4 Additional Module connected between controller and manual control station performs this switchover automatically.

The module can be equipped optionally with a pressure limiter. This limits the controller output pressure y_A to the maximum pressure adjusted.

5.7.3 Type 3424-5 for control mode changeover

The control mode changeover switches the connected controller from PI or PID to P action if the control error exceeds an adjustable limit. This allows a fast start-up of the set point without overshooting.

5.7.4 Type 3424-6 for signal limitation

The additional module is used to limit the maximum and minimum controller output pressure y_A , the feedback signal R or the reference variable w .

More details on Type 3424-4 Manual/automatic Switchover, Type 3424-5 Control Mode Changeover, and Type 3424-6 Signal Limiter can be found in Data Sheet ► T 7524.

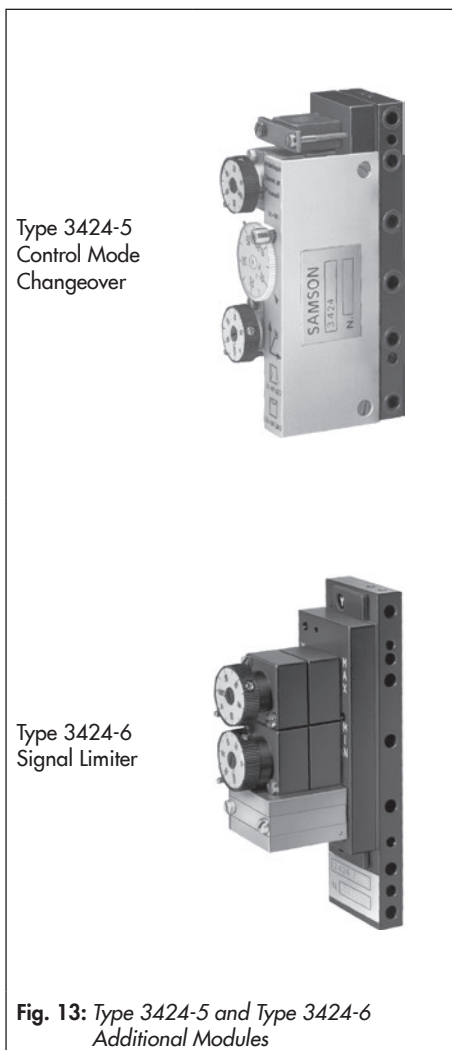

Fig. 13: Type 3424-5 and Type 3424-6 Additional Modules

5.8 Optional electrical limit contacts

i Note

The listed limit contacts and LEDs are no longer available.

The limit contacts indicate when the controlled variable x falls below and/or exceeds an adjustable limit.

The version with **inductive limit contacts** has a controlled variable pointer fitted with metal tags which move adjustable proximity switches within a magnetic field.

The operation of the inductive limit contacts requires switching amplifiers in accordance with EN 60947-5-6 to be connected in the output circuit.

The corresponding wiring (Fig. 17) allows the limit contacts to be additionally fitted with LEDs.

Internal electrical limit contacts with LED are amplified on the internal board and only used to actuate LEDs. These contacts require a 24 V DC power supply.

See section 3.2 on how to adjust the limit contacts.

6 Installation

Panel-mounted devices (Type 3421, Type 3422, Type 3427, Type 3416, and Type 3417)

All devices have the front dimensions 72 x 144 mm and require a control panel cut-out of 138⁺¹ x 68^{+0.7} mm.

The devices are fastened at the top and bottom to a rail (Type 3421/3422: 1089-0036 and Type 3427: 1089-0037) in the control panel.

The tightening torque for the screws depends on the installation situation (approx. 1.4 Nm). On tightening the screws, the rail must have direct contact with the housing and the panel must not be bent.

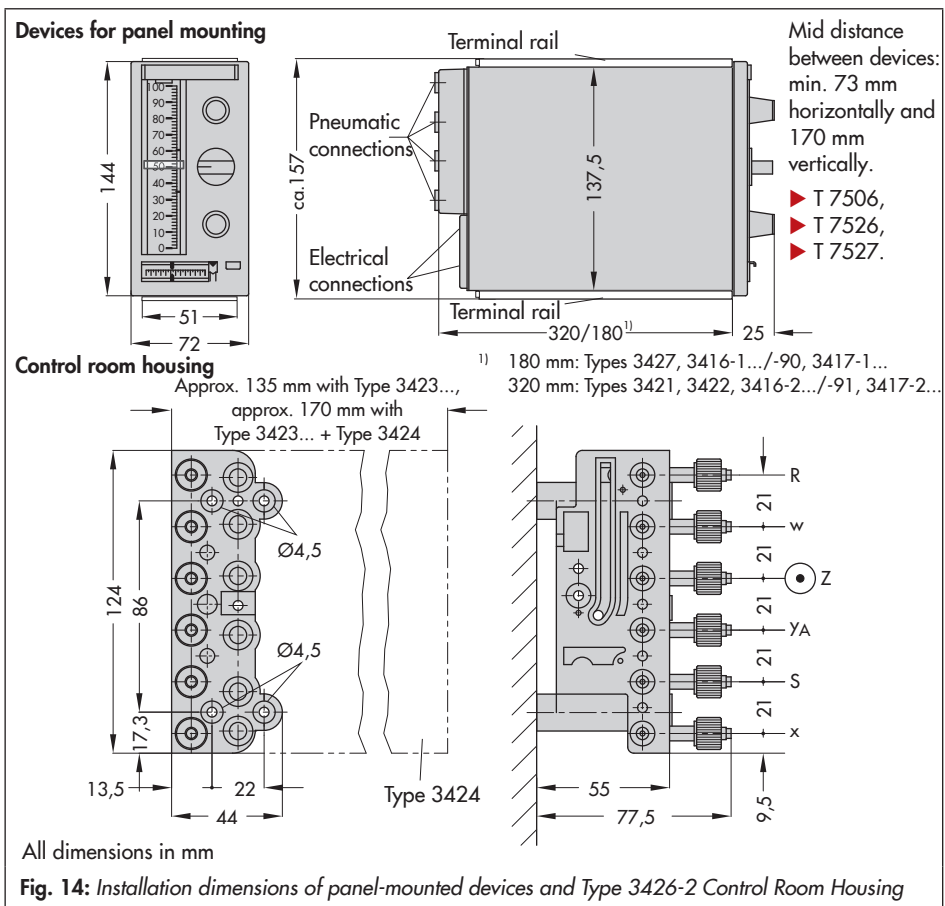

Type 3426 Control Room or Field Housing
 Fasten control room housing (Type 3426-2) using M4 screws in the control room.
 Fasten the field housing (Type 3426-3) using brackets to a wall.

Type 3423 Controller Modules and Type 3424 Additional Modules
 Push the controller and additional modules into the self-seal push-on fittings and screw them tight.

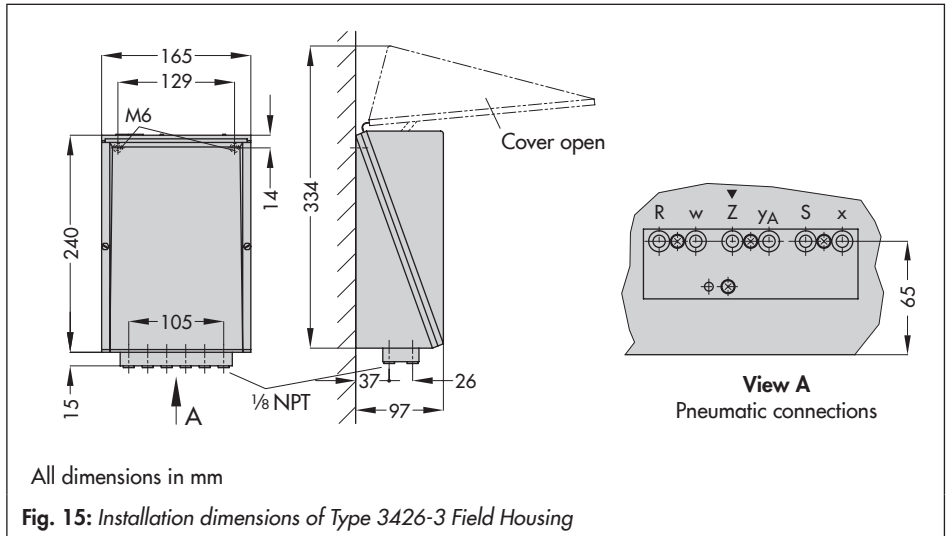

6.1 Changing scales

The large scales for the manual control stations, pneumatic indicators, and pneumatic control units can be replaced with other scales.

To replace or turn the scales, proceed as follows:

1. Release lock and pull out the plug-in unit.
2. Reach into the top opening and pull up the scale holder. Bend the scale slightly and pull it out.
3. Turn scale or replace it with another one and insert it into the scale holder.
4. Insert scale holder into its guide and push it into place.

7 Connections

7.1 Pneumatic connections

The pneumatic connections are designed as a bore with $\frac{1}{8}$ NPT thread. Customary fittings for tubing or plastic hoses can be used.

! NOTICE

Make sure the supply air is dry as well as free of oil and dust.

Read the maintenance instructions for up-stream pressure reducing stations.

Blow through all air pipes and hoses thoroughly before connecting them.

The threaded holes on the connecting plate (depending on the type and circuit version) which are not used must be sealed with stoppers with $\frac{1}{8}$ NPT thread.

The port labeling is as follows:

- S Switching pressure** (0/1.4 bar)
Sealed in Type 3422 Manual Control Station, open in Type 3427 Pneumatic Manual Control Unit when used with controller for control room or field installation (except with P and V controller module)
Output in Type 3427, input in Types 3423 and 3425.

On switching the manual control station to **manual**, a switching pressure of 1.4 bar is applied to the start-up relay to bypass the Tn and Tv restrictors.

- yA Automatic output pressure** (0.2 to 1 bar)

Sealed in Type 3422, open for separate instrumentation with Type 3427 Pneumatic Manual Control Unit

Output in Types 3423 and 3425, input in Type 3427.

- w Reference variable** (0.2 to 1 bar)
Sealed in Type 3422, open in Type 3427.

Output in Type 3427, input in Types 3423 and 3425.

- Z Supply air** \odot
Supply air 1.4 \pm 0.1 bar.

- R Feedback** (input 0.2 to 1 bar)
Sealed in Type 3422 in delivered state (**R** and **y** are internally connected on the connecting plate).

If **R** and **y** ports are to be connected externally (Fig. 16, top), unfasten the connecting plate and move the O-ring to the feedback port (**y** and **R** are then separated from one another). Remove the stopper at the **R** port and replace it with a screw fitting.

- w_{ext} External reference variable** (input 0.2 to 1 bar)
To feed forward the reference variable externally when selector switch is set to w_{ext}

- x Controlled variable** (input 0.2 to 1 bar)
Input signal, output signal from transmitter

- y** **Manipulated variable** (0.2 to 1 bar)
Controller output signal to actuate the control valve
Output in Type 3427, input in Types 3423 and 3425.

Zul Supply air

Ports 1, 2, 3, 4

In Type 3416 Indicator and Type 3417 Pneumatic Control Unit. Assignment depending on version.

Type 3416-90/91 Indicators with pneumatic limit contacts have ports designed as connecting grommets for a 1.8x1 hose.

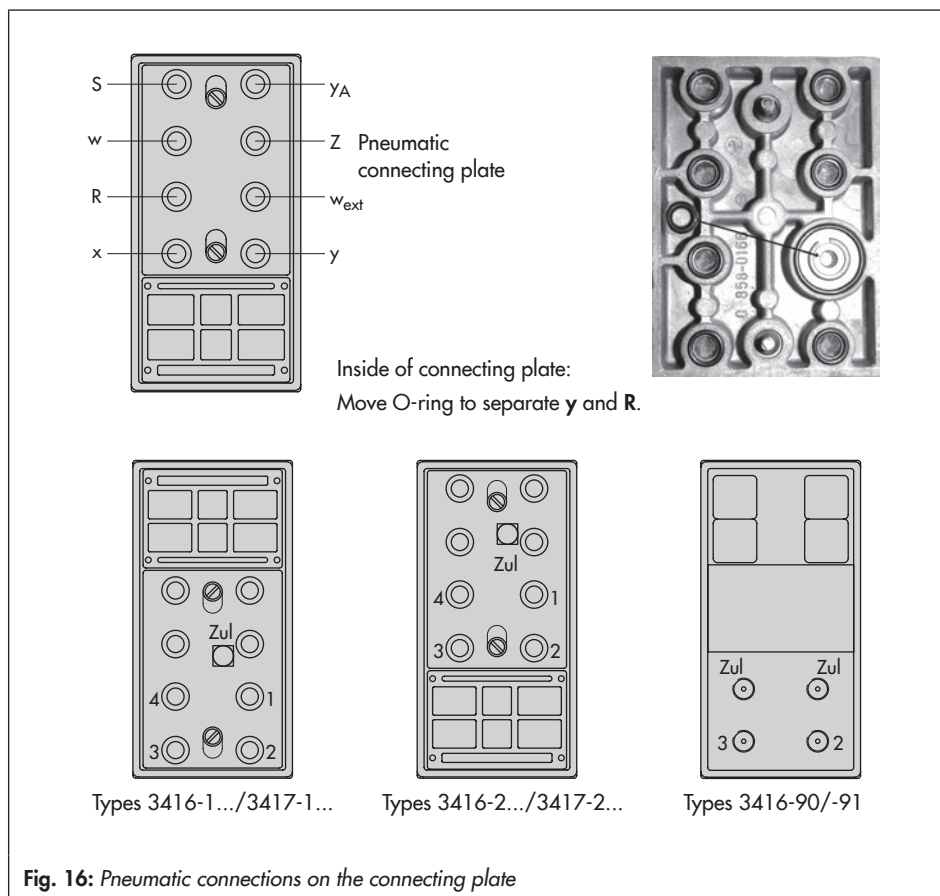

Fig. 16: Pneumatic connections on the connecting plate

7.2 Electrical connections

NOTICE

For electrical installation, observe the relevant electrotechnical regulations and the accident prevention regulations that apply in the country of use.

In Germany, these are the VDE regulations and the accident prevention regulations of the employers' liability insurance.

Note

The listed limit contacts, LEDs, and i/p converters are no longer available.

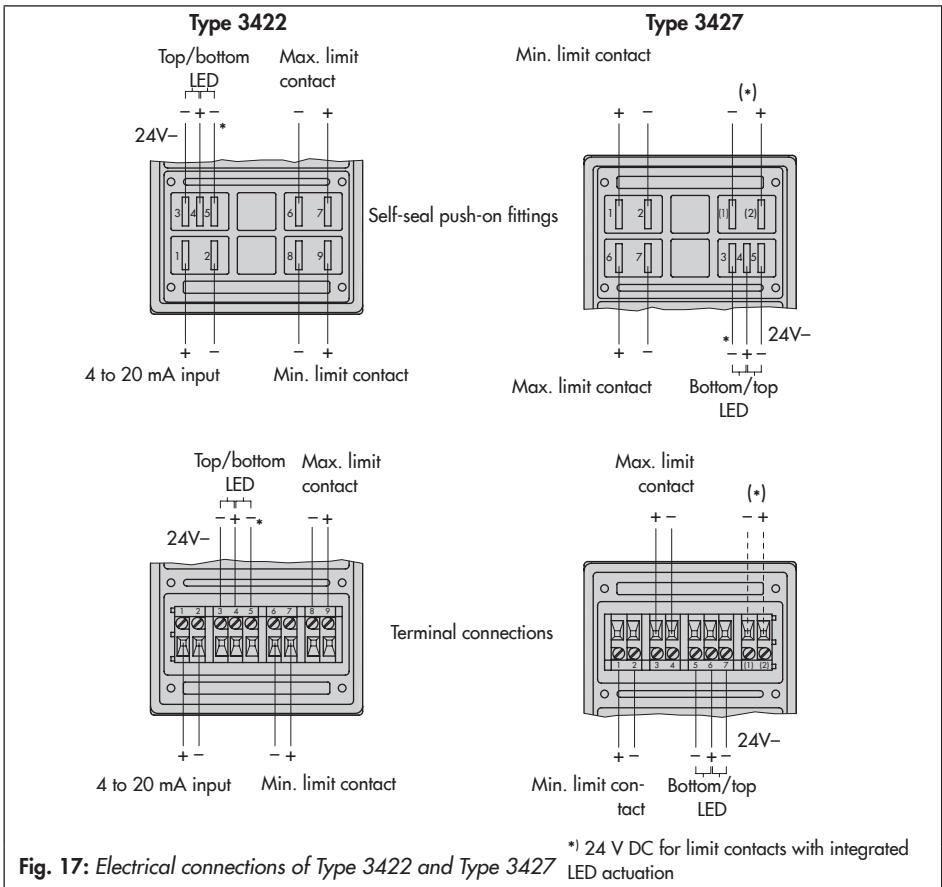

Fig. 17: Electrical connections of Type 3422 and Type 3427

Electrical connection only applies to devices with additional i/p modules or electrical equipment, such as limit contacts or LEDs. Fast-on connectors (6.3 mm socket) or terminals are used depending on the version. The

operation of the inductive limit contacts requires switching amplifiers in accordance with EN 60947-5-6 to be connected in the output circuit.

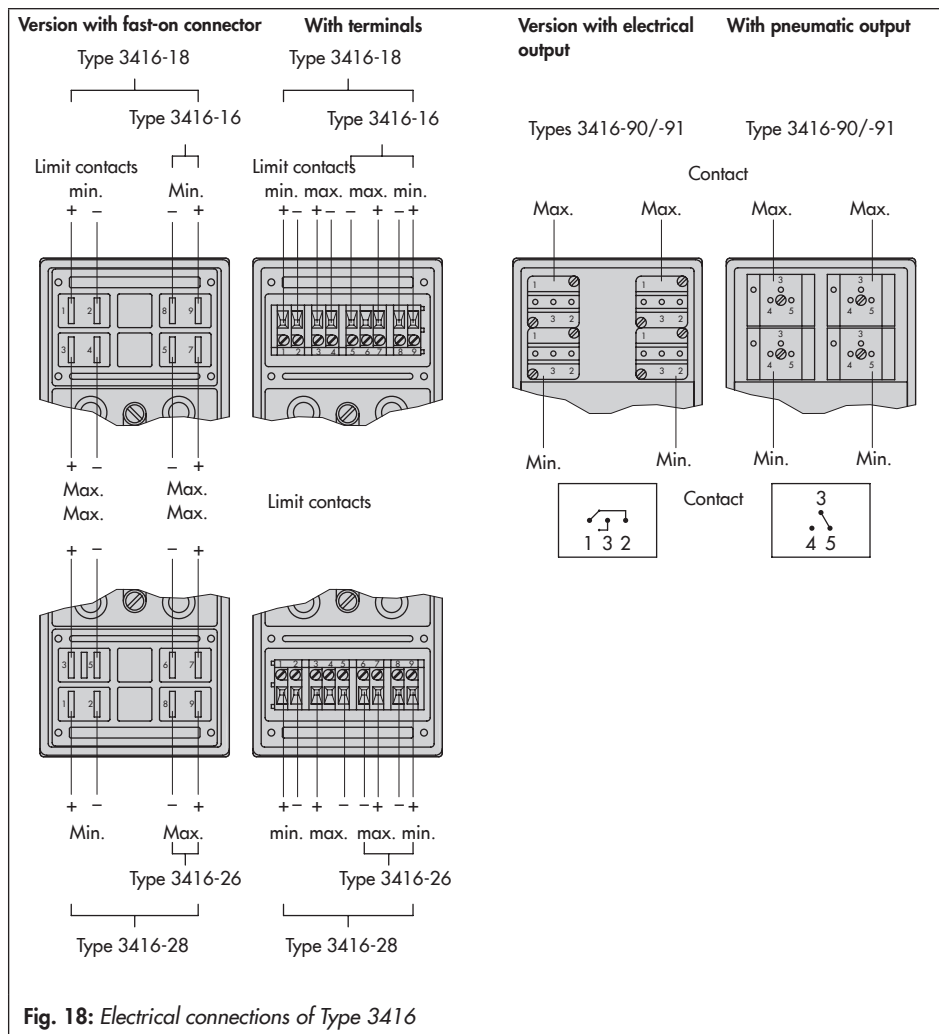

Fig. 18: Electrical connections of Type 3416

8 Maintenance

8.1 Checking the air supply

The modules of the pneumatic controllers normally do not require any maintenance. However, the air supply must be checked at regular intervals.

To guarantee trouble-free operation of the device, make sure that the supply air is always clean.

Check the air filter and separator installed in the upstream air reducing station regularly. If necessary, if the performance worsens, clean or replace the appropriate filters.

If a controller module does not control properly or the output signal is missing, unscrew the restriction with filter (7 in Fig. 2 and Fig. 19) located on left-hand side underneath the comparator. It may be necessary to unscrew and clean the filter or to replace it (order no. 0550-0183).

In addition, all the ports have filters with plastic rims (order no. 0550-0189) on the back connecting plate of the devices. These filters can be unscrewed and removed for cleaning.

The self-seal push-on fittings of the controller modules are also fitted with filters. They cannot be renewed.

9 Conversion

9.1 Changing the controller function

If a different control behavior is necessary, for example, after modifying the plant, the control behavior of the Type 3423 Controller Module can be altered by converting or upgrading components, such as adjusters, restrictors or a derivative amplifier.

The required parts are listed in Table 1 on page 32.

1. Unscrew the fastening screw (6) at the controller module and pull the module off its self-seal push-on fittings. Lift it out of the control station (control room or field housing).
2. Unscrew screws (3.3) and pull off the connecting plate (3.2) together with square nuts and bolts from the controller module.
3. Unscrew inside M3 hexagon socket screws. Remove and/or install the cover plates and adjusters as described below depending on the version.
4. **P to PI:** Remove adjuster for operating point (12) and replace it with Tn restrictor (10).

P to P/PI: Remove adjuster for operating point (12) and replace it with selector switch with adjuster for operating point (13) and Tn restrictor (10).

P to PD: Unscrew cover plate (14.1). Remove formed seal (14.3) and insert two O-rings (14.4) in its place. Fasten deriv-

ative amplifier (14) in place. Unscrew cover plate (11.1) and mount Tv restrictor (11).

PI to PID: Same as for P to PD.

P to PID: Same as for P to PD. In addition, replace adjuster (12) with Tn restrictor (10).

P controller with set-point-dependent operating point: Attach plate with restriction

(15) in place of the adjuster for operating point (12).

Note

We recommend replacing old O-rings with new ones as well as replacing the filter in the restriction (7 in Fig. 1 and Fig. 19).

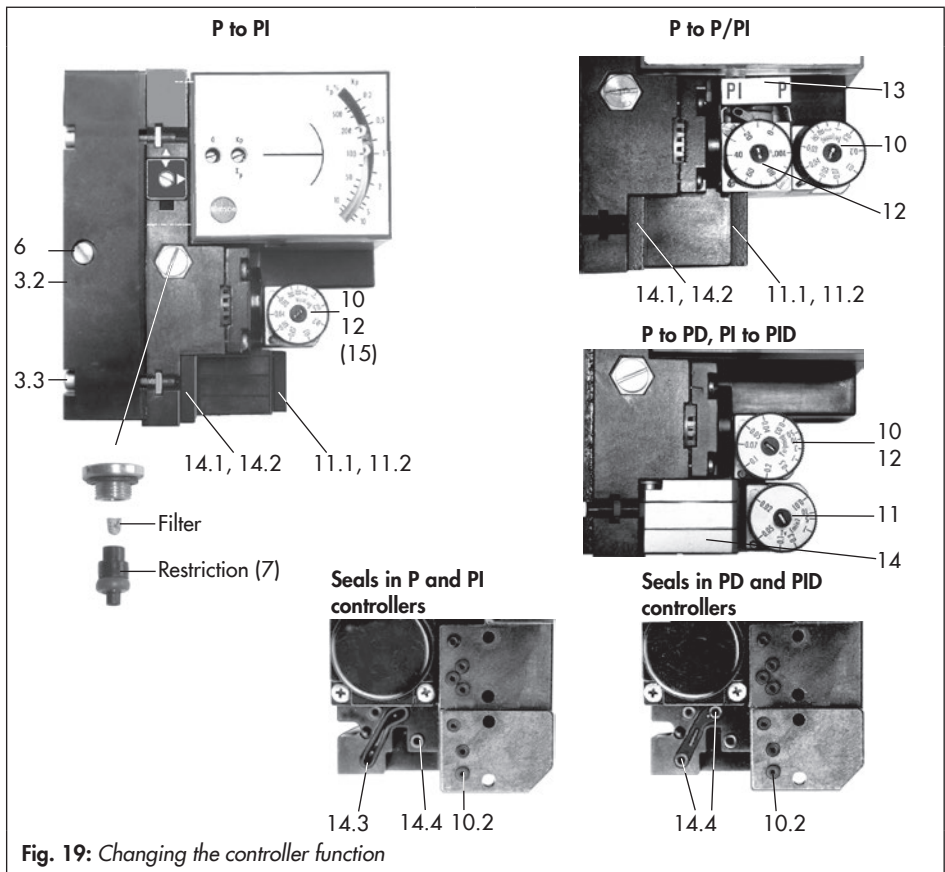

Fig. 19: Changing the controller function

Conversion

Table 1: *Spare parts*

Part	Qty.	Designation	Order no.
7	1	Restriction with filter	1390-0183
	8	Filter in the connecting plate of the manual control unit	0550-0189
10	1	Tn restrictor	1070-4584
10.1	2	M3 x 6 screws	8333-0476
10.2	3	O-rings 1.78 x 1.02	8421-0010
11	1	Tv restrictor	1070-4585
11.1	1	Cover plate	0360-1597
11.2	2	M3 x 8 screws	8333-0479
11.3	4	O-rings 2 x 1.5	8421-0023
12	1	Operating point adjuster 1.4 bar	1070-7550
12	1	Operating point adjuster 20 psi	1070-7551
12.1	2	M3 x 8 screws	8333-0479
12.2	4	O-rings 1.78 x 1.02	8421-0010
13	1	Selector switch for operating point adjuster	1080-6909
13.1	2	M3 x 30 screws	8333-0482
13.2	4	O-rings 1.78 x 1.02	8421-0010
14	1	Derivative amplifier	1080-6924
14.1 ¹⁾	1	Cover plate	0360-1598
14.2	1	M3 x 16 screw	8333-0476
14.3 ¹⁾	1	Formed seal for plate	0430-0992
14.4	4 (2)	O-rings 2 x 1.5	8421-0023
15	1	Plate with restriction for set-point-dependent operating point	1590-1089

¹⁾ Required for P and PI controller. Not required for PD and PID controller.

9.2 Operating mode change-over in Type 3424-2 i/p Converter

The i/p module is in the x input in x mode and in the w_{ext} input in w_{ext} mode.

1. Release lock and completely pull out the plug-in unit.
2. Pull the three-pin cable connector for the mA signal off the converter board.
3. Unscrew the fastening screw (6) at the controller module and pull the module off together with the i/p converter from the self-seal push-on fittings. Lift it out of the control station.
4. Pull the three-pin cable connector for the mA signal off the terminal plate.
5. Swap the location of the O-ring and washer on the holes on the inside of the plate as shown in Fig. 20.

x mode

6. Seal tight the w_{ext} input of the compact controller connecting plate (Fig. 16) with a screw plug with $\frac{1}{8}$ NPT thread.

The w_{ext} port at the plug connection of the control station must be sealed.

w_{ext} mode

7. Open the w_{ext} port at the plug connection by unscrewing the M4 hexagon socket screw at the w_{ext} port and insert 4 x 2 O-ring included.

Seal tight the w_{ext} input of the compact controller connecting plate (Fig. 16) with the $\frac{1}{8}$ NPT screw.

8. Reinstall converter and plug on the cable connector.

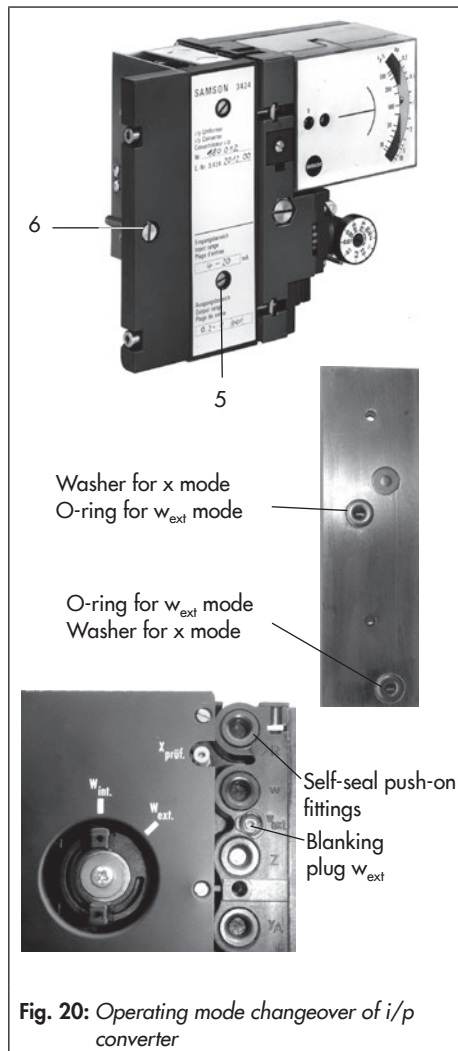

9.3 Checking the controller function

To check the controller, the controlled variable **x** and the output **y** must be bypassed at ports **x** and **y** on the controller station.

Perform the following settings:

- Turnboard **A** to increasing/decreasing >
<,
 - Fully open Tn restriction (0.03 min),
 - Fully close Tv restriction (0.01 min).
- ➔ Turn the set point rotary knob to change the reference variable through its whole range.

The controlled variable pointer (red) and the output reading (small dial) follow the reference variable over the whole range when the controller functions properly.

10 Technical data

Type 3421 Compact Controller								
Type 3422 Manual Control Station								
Circuit	1 and 2						9	
Set point/ controlled variable display	Measuring range 0.2 to 1.0 bar (3 to 15 psi) · Accuracy class 1 (synchronism 0.6) · Scale 0 to 100 %, (linear, square root or special inscription) · Scale length 100 mm							
Output display	Output 0 to 1.2 bar (0 to 18 psi) · Accuracy class 2.5 × Scale: 0 to 1.2 bar (0 to 18 psi), length 36 mm							
Adjuster for manual mode	Output 0.2 to 1.0 bar (3 to 15 psi) · Max. 0.02 to 1.35 bar Max. air delivery >1.5 m _n ³ /h · Air consumption depending on adjuster: 0.1 m _n ³ /h							
Limit contacts ³⁾	1 or 2 adjustable limit contacts with proximity switch SJ 3,5-N-Y according to EN 60947-5-6							
Type 3422 Manual Control Station equipable with ...								
Type ... Module	3423-1	3423-2 ¹⁾	3423-3 ¹⁾	3423-4	3423-5	3423-6	3423-9	3423-7
Controller action	P	PI	PID	PD	P/PI	PD/PID	P ²⁾	Ratio module
Control parameters	Proportional-action coefficient K _p = 0.2 to 20 or 0.4 to 40 Reset time T _n = 0.03 to 50 min Derivative-action time T _v = 0.01 to 10 min Derivative-action gain of x »10 Operating point adjustment: 0.2 to 1.0 bar (3 to 15 psi)							Ratio R = a/e mechanically adjustable, R = 0.2 to 20
Input	0.2 to 1 bar (3 to 15 psi)							
Output	0.2 to 1 bar (3 to 15 psi), max. 0.02 to 1.35 bar (0.3 to 19 psi) max. air delivery: >1.5 m _n ³ /h · Air delivery with yA setting: approx. 1 m _n ³ /h per % of the system deviation · With R setting: approx. 3 m _n ³ /h per % of the system deviation							
Air consumption in steady state in m _n ³ /h	<0.1	<0.05	<0.13	<0.1	<0.05	<0.05	<0.05	<0.1
Alignment offset	<0.5 %							Hysteresis <0.4 % (1 % at R >2)
Tracking error	<0.5 %							Deviation from terminal-based linearity <1 % (0.4 % at V = 0.5 to 2)
Dead band	<0.01 %							
Derivative element	Deviation of controlled variable x: <1 %							
Influence of supply air at 1.4 ±0.1 bar	<±0.1 % (D element additionally: <±0.2 %)							<±1 % (<±0.4 % at V <2)
Temperature influence/K	<0.01 % (D element additionally: <0.01 %)							<0.05 % (<0.02 % when V = 0.5 to 2)

¹⁾ Optionally with maximum feedback limitation

²⁾ With set-point-dependent operating point

³⁾ No longer available

Technical data

Type 3424-2 ... Additional Module ¹⁾	i/p converter, 4 to 20 mA or 0 to 20 mA input, 0.2 to 1 bar (3 to 15 psi) output Input impedance approx. 200 Ω and 4 mH
Type 3424-4	Manual/automatic transfer Input: 0.2 to 1.0 bar (3 to 15 psi) Output: 0.2 to 1.0 bar (3 to 15 psi), max. 0.02 to 1.35 bar (0.3 to 19 psi)
Type 3424-5	Control mode changeover · Output: switching pressure approx. 1.4 bar (only for Types 3423-2/-3)
Type 3424-6	Signal limiter for yA, R or w · Limitation adjustable between 0.2 and 1.0 bar (3 and 15 psi)
Supply air	Supply air 1.4 ±0.1 bar (20 ±1.5 psi) · Air consumption per unit <0.15 m _n ³ /h
Medium for supply air and inputs	Instrument air, free from corrosive substances
Air quality acc. to ISO 8573-1: 2001	Max. particle size and density: Class 3 · Oil content: Class 2 · Pressure dew point: Class 3 or at least 10 K below the lowest ambient temperature to be expected
Permissible ambient temperature range	-20 to +60 °C
Compliance	CE · ENEC
Weight (approx.)	Manual control station (without components): 2.5 kg · Type 3421 with controller module: 3.2 kg Type 3421 Controller with controller or additional module: 3.6 kg

¹⁾ No longer available

Technical data for the devices can be found in the following data sheets:

Device designation (Type)	Further details in data sheet
Type 3421 Pneumatic Compact Controller	▶ T 7506
Type 3422 Manual Control Station	▶ T 7506
Type 3427 Manual Control Station	▶ T 7511
Type 3425 Pneumatic Controller (wall-mounted and field controller)	▶ T 7512
Type 3416 Indicator	▶ T 7526
Type 3417 Pneumatic Control Unit	▶ T 7527
Types 3423-1/-2/-3/-4/-5/-6/-7/-9 Controller Modules	▶ T 7521
Types 3424-4/-5/-6 Additional Modules	▶ T 7524
Type 3424-2 Additional Module	▶ T 7523

EB 7500 EN



SAMSON AKTIENGESELLSCHAFT
Weismüllerstraße 3 · 60314 Frankfurt am Main, Germany
Phone: +49 69 4009-0 · Fax: +49 69 4009-1507
samson@samson.de · www.samson.de