

MOUNTING AND OPERATING INSTRUCTIONS



EB 2519 EN

Translation of original instructions



Pressure limiters (PL) with a Type 2401-2 Pressure Element and safety pressure limiters (SPL) with a Type 2401-1 Pressure Element
For mounting on self-operated regulators

Edition June 2022



Note on these mounting and operating instructions

These mounting and operating instructions assist you in mounting and operating the device safely. The instructions are binding for handling SAMSON devices. The images shown in these instructions are for illustration purposes only. The actual product may vary.

- For the safe and proper use of these instructions, read them carefully and keep them for later reference.
- If you have any questions about these instructions, contact SAMSON's After-sales Service (aftersaleservice@samsongroup.com).



Documents relating to the device, such as the mounting and operating instructions, are available on our website at www.samsongroup.com > **Service & Support > Downloads > Documentation.**

Definition of signal words

DANGER

Hazardous situations which, if not avoided, will result in death or serious injury

WARNING

Hazardous situations which, if not avoided, could result in death or serious injury

NOTICE

Property damage message or malfunction

Note

Additional information

Tip

Recommended action

1	Safety instructions and measures	5
1.1	Notes on possible severe personal injury	7
1.2	Notes on possible personal injury	7
1.3	Notes on possible property damage	8
2	Markings on the device	9
2.1	Nameplate of the pressure element	9
2.2	Valve nameplate	9
3	Design and principle of operation	10
3.1	Versions	10
3.2	Technical data	12
4	Measures for preparation	15
4.1	Unpacking	15
4.2	Transporting and lifting	15
4.2.1	Transporting	16
4.2.2	Lifting.....	16
4.3	Storage.....	17
4.4	Preparation for installation.....	17
5	Mounting and start-up	18
5.1	Mounting the pressure limiter on the valve.....	18
5.2	Mounting the safety pressure limiter onto the valve	19
5.3	Connecting the capillary tube.....	20
5.4	Installing the valve into the pipeline	20
5.4.1	Mounting orientation.....	20
5.4.2	Additional fittings.....	21
5.4.3	Installing the valve.....	21
6	Operation	22
6.1	Adjusting the limit	22
6.2	Unlocking after a fault	23
6.2.1	Unlocking the pressure limiter	23
6.2.2	Unlocking the safety pressure limiter	23
7	Servicing	24
7.1	Preparation for return shipment.....	24
7.2	Ordering spare parts and operating supplies	24

8	Decommissioning and removal	25
8.1	Decommissioning.....	25
8.2	Removing the valve from the pipeline.....	25
8.3	Disposal.....	26
9	After-sales service	26
10	Certificates.....	27

1 Safety instructions and measures

Intended use

The pressure limiter (PL) with Type 2401-2 Pressure Element and safety pressure limiter (SPL) with Type 2401-1 Pressure Element are used to limit the maximum pressure in heat generators or heat exchangers by closing and locking a mounted valve. When equipped with a type-tested control thermostat or safety thermostat, the device is also used to limit the temperature.

The device is designed to operate under exactly defined conditions (e.g. operating pressure, process medium, temperature). Therefore, operators must ensure that the device is only used in operating conditions that meet the specifications used for sizing the device at the ordering stage. In case operators intend to use the device in applications or conditions other than those specified, contact SAMSON.

SAMSON does not assume any liability for damage resulting from the failure to use the device for its intended purpose or for damage caused by external forces or any other external factors.

→ Refer to the technical data and nameplate for limits and fields of application as well as possible uses.

Reasonably foreseeable misuse

The device is not suitable for use outside the limits defined during configuration and by the technical data. Furthermore, the following activities do not comply with the intended use:

- Use of non-original spare parts
- Performing service and repair work not described

Qualifications of operating personnel

The device must be mounted, started up, serviced and repaired by fully trained and qualified personnel only; the accepted industry codes and practices must be observed. According to these mounting and operating instructions, trained personnel refers to individuals who are able to judge the work they are assigned to and recognize possible hazards due to their specialized training, their knowledge and experience as well as their knowledge of the applicable standards.

Safety instructions and measures

Personal protective equipment

We recommend checking the hazards posed by the process medium being used (e.g.

▶ GESTIS (CLP) hazardous substances database).

- Provide protective equipment (e.g. safety gloves, eye protection) appropriate for the process medium used.
- Check with the plant operator for details on further protective equipment.

Revisions and other modifications

Revisions, conversions or other modifications of the product are not authorized by SAMSON. They are performed at the user's own risk and may lead to safety hazards, for example. Furthermore, the product may no longer meet the requirements for its intended use.

Warning against residual hazards

To avoid personal injury or property damage, operators and operating personnel must prevent hazards that could be caused in the device by the process medium and operating pressure by taking appropriate precautions. Plant operators and operating personnel must observe all hazard statements, warning and caution notes in these mounting and operating instructions, especially for installation, start-up and service work.

We also recommend checking the hazards posed by the process medium being used (e.g.

▶ GESTIS (CLP) hazardous substances database).

- Observe safety measures for handling the device as well as fire prevention and explosion protection measures.

Responsibilities of the operator

Operators are responsible for proper use and compliance with the safety regulations. Operators are obliged to provide these mounting and operating instructions as well as the referenced documents to the operating personnel and to instruct them in proper operation. Furthermore, operators must ensure that operating personnel or third parties are not exposed to any danger.

Responsibilities of operating personnel

Operating personnel must read and understand these mounting and operating instructions as well as the referenced documents and observe the specified hazard statements, warnings and caution notes. Furthermore, operating personnel must be familiar with the applicable health, safety and accident prevention regulations and comply with them.

Referenced standards, directives and regulations

The devices comply with the requirements of the European Pressure Equipment Directive 2014/68/EU. Devices with a CE marking have an EU declaration of conformity, which includes information about the applied conformity assessment procedure. The EU Declaration of Conformity is available on request.

Referenced documentation

The mounting and operating instructions of the mounted valve apply in addition to these mounting and operating instructions.

1.1 Notes on possible severe personal injury

DANGER

Risk of bursting in pressure equipment.

The valve and pressure element are pressure equipment. Improper opening can lead to device components bursting.

In the installed state, the spring in the operating element is preloaded. Incorrect dismantling will release a high amount of energy, which may lead to serious injury.

- Do not dismantle the device.
- Contact SAMSON's After-sales Service for support concerning maintenance or repair work or when malfunctions or defects arise (see section 9).

1.2 Notes on possible personal injury

WARNING

Risk of personal injury due to residual process medium in the valve.

While working on the valve, residual medium can flow out of the valve and, depending on its properties, cause personal injury, e.g. (chemical) burns.

- If possible, drain the process medium from all the plant sections affected and the valve.
- Wear protective clothing, safety gloves and eye protection.

WARNING

Risk of burn injuries due to hot or cold components and pipelines.

Depending on the process medium, valve components and pipelines may get very hot or cold and cause burn injuries.

- Allow components and pipelines to cool down or warm up to the ambient temperature.
- Wear protective clothing and safety gloves.

1.3 Notes on possible property damage

NOTICE

Risk of valve damage due to contamination (e.g. solid particles) in the pipeline.

The plant operator is responsible for cleaning the pipelines in the plant.

- Flush the pipelines before start-up.
- Observe the maximum permissible pressure for valve and plant.

Risk of valve damage due to unsuitable medium properties.

The valve is designed for a process medium with defined properties.

- Only use the process medium specified for sizing the equipment.

Risk of leakage and valve damage due to excessively high or low tightening torques.

Observe the specified torques when tightening valve components.

Excessive tightening torques lead to parts wearing out more quickly. Parts that are too loose may cause leakage.

- Observe the specified tightening torques.

Risk of device damage due to incorrectly attached lifting equipment.

- Do not attach lifting equipment to mounting parts (e.g. capillary tube).

2 Markings on the device

2.1 Nameplate of the pressure element

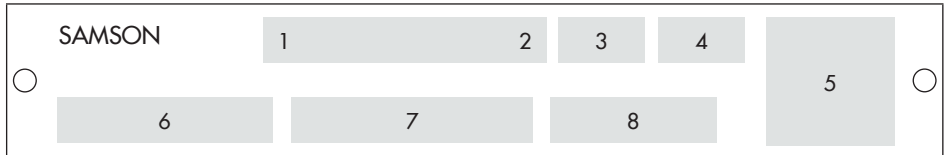

1	Type	5	Unassigned
2	Material no.	6	Size (150/50)
3	Date of manufacture	7	Type test number (TÜV no.)
4	Unassigned	8	Adjustment range of limit value

The nameplate is located on the connecting element (8).

2.2 Valve nameplate

See associated valve documentation.

3 Design and principle of operation

The Type 2401-1 or Type 2401-2 Pressure Element is used in combination with Type 2111, Type 2119 and Type 2422 ¹⁾ Valves to form a pressure limiter (PL) or safety pressure limiter (SPL) respectively.

The Type 2401-1/-2 Pressure Element with its connecting element (8) is connected to the bottom section (4) of the valve using the coupling nut (7).

The medium passes through the strainer (13) and the capillary tube (12) to an operating bellows in the Type 2401-1/-2 Pressure Element (9). It is converted here into a positioning force which is compared to the force of the set point spring.

The spring force depends on the limit adjustment (10). When the pressure reaches the adjusted pressure limit, the spring mechanism in the connecting element (8) is triggered. The spring mechanism moves the pin (6) and the plug stem (5) attached to it, closing and locking the valve (1).

Additionally, the Type 2401-1 Safety Pressure Limiter closes the valve when the measured pressure falls below 0.8 bar (gauge pressure).

The Type 2401-1/-2 Pressure Element can only be reset and put back into operation with a suitable tool (lever with order no. 1490-7399) after the fault has been remedied and the pressure has fallen below the limit.

¹⁾ Formerly Type 2114

Assembly tool

An assembly tool (0230-3752) to mount the safety pressure limiter is included in the scope of delivery.

Type test

The Type 2401-1 and Type 2401-2 Pressure Elements have been tested in conjunction with a valve by the German technical surveillance association TÜV. More details on the type test are available on request.

3.1 Versions

(Safety) thermostat

Additionally, a thermostat or safety thermostat to regulate or limit the temperature can be fitted to the connecting element with spring mechanism (8).

Electric signal transmitter

An additional electric signal transmitter for remote transmission of the plant state can be attached to the operating element with spring mechanism (see section 5.4.2).

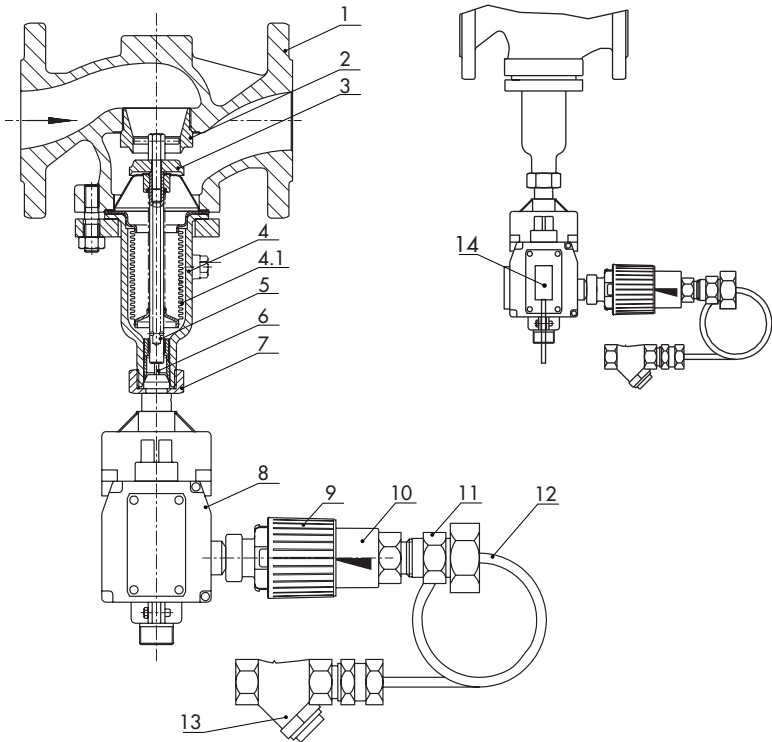

Type 2111, Type 2422 or Type 2119 Valve ¹⁾

- 1 Valve body
- 2 Seat (exchangeable)
- 3 Plug
- 4 Bottom section
- 4.1 Balancing bellows
- 5 Plug stem with spring

Electric additional equipment

- 14 Electric signal transmitter (optional)

Type 2401-1/-2 Pressure Element

- 6 Pin of operating element
- 7 Coupling nut G 1
- 8 Connecting element with spring mechanism
- 9 Type 2401-1 or Type 2401-2 Pressure Element
- 10 Limit adjustment
- 11 Screw fitting with Type 2401-1 or Type 2401-2 Pressure Element
- 12 Capillary tube
- 13 Strainer

Fig. 1: Pressure limiter consisting of valve and Type 2401-1 or Type 2401-2 Pressure Element

3.2 Technical data

The nameplates on the pressure element and valve provide information on the device version. See section 2.1 and the valve documentation.

Table 1: *Technical data · All pressure stated as gauge pressure in bar*

Valves	Type 2111, Type 2119, Type 2422 ¹⁾											
Valve size DN	DN	15	20	25	32	40	50	65	80	100	125	150
Type 2111		Data Sheet ► T 2111						–				
Type 2119		Data Sheet ► T 2133										
Type 2422 ¹⁾		Data Sheet ► T 2121										
Pressure rating		PN 16 to 40										
Type 2401-1/-2 Pressure Element		Size 50 ²⁾						Size 150 ²⁾				
Adjustment range of limit value		1 to 10 bar										
Permissible operating pressure		10 bar										
Permissible ambient temperature		Max. 80 °C										
Permissible operating temperature		200 °C										
Conformity		CE										
Capillary tube length		Approx. 2 m										
Strainer		Type 1 NI, G ½, PN 16 (► T 1010)										
Switching cycles according to DIN EN 14597		500										
Electric signal transmitter Max. load at 230 V (AC)		10 A with resistive load										

¹⁾ Formerly Type 2114

²⁾ Size 50: Type 2401-1/-2 for valve DN 15 to 50 | Size 150: Type 2401-1/-2 for valve DN 65 to 150

Dimensions and weights

Table 2 to Table 4 provide an overview of the dimensions and weights of the different combinations (pressure element and valve). The lengths and heights in the dimensional drawings are shown on page 14.

Dimensions in mm · Weights in kg

Table 2: Type 2422 ¹⁾/2401-1/-2

Port	DN	15	20	25	32	40	50	65	80	100	125	150
Length L		130	150	160	180	200	230	290	310	350	400	480
H1 Without extension With		225						300		355	460	590
		365						440		495	600	730
Weight (PN 16) ²⁾ in kg (approx.)		5	5.5	6.5	13	13.5	16	27	32	40	70	113

¹⁾ Formerly Type 2114

²⁾ +15 % for PN 25/40

Table 3: Type 2111/2401-1/-2

Port	DN	15	20	25	32	40	50	
Length L		130	150	160	180	200	230	
H1 Without extension With		225 ¹⁾ 82 ²⁾			225 ¹⁾ 152 ²⁾			-
		365 ¹⁾						
Weight (PN 16) ¹⁾ in kg (approx.)		4	4.5	5.5	13	13.5	16	

¹⁾ Valve material: 1.0619 and stainless steel

²⁾ Valve material: EN-GJS-400-18-LT, EN-GJL-250

³⁾ +15 % for PN 25/40

Table 4: Type 2119/2401-1/-2

Port	DN	15	20	25	32	40	50	65	80	100	125	150
Length L		130	150	160	180	200	230	290	310	350	400	480
H1 Without extension With		235			245			320		355	395	500
		375			385			460		495	535	640
Weight (PN 16) ¹⁾ in kg (approx.)		6	7	8.5	15	17	19	32	50	71	On request	

¹⁾ +15 % for PN 25/40

Design and principle of operation

Dimensional drawings

Type 2422 ¹⁾/2401-1/-2

Type 2422 ¹⁾/2401-1/-2 · 1.0619, stainless steel

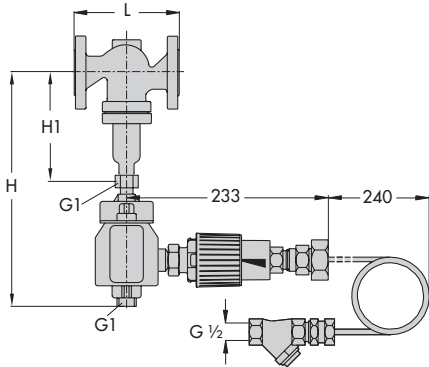

Type 2119/2401-1/-2

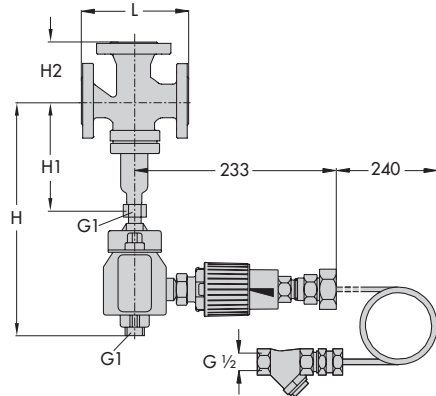

Type 2111/2401-1/-2

EN-GJL-250, EN-GJS-400-18-LT

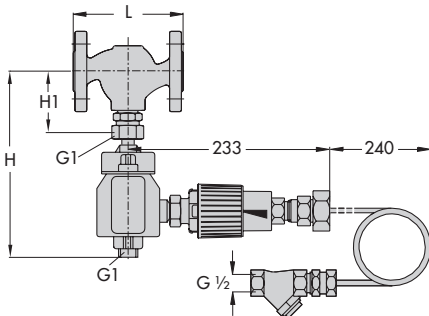

¹⁾ Formerly Type 2114

4 Measures for preparation

After receiving the shipment, proceed as follows:

1. Check the scope of delivery. Compare the shipment received with the delivery note.
2. Check the shipment for transportation damage. Report any damage to SAMSON and the forwarding agent (refer to delivery note).

4.1 Unpacking

Do not remove the packaging until immediately before installing the valve into the pipeline.

Proceed as follows to lift and install the device:

1. Remove the packaging from the device.
2. Dispose of the packaging in accordance with the valid regulations.

4.2 Transporting and lifting

⚠ DANGER

Danger due to suspended loads falling.
Stay clear of suspended or moving loads.

⚠ WARNING

Risk of personal injury due to the device tipping.

- *Observe the device's center of gravity.*
 - *Secure the device against tipping over or turning.*
-

⚠ WARNING

Risk of lifting equipment tipping over and risk of damage to lifting accessories due to exceeding the rated lifting capacity.

- *Only use approved lifting equipment and accessories whose minimum lifting capacity is higher than the weight of the device.*
 - *Refer to section 3.2 or Data Sheet*
▶ T 2519 for weights.
-

ⓘ NOTICE

Risk of valve damage due to incorrectly attached slings.

- *When lifting the device, make sure that the slings attached to the valve body bear the entire load.*
 - *Observe lifting instructions (see section 4.2.2).*
-

4.2.1 Transporting

The device can be transported using lifting equipment (e.g. crane or forklift).

- Leave the device in its transport container or on the pallet to transport it.
- Observe the transport instructions.

Transport instructions

- Protect the device against external influences (e.g. impact).
- Do not damage the corrosion protection (paint, surface coatings). Repair any damage immediately.
- Protect the device against moisture and dirt.
- Observe the permissible ambient temperatures (see section 3.2).

4.2.2 Lifting

To install a large valve into the pipeline, use lifting equipment (e.g. crane or forklift) to lift it.

Lifting instructions

- Secure slings against slipping.
- Make sure the slings can be removed from the valve once it has been installed into the pipeline.
- Prevent the device from tilting or tipping.
- Do not leave loads suspended when interrupting work for longer periods of time.
- Make sure that the axis of the pipeline is always horizontal during lifting and the axis of the plug stem is always vertical.

4.3 Storage

! NOTICE

Risk of device damage due to improper storage.

- Observe the storage instructions.
- Avoid long storage times.

Contact SAMSON in case of different storage conditions or longer storage times.

i Note

We recommend regularly checking the device and the prevailing storage conditions during long storage periods.

Storage instructions

- Protect the device against external influences (e.g. impact).
- Do not damage the corrosion protection (paint, surface coatings). Repair any damage immediately.
- Protect the device against moisture and dirt. Store it at a relative humidity of less than 75 %. In damp spaces, prevent condensation. If necessary, use a drying agent or heating.
- Make sure that the ambient air is free of acids or other corrosive media.
- Observe the permissible ambient temperatures (see section 3.2).
- Do not place any objects on the device.

4.4 Preparation for installation

- Flush the pipelines.

i Note

The plant operator is responsible for cleaning the pipelines in the plant.

- Check the valve to make sure that it is clean.
- Check the valve for damage.
- Check to make sure that the type designation, valve size, material, pressure rating and temperature range of the valve match the plant conditions (size and pressure rating of the pipeline, medium temperature etc.).

5 Mounting and start-up

The Type 2401-1/-2 Pressure Element is installed in the pipeline in combination with a Type 2111, Type 2119, Type 2422 ¹⁾ or Type 2423 Valve to form a Type 2xxx/2401-/-2 Pressure Limiter.

- **Type 2111/2401-1/-2** with Type 2111 Globe Valve
- **Type 2118/2401-1/-2** with Type 2119 Three-way Valve
- **Type 2422/2401-1/-2** with Type 2422 ¹⁾ Globe Valve
- **Type 2423/2401-1/-2** with Type 2423 Globe Valve

The pressure element can also be used in combination with Series 42 Differential Pressure and Flow Regulators.

To connect the actuator (Type 2424, 2427, 2428 or 2429) to the connecting element of the Type 2401-1/-2 Pressure Limiter, a separating piece is required (see Table 5).

→ Before installation, remove the snap ring on the pin of the separating piece.

Table 5: *Separating pieces*

Separating piece · Version	Order no.
Brass · For water	1590-9948
Stainless steel · For water	1590-7703
Stainless steel · For oil	1590-7704

5.1 Mounting the pressure limiter on the valve

The Type 2401-2 Pressure Limiter (PL) and valve are delivered separately and must be fastened together before installing the valve in the pipeline. The tension of the spring mechanism is relieved in the delivered state and the pin (6) of the spring mechanism sticks out of the device. The pressure limiter is locked.

1. Screw the assembly tool (M, 0230-3752) onto the connecting element (8) (see Fig. 2).
2. Clamp the pressure limiter firmly onto the assembly tool (M).
3. Place the lever for unlocking at the pins at the side on the connecting element (8) (see Fig. 3). Pull the lever upward until the spring mechanism is tensioned. The side pins are pushed downward and the spring assembly compressed. The pressure limiter is unlocked.
4. Remove the assembly tool (M).
5. Place on coupling nut (7) and tighten.
6. Connect the capillary tube (12) to the pressure prevailing at the unit or to a separate compressed air connection (see section 5.3).
7. Connect other mounting parts, if applicable.

¹⁾ Formerly Type 2114

5.2 Mounting the safety pressure limiter onto the valve

The Type 2401-1 Safety Pressure Limiter (SPL) and valve are delivered separately and must be fastened together before installing the valve in the pipeline. The tension of the spring mechanism is relieved in the delivered state and the pin (6) of the spring mechanism sticks out of the device. The safety pressure limiter is locked.

i Note

Compressed air is required to mount the safety pressure limiter.

1. Screw the assembly tool (M, 0230-3752) onto the connecting element (8) (see Fig. 2).

2. Clamp the safety pressure limiter firmly onto the assembly tool (M).
3. Connect the capillary tube (12) to the pressure prevailing at the unit or to a separate compressed air connection (see section 5.3).
4. Apply a pressure of at least 1 bar and approx. 0.5 bar below the adjusted limit to the connection of the capillary tube.
5. Place the lever for unlocking at the pins at the side on the connecting element (8) (see Fig. 3). Pull the lever upward until the spring mechanism is tensioned. The side pins are pushed downward and the spring assembly compressed. The safety pressure limiter is unlocked.
6. Remove the assembly tool (M).
7. Place on coupling nut (7) and tighten.
8. Connect other mounting parts, if applicable.

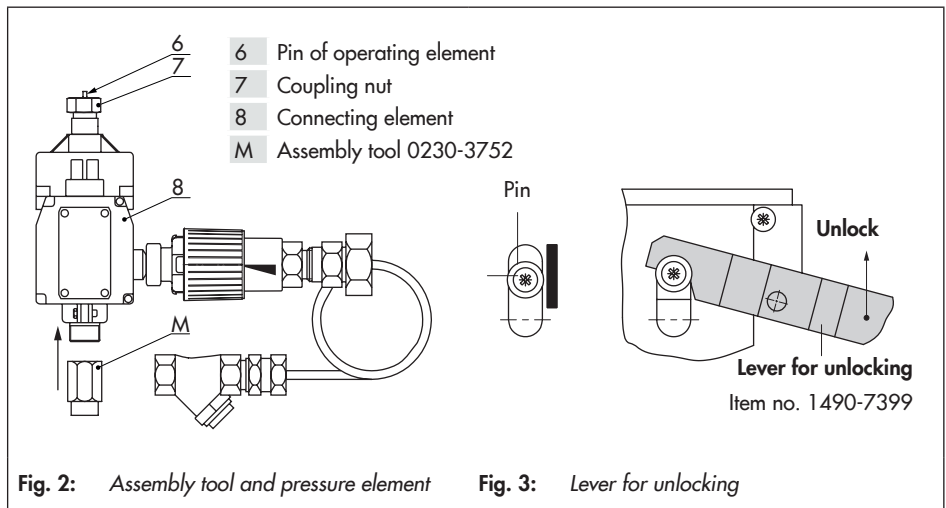

5.3 Connecting the capillary tube

Proceed as follows:

- Additional steps to be performed beforehand (liquids and vapors)

The capillary tube must not contain any compressible air when used with liquids or vapors as the process medium.

1. Use a plastic funnel or jug to pour water into the open screw fitting of the capillary tube until it starts to overflow.
- Steps to be performed afterwards (liquids, gases and vapors)
2. Insert seals into the screw fitting. Observe correct sequence according to Fig. 4.
3. A G $\frac{1}{2}$ connecting sleeve must be fitted for tapping the pressure in the secondary circuit (see Fig. 1). The strainer of the capillary tube is bolted on tightly at this

point. The capillary tube must be run in such a way that it cannot be damaged.

4. Screw the strainer and pressure element tightly together.

5.4 Installing the valve into the pipeline

5.4.1 Mounting orientation

- Choose a place of installation that allows you to freely access the device even after the entire plant has been completed.
- Install the valve in horizontal pipelines.
- Install the device with the connecting element hanging downward.
- During installation, observe the flow direction through the valve. The arrow on the valve indicates the direction of flow.
- Observe the permissible ambient temperatures (see section 3.2).

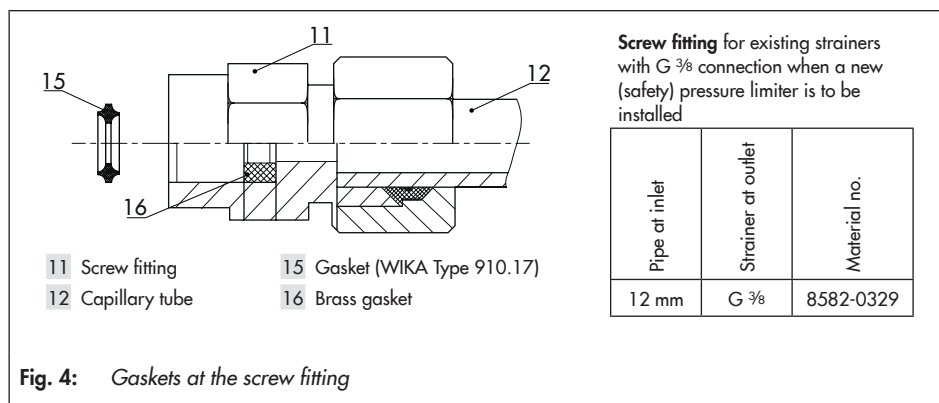

5.4.2 Additional fittings

Additional electric unit (electric signal transmitter)

An additional electric signal transmitter for remote transmission of the plant state can be attached to the operating element with spring mechanism.

The signal transmitter contains a microswitch (max. load 10 A, 125 V, 250 V) which generates a signal when the limit value of the pressure element is exceeded for remote transmission of the plant state.

5.4.3 Installing the valve

1. Close the shut-off valve in the pipeline while the valve is being installed.
2. Remove the protective caps from the valve ports before installing the valve.
3. Lift the valve using suitable lifting equip-

ment to the site of installation (see section 4.2.2). Observe the flow direction through the valve. The arrow on the valve indicates the direction of flow.

4. Bolt the pipe to the valve free of stress.
5. Depending on the field of application, allow the valve to cool down or warm up to reach ambient temperature before start up.
6. Slowly open the shut-off valve in the pipeline after the valve has been installed.

NOTICE

Risk of valve damage due to a sudden pressure increase and resulting high flow velocities.

Slowly open the shut-off valve in the pipeline during start-up.

7. Check the valve to ensure it functions properly.

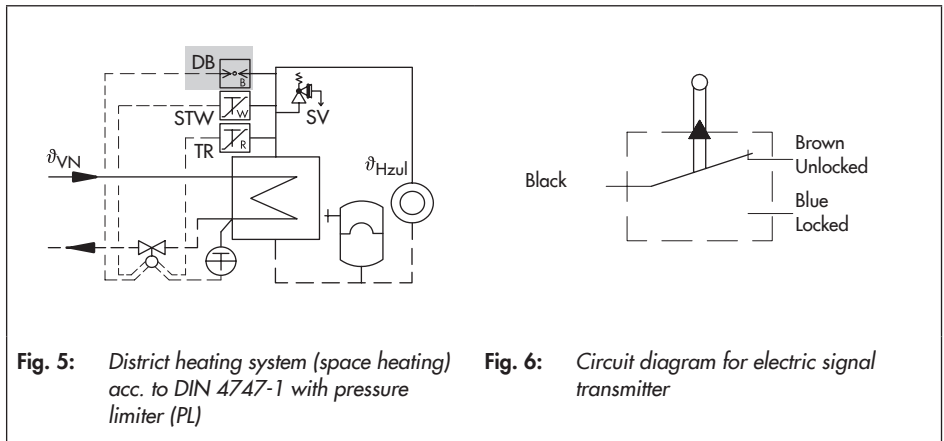

Fig. 5: District heating system (space heating) acc. to DIN 4747-1 with pressure limiter (PL)

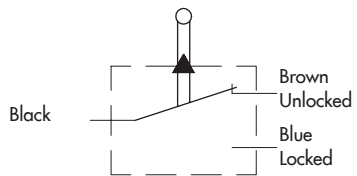

Fig. 6: Circuit diagram for electric signal transmitter

6 Operation

⚠ WARNING

Risk of personal injury due to hazards at the device.

- Before starting any work on the device, depressurize all plant sections affected as well as the valve and pressure element.
- Drain the process medium from all the plant sections affected as well as the valve.
- When used at high temperatures, allow the plant section to cool down to ambient temperature.
- Wear personal protective equipment.

6.1 Adjusting the limit

Adjust the required limit by turning the black plastic ring according to the scale 0 to 4 (limit range between 1 and 10 bar). See Fig. 7.

- ➔ Turn counterclockwise \curvearrowright to increase the limit value (+).
- ➔ Turn clockwise \curvearrowleft to reduce the limit value (-).

One turn corresponds to a change in the limit value by approximately 0.4 bar.

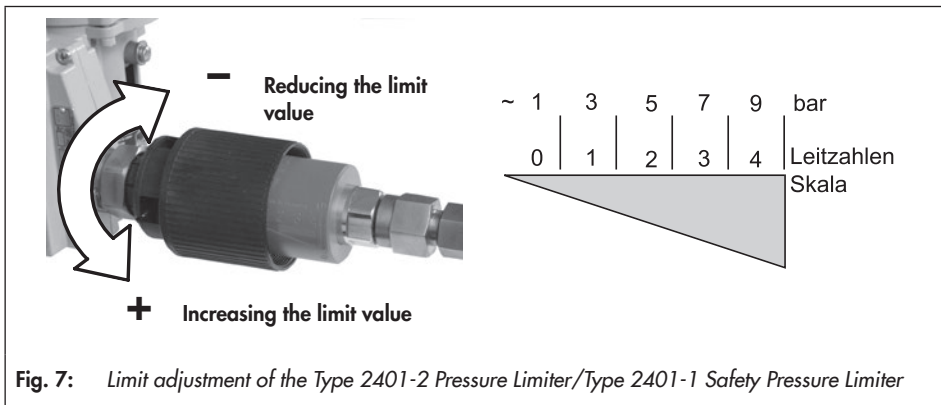

Fig. 7: Limit adjustment of the Type 2401-2 Pressure Limiter/Type 2401-1 Safety Pressure Limiter

6.2 Unlocking after a fault

6.2.1 Unlocking the pressure limiter

To unlock the pressure limiter, the following conditions must be met:

- The pressure must fall approx. 0.5 bar below the limit.
- The pressure is >1 bar.

To unlock the pressure limiter, proceed as follows:

1. Rectify the fault.
2. Place the lever for unlocking at the pins at the side on the connecting element (8) (see Fig. 8). Pull the lever upward until the spring mechanism is tensioned. The side pins are pushed downward and the spring assembly compressed. The pressure limiter is unlocked.

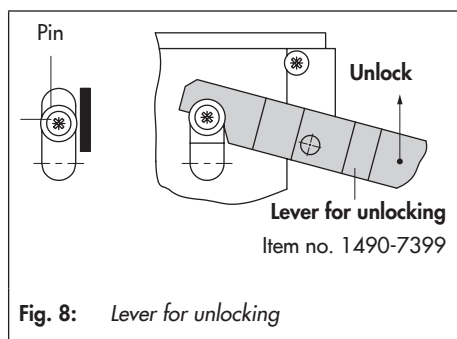

Fig. 8: Lever for unlocking

6.2.2 Unlocking the safety pressure limiter

The safety pressure limiter is tested as a special construction according to section 3.3 of VdTÜV Code 100 (pressure). The trigger element with spring return mechanism can also be fitted with an additional component to add the additional function of a safety temperature limiter according to DIN EN 14597 in addition to a safety pressure limiter.

i Note

In all cases, the safety pressure limiter or safety temperature limiter must act on a SAMSON valve.

As soon as the adjusted pressure limit is reached or, for example when the capillary tube breaks or when leakage occurs in the pressure measuring system, the valve is closed and locked by the spring mechanism.

1. Rectify the fault.
2. Apply a pressure of at least 1 bar and approx. 0.5 bar below the adjusted limit to the connection of the capillary tube.
3. Place the lever for unlocking at the pins at the side on the connecting element (8) (see Fig. 8). Pull the lever upward until the spring mechanism is tensioned. The side pins are pushed downward and the spring assembly compressed. The safety pressure limiter is unlocked.

7 Servicing

DANGER

Risk of bursting in pressure equipment.

The valve and pressure element are pressure equipment. Improper opening can lead to bursting of the parts. In the installed state, the spring in the operating element is pre-loaded. Incorrect dismantling will release a high amount of energy, which may lead to serious injury.

- Do not dismantle the device.
 - Contact SAMSON's After-sales Service for support concerning maintenance or repair work or when malfunctions or defects arise.
-

Note

The product warranty becomes void if service or repair work not described in these instructions is performed without prior agreement by SAMSON's After-sales Service.

7.1 Preparation for return shipment

Proceed as follows to return devices to SAMSON:

1. Put the control valve out of operation (see section 8).
2. Decontaminate the valve. Remove any residual process medium.
3. Fill in the Declaration on Contamination. The declaration form can be downloaded from our website at
▶ www.samsongroup.com > SERVICE & SUPPORT > After-sales Service.
4. Continue as described on our website at
▶ www.samsongroup.com > Service & Support > After-sales Service > Returning goods.

7.2 Ordering spare parts and operating supplies

Contact your nearest SAMSON subsidiary or SAMSON's After-sales Service for information on spare parts, lubricants and tools.

8 Decommissioning and removal

⚠ DANGER

Risk of bursting in pressure equipment.

The valve and pressure element are pressure equipment. Improper opening can lead to bursting of the parts. In the installed state, the spring in the operating element is pre-loaded. Incorrect dismantling will release a high amount of energy, which may lead to serious injury.

- Do not dismantle the device.
- Contact SAMSON's After-sales Service for support concerning maintenance or repair work or when malfunctions or defects arise.

⚠ WARNING

Risk of burn injuries due to hot or cold components and pipeline.

Valve components and the pipeline may become very hot or cold. Risk of burn injuries.

- Allow components and pipelines to cool down or warm up to the ambient temperature.
- Wear protective clothing and safety gloves.

⚠ WARNING

Risk of personal injury due to residual process medium in the valve.

While working on the valve, residual medium can flow out of the valve and, depending on its properties, cause personal injury, e.g. (chemical) burns.

Wear protective clothing, safety gloves and eye protection.

8.1 Decommissioning

1. Close the shut-off valve on the upstream side.
2. Close the shut-off valve on the downstream side.
3. Completely drain the pipelines and valve.
4. Depressurize the plant.
5. If necessary, allow the pipeline and device to cool down or warm up to the ambient temperature.

8.2 Removing the valve from the pipeline

1. Put the device out of operation. See section 8.1.
2. Unbolt the flanged joint.
3. Remove the valve from the pipeline.

8.3 Disposal



We are registered with the German national register for waste electric equipment (stiftung ear) as a producer of electrical and electronic equipment, WEEE reg. no.: DE 62194439

- Observe local, national and international refuse regulations.
- Do not dispose of components, lubricants and hazardous substances together with your other household waste.

i Note

We can provide you with a recycling passport according to PAS 1049 on request. Simply e-mail us at aftersalesservice@samsongroup.com giving details of your company address.

💡 Tip

On request, we can appoint a service provider to dismantle and recycle the product.

9 After-sales service

After-sales Service

You can reach our after-sales service at aftersalesservice@samsongroup.com.

Addresses of SAMSON AG and its subsidiaries

The addresses of SAMSON, its subsidiaries, representatives and service facilities worldwide can be found on our website ([▶ www.samsongroup.com](http://www.samsongroup.com)) or in all SAMSON product catalogs.

Required specifications

Please submit the following details:

- Order number and position number in the order
- Material number of pressure element and valve
- Type, model number, valve size and valve version
- Upstream and downstream pressure
- Medium temperature and process medium
- Min. and max. flow rate in m³/h
- Is a strainer installed?
- Installation drawing showing the exact location of the valve and all the additionally installed components (shut-off valves, pressure gauge etc.)

10 Certificates

The EU declarations of conformity are included on the next pages.

EU DECLARATION OF CONFORMITY
TRANSLATION



Module D, No. / N° CE-0062-PED-D-SAM 001-20-DEU

For the following products, SAMSON hereby declares under its sole responsibility:

Safety Pressure Limiter SPL 2401-1

combined with valves

2111, 2114, 2118, 2119, 2421, 2422, 2423, 2423E (2710, 2803, 2811, 2814, 2823)

the conformity with the following requirement.

Directive of the European Parliament and of the Council on the harmonization of the laws of the Member States relating of the making available on the market of pressure equipment. 2014/68/EU of 15 May 2014

EC Type Examination Certificate Module B Certificate no. 01 202 931-B-12-0031

Conformity assessment procedure applied Module D Certificate no. CE-0062-PED-D-SAM-001-20-DEU

The design is based on the procedures specified in the following standards:
DIN EN 12516-2, DIN EN 12516-3 or ASME B16.1, ASME B16.24, ASME B16.34, ASME B16.42

The manufacturer's quality management system is monitored by the following notified body:

Bureau Veritas Services SAS, 8 Cours du Triangle, 92800 PUTEAUX – LA DEFENSE, France
Manufacturer: SAMSON AG, Weismüllerstraße 3, 60314 Frankfurt am Main, Germany

Frankfurt am Main, 11. May 2020

Thorsten Muth
Senior Director
Sales and After sales

Peter Scheermesser
Head of Central Department
Product maintenance, contract development and ETO
for valves and actuators

Revision 04

Classification: Public · SAMSON AKTIENGESELLSCHAFT · Weismuellerstrasse 3 · 60314 Frankfurt am Main, Germany Seite 1 von 1

EU DECLARATION OF CONFORMITY
TRANSLATION



Module D, No. / N° CE-0062-PED-D-SAM 001-20-DEU

For the following products, SAMSON hereby declares under its sole responsibility:

Pressure Limiter PL 2401-2

the conformity with the following requirement.

Directive of the European Parliament and of the Council on the harmonization of the laws of the Member States relating to the making available on the market of pressure equipment. 2014/68/EU of 15 May 2014

EC Type Examination Certificate Module B Certificate no. 01 202 931-B-12-0032

Conformity assessment procedure applied Module D Certificate no. CE-0062-PED-D-SAM-001-20-DEU

The design is based on the procedures specified in the following standards:
DIN EN 12516-2, DIN EN 12516-3 or ASME B16.1, ASME B16.24, ASME B16.34, ASME B16.42

The manufacturer's quality management system is monitored by the following notified body:

Bureau Veritas Services SAS, 8 Cours du Triangle, 92800 PUTEAUX – LA DEFENSE, France
Manufacturer: SAMSON AG, Weismüllerstraße 3, 60314 Frankfurt am Main, Germany

Frankfurt am Main, 11. May 2020

Torsten Muth
Senior Director
Sales and After-sales

Peter Scheermesser
Head of Central Department
Product maintenance, contract development and ETO
for valves and actuators

Revision 04

Classification: Public · SAMSON AKTIENGESELLSCHAFT · Weismüllerstraße 3 · 60314 Frankfurt am Main, Germany Seite 1 von 1

EB 2519 EN



SAMSON AKTIENGESELLSCHAFT
Weismüllerstraße 3 · 60314 Frankfurt am Main, Germany
Phone: +49 69 4009-0 · Fax: +49 69 4009-1507
samson@samsongroup.com · www.samsongroup.com