

MOUNTING AND OPERATING INSTRUCTIONS



EB 1010 EN

Translation of original instructions



Type 1 N and Type 1 NI Strainers

Note on these mounting and operating instructions

These mounting and operating instructions assist you in mounting and operating the device safely. The instructions are binding for handling SAMSON devices.

- For the safe and proper use of these instructions, read them carefully and keep them for later reference.
- If you have any questions about these instructions, contact SAMSON's After-sales Service (aftersalesservice@samsongroup.com).



The mounting and operating instructions for the devices are included in the scope of delivery. The latest documentation is available on our website at www.samsongroup.com > **Service & Support** > **Downloads** > **Documentation**.

Definition of signal words

DANGER

Hazardous situations which, if not avoided, will result in death or serious injury

WARNING

Hazardous situations which, if not avoided, could result in death or serious injury

NOTICE

Property damage message or malfunction

Note

Additional information

Tip

Recommended action

| | | |
|----------|---|-----------|
| 1 | Safety instructions and measures | 4 |
| 1.1 | Notes on possible severe personal injury | 6 |
| 1.2 | Notes on possible personal injury | 7 |
| 1.3 | Notes on possible property damage | 8 |
| 2 | Markings on the device | 9 |
| 2.1 | Marking on the strainer body | 9 |
| 2.2 | Material numbers | 9 |
| 3 | Design and principle of operation | 10 |
| 3.1 | Technical data | 10 |
| 4 | Measures for preparation | 13 |
| 4.1 | Unpacking | 13 |
| 4.2 | Transporting and lifting | 13 |
| 4.3 | Storage | 13 |
| 4.4 | Preparation for installation | 14 |
| 5 | Mounting and start-up | 14 |
| 5.1 | Mounting positions | 14 |
| 5.2 | Additional fittings | 15 |
| 5.3 | Installing the strainer | 15 |
| 5.4 | Start-up | 16 |
| 5.4.1 | Gases and liquids | 16 |
| 5.4.2 | Steam | 16 |
| 6 | Servicing | 17 |
| 6.1 | Cleaning or exchanging the filter | 18 |
| 6.2 | Preparation for return shipment | 19 |
| 6.3 | Ordering spare parts and operating supplies | 19 |
| 7 | Malfunctions | 19 |
| 8 | Decommissioning and removal | 21 |
| 8.1 | Decommissioning | 21 |
| 8.2 | Disposal | 21 |
| 9 | Annex | 22 |
| 9.1 | After-sales service | 22 |
| 9.2 | Spare parts, tightening torques and lubricant | 22 |
| 9.3 | Certificate | 22 |

1 Safety instructions and measures

Intended use

The SAMSON Type 1 N and Type 1 NI Strainers are used to hold back large particles contained in liquids, gases and vapors. The strainers are designed to operate under exactly defined conditions (e.g. operating pressure, process medium, temperature). Therefore, operators must ensure that the strainers are only used in operating conditions that meet the specifications used for sizing the strainers at the ordering stage. In case operators intend to use the strainers in other applications or conditions than specified, contact SAMSON.

SAMSON does not assume any liability for damage resulting from the failure to use the device for its intended purpose or for damage caused by external forces or any other external factors.

➔ Refer to the technical data and nameplate for limits and fields of application as well as possible uses.

Reasonably foreseeable misuse

The strainers are not suitable for the following applications:

- Use outside the limits defined during sizing and by the technical data

Furthermore, the following activities do not comply with the intended use:

- Use of non-original spare parts
- Performing service and repair work not described in these instructions

Qualifications of operating personnel

The strainer must be mounted, started up, serviced and repaired by fully trained and qualified personnel only; the accepted industry codes and practices are to be observed.

According to these mounting and operating instructions, trained personnel refers to individuals who are able to judge the work they are assigned to and recognize possible hazards due to their specialized training, their knowledge and experience as well as their knowledge of the applicable standards.

Revisions and other modifications

Revisions, conversions or other modifications of the product are not authorized by SAMSON. They are performed at the user's own risk and may lead to safety hazards, for example. Furthermore, the product may no longer meet the requirements for its intended use.

Personal protective equipment

We recommend checking the hazards posed by the process medium being used (e.g. ► GESTIS (CLP) hazardous substances database).

- ➔ Provide protective equipment (e.g. safety gloves, eye protection) appropriate for the process medium used.
- ➔ Wear hearing protection when working near the strainer.
- ➔ Check with the plant operator for details on further protective equipment.

Warning against residual hazards

To avoid personal injury or property damage, operators and operating personnel must prevent hazards that could be caused in the strainer by the process medium and operating pressure by taking appropriate precautions. They must observe all hazard statements, warning and caution notes in these mounting and operating instructions, especially for installation, start-up and service work.

We also recommend checking the hazards posed by the process medium being used (e.g. ► GESTIS (CLP) hazardous substances database).

- ➔ Observe safety measures for handling the device as well as fire prevention and explosion protection measures.

Responsibilities of the operator

The operator is responsible for proper operation and compliance with the safety regulations. Operators are obliged to provide these mounting and operating instructions as well as the referenced documents to the operating personnel and to instruct them in proper operation. Furthermore, the operator must ensure that operating personnel or third persons are not exposed to any danger.

Responsibilities of operating personnel

Operating personnel must read and understand these mounting and operating instructions as well as the referenced documents and observe the specified hazard statements, warnings and caution notes. Furthermore, the operating personnel must be familiar with the applicable health, safety and accident prevention regulations and comply with them.

Referenced standards and regulations

The strainers comply with the requirements of the European Pressure Equipment Directive 2014/68/EU. Strainers with a CE marking have an EU declaration of conformity, which includes information about the applied conformity assessment procedure. This EU declaration of conformity is included in the annex of these instructions (see section 9.3).

1.1 Notes on possible severe personal injury

DANGER

Risk of bursting in pressure equipment.

Strainers and pipelines are pressure equipment. Improper opening can lead to strainer components bursting.

- If necessary, a suitable overpressure protection must be installed on site in the plant section.
- Before starting any work on the strainer, depressurize all plant sections concerned.
- Drain the process medium from all the plant sections affected as well as from the strainer.
- Wear personal protective equipment.

1.2 Notes on possible personal injury

WARNING

Risk of personal injury due to residual process medium in the strainer.

While working on the strainer, residual process medium can escape and, depending on its properties, may lead to personal injury, e.g. (chemical) burns.

- If possible, drain the process medium from all the plant sections affected and the strainer.
- Wear protective clothing, safety gloves and eye protection.

Risk of burn injuries due to hot or cold components and pipelines.

Depending on the process medium, strainer components and pipelines may get very hot or cold and cause burn injuries.

- Allow components and pipelines to cool down or heat up.
- Wear protective clothing and safety gloves.

1.3 Notes on possible property damage

! NOTICE

Risk of the strainer becoming blocked due to contamination (e.g. solid particles) in the pipeline.

The plant operator is responsible for cleaning the pipelines in the plant.

- Do not use the strainer to permanently filter the process medium.
- Observe the maximum permissible pressure for strainer and plant.
- Observe the maximum permissible differential pressure for strainer and plant.

Risk of strainer damage due to unsuitable medium properties.

The strainer is designed for a process medium with defined properties.

- Only use the process medium specified for sizing.

Risk of strainer damage due to the use of unsuitable lubricants.

The lubricants to be used depend on the strainer material. Unsuitable lubricants may corrode and damage the surface.

- Only use lubricants approved by SAMSON (see section 9.2).

Risk of leakage and strainer damage due to excessively high or low tightening torques.

Observe the specified torques on tightening strainer components. Excessively tightened torques lead to parts wearing out quicker. Parts that are too loose may cause leakage.

- Observe the specified tightening torques (see section 9.2).

2 Markings on the device

2.1 Marking on the strainer body

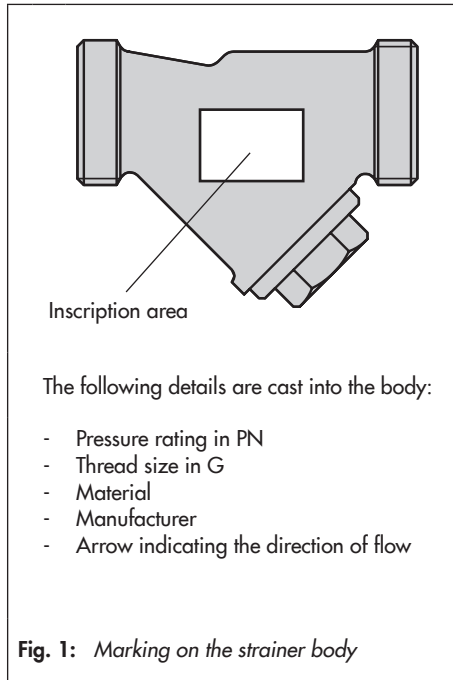

2.2 Material numbers

The material number is cast into the body. See Fig. 1 for further details on the cast body.

You can also contact SAMSON specifying the configuration ID to find out the material used.

3 Design and principle of operation

→ See Fig. 2

The Type 1 N and Type 1 NI Strainers consist of a Y-style body (1) with threaded connections, filter (2), seal (3) and a screw cap (4) for the filter.

The strainer installed upstream of the valve is used to hold back any dirt or other foreign particles carried along by the medium.

The process medium flows through the body in the direction indicated by the arrow.

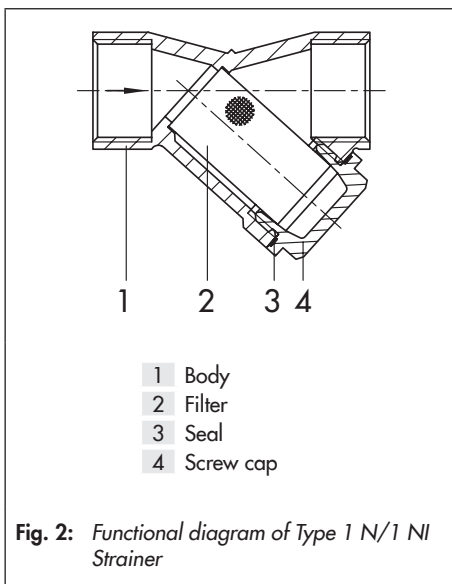

3.1 Technical data

The strainer body contains information on the strainer version (see section 2.1).

Process medium and scope of application

The **Type 1 N and Type 1 NI** Strainers are suitable for use with **liquids, vapors and gases**.

Temperature range

The Type 1 N and Type 1 NI are designed for a temperature range from -10 to $+200$ °C (14 to 390 °F).

Noise emissions

SAMSON is unable to make general statements about noise emissions. The noise emissions depend on the strainer version, plant facilities and process medium.

⚠ WARNING

Risk of hearing loss or deafness due to loud noise.

Wear hearing protection when working near the strainer.

Dimensions and weights

Table 4 provides a summary of the dimensions and weights of Type 1 N and Type 1 NI Strainers. The lengths and heights in the dimensional drawing are shown in Fig. 3.

Table 1: *Technical data*

| Type 1 N/Type 1 NI | |
|------------------------------|--------------------------|
| Connection | G ½ to G 2 female thread |
| Pressure rating | PN 25 |
| Max. permissible temperature | 200 °C |
| Conformity | CE |

Table 2: *Materials · Material numbers according to DIN EN*

| Type 1 N/Type 1 NI | |
|--------------------|------------------|
| Body | Brass CB752S |
| Filter | 1.4401 |
| Screw cap | Brass CB752S |
| Seal | Novatec® Premium |

Table 3: *K_{VS} coefficients · Flow resistance coefficient*

| Thread size in G | | ½ | ¾ | 1 | 1¼ | 1½ | 2 |
|-----------------------------|------|--------------------------------------|------|------|------|------|------|
| Type 1 N | | | | | | | |
| K _{VS} coefficient | m³/h | 5.6 | 10.0 | 15.6 | 25.5 | 40.0 | 63.0 |
| Mesh size | mm | 0.5 | | | 0.75 | | |
| Mesh count per cm² | | 150 | | | 64 | | |
| Free filter area | | Approx. 3 times pipe cross-section | | | | | |
| Flow resistance coefficient | ζ | 2.5 | | | | | |
| Type 1 NI | | | | | | | |
| K _{VS} coefficient | m³/h | 5.1 | 9.1 | 14.3 | 23.0 | 36.3 | 57.0 |
| Mesh size | mm | 0.25 | | | | | |
| Mesh count per cm² | | 625 | | | | | |
| Free filter area | | Approx. 2.5 times pipe cross-section | | | | | |
| Flow resistance coefficient | z | 3 | | | | | |

Design and principle of operation

Table 4: Dimensions · Weights

| Thread size in G | | ½ | ¾ | 1 | 1¼ | 1½ | 2 |
|---------------------------------|----|------|-----|------|------|------|------|
| AF1 | | 26 | 32 | 41 | 50 | 54.5 | 69.5 |
| AF2 | | 19 | 22 | 30 | 32 | 41 | 50 |
| Length L | mm | 65 | 75 | 90 | 110 | 120 | 150 |
| H1 | mm | 40 | 45 | 56 | 73 | 84 | 108 |
| H2 (strainer insert pulled out) | mm | 63.5 | 77 | 96.5 | 115 | 131 | 160 |
| Weight, approx. | kg | 0.2 | 0.3 | 0.47 | 0.77 | 1.35 | 1.9 |

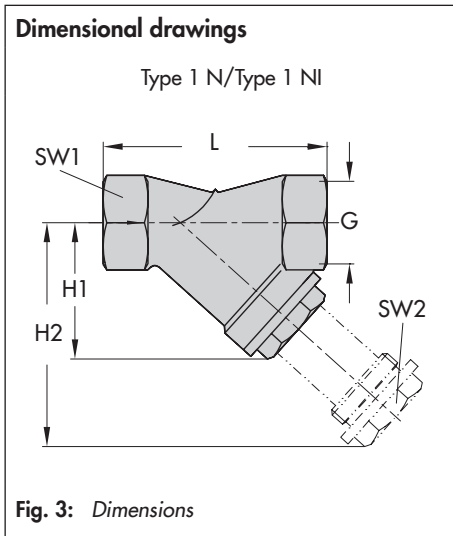

Pressure-temperature diagram

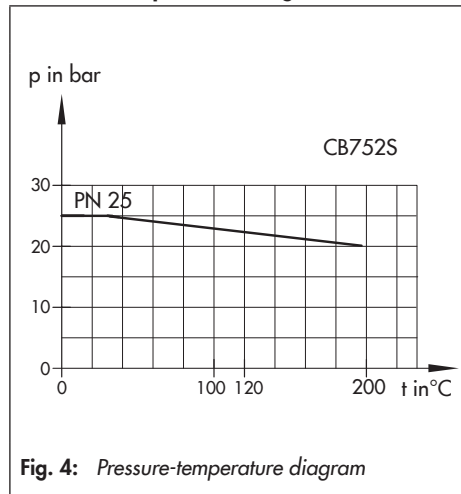

4 Measures for preparation

After receiving the shipment, proceed as follows:

1. Check the scope of delivery. Compare the shipment received with the delivery note.
2. Check the shipment for transportation damage. Report any damage to SAMSON and the forwarding agent (refer to delivery note).

4.1 Unpacking

i Note

Do not remove the packaging until immediately before installing the valve into the pipeline.

Before installing the strainer, proceed as follows:

1. Remove the packaging from the strainer.
2. Dispose of the packaging in accordance with the valid regulations.

4.2 Transporting and lifting

Due to the low service weight, lifting equipment is not required to lift and transport the strainer (e.g. to install it into the pipeline).

Transport instructions

- Protect the device against external influences (e.g. impact).
- Protect the device against moisture and dirt.

- Observe the permissible ambient temperatures (see section 3.1).

4.3 Storage

! NOTICE

Risk of strainer damage due to improper storage.

- *Observe the storage instructions.*
- *Avoid long storage times.*
- *Contact SAMSON in case of different storage conditions or long storage periods.*

i Note

We recommend regularly checking the device and the prevailing storage conditions during long storage periods.

Storage instructions

- Protect the device against external influences (e.g. impact).
- Protect the device against moisture and dirt. Store it at a relative humidity of less than 75 %. In damp spaces, prevent condensation. If necessary, use a drying agent or heating.
- Make sure that the ambient air is free of acids or other corrosive media.
- Observe the permissible ambient temperatures (see section 3.1).
- Do not place any objects on the device.



Tip

SAMSON's After-sales Service can provide more detailed storage instructions on request.

4.4 Preparation for installation

Proceed as follows:

→ Flush the pipelines.



Note

The plant operator is responsible for cleaning the pipelines in the plant.

- Check the strainer to make sure that it is clean.
- Check the strainer for damage.
- Check to make sure that the type designation, thread size, material, pressure rating and temperature range of the strainer match the plant conditions (size and pressure rating of the pipeline, medium temperature etc.).
- Check any mounted pressure gauges to make sure they function.

5 Mounting and start-up

! NOTICE

Risk of overheating due to excessive ambient temperatures or insufficient heat dissipation when components are insulated.

- Do not include the strainer in the insulation of the pipeline.

! NOTICE

Risk of impaired functioning of the strainer and leakage at the joint due to installation under tension.

- Bolt the strainer to the pipeline free of stress.
- If necessary, support the pipelines near to the connections.
- Do not attach supports directly to the strainer.

5.1 Mounting positions

Horizontal pipelines

- **Gases and liquids**
Screw cap and filter face downwards.
- **Steam**
Screw cap and filter face sideward.

Vertical pipelines

- **Gases, vapors and liquids**
In strainers where the medium flows upward, the screw cap and filter face upward.

Installation conditions

- Make sure that the strainer remains freely accessible after the plant has been completed.
- Make sure the direction of flow matches the direction indicated by the arrow on the body.
- Allow sufficient space to remove the filter.
- Install the strainer free of stress.

! NOTICE

Possible malfunction and damage due to adverse weather conditions (temperature, humidity).

- Do not install the device outdoors or in rooms prone to frost.*
 - Protect the strainer against frost if it is used in combination with freezing media.*
 - Either heat the strainer or remove it from the plant and completely drain the residual medium after a plant shutdown.*
-

5.2 Additional fittings

Shut-off valves

Install a hand-operated shut-off valve both upstream and downstream of the strainer (see Fig. 5). This allows the plant to be shut down for cleaning and maintenance, and when the plant is not used for longer periods of time.

Pressure gauges

Install a pressure gauge both upstream and downstream of the strainer to monitor the pressures prevailing in the plant (see Fig. 5).

5.3 Installing the strainer

1. Close the shut-off valve in the pipeline while the valve is being installed.
2. Observe the flow direction. The arrow on the strainer indicates the direction of flow.
3. Bolt the pipeline to the strainer free of stress.
4. Depending on the field of application, allow the strainer to cool down or heat up to reach ambient temperature before start up.

5.4 Start-up

⚠ DANGER

Risk of personal injury due to process medium escaping under pressure.

– First start up the strainer after mounting all parts.

⚠ NOTICE

Risk of the body bursting due to excessive pressure during pressure testing.

– The pressure must not exceed the maximum permissible pressure by 1.5 times the pressure rating.

⚠ NOTICE

Risk of the strainer being destroyed by steam hammering.

*– Drain off any condensate in the pipeline.
– Vent the plant.*

⚠ NOTICE

Risk of strainer damage due to a sudden pressure increase and resulting high flow velocities.

Slowly open the shut-off valve in the pipeline during start-up.

Once installed in the pipeline, the strainer can be put into operation.

5.4.1 Gases and liquids

- Open the shut-off valves slowly preferably starting from the upstream pressure side.
- Avoid pressure surges.

5.4.2 Steam

- Completely drain and dry steam lines to prevent water hammering.
- Slowly allow the steam to enter the plant to ensure that the pipes and valves warm up evenly and to avoid excessive flow velocities.
- Before the full capacity is reached, drain off the start-up condensate.
- Make sure that the air contained in the plant escapes as quickly as possible.
- Open the shut-off valves slowly preferably starting from the upstream pressure side.
- Avoid pressure surges.

6 Servicing

The strainer does not require any maintenance. Nevertheless, it is subject to natural wear, particularly at the filter. Depending on the operating conditions, check the strainer at regular intervals to avoid possible malfunctions.

⚠ DANGER

Risk of bursting in pressure equipment. Strainers and pipelines are pressure equipment. Improper opening can lead to bursting of the strainer.

- Before starting any work on the strainer, depressurize all plant sections concerned as well as the strainer.
- Drain the process medium from all the plant sections affected as well as from the strainer.
- Wear personal protective equipment.

⚠ WARNING

Risk of personal injury due to residual process medium in the strainer. While working on the strainer, residual process medium can escape and, depending on its properties, may lead to personal injury, e.g. (chemical) burns. Wear protective clothing, safety gloves and eye protection.

⚠ WARNING

Risk of burn injuries due to hot or cold components and pipeline. Strainer components and the pipeline may become very hot or cold. Risk of burn injuries.

- Allow components and pipelines to cool down or heat up.
- Wear protective clothing and safety gloves.

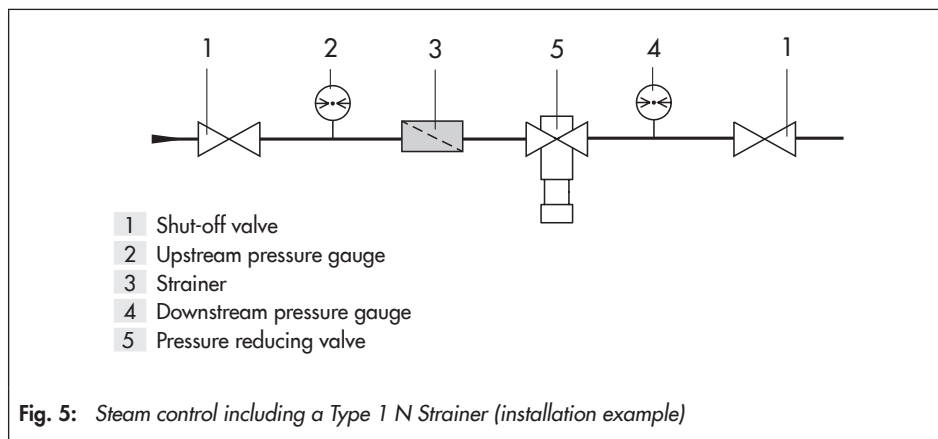

Fig. 5: Steam control including a Type 1 N Strainer (installation example)

NOTICE

Risk of strainer damage due to incorrect service or repair.

Service and repair work must be performed by trained staff only.

NOTICE

Risk of strainer damage due to excessively high or low tightening torques.

Observe the specified torques on tightening strainer components. Excessively tightened torques lead to parts wearing out quicker.

Parts that are too loose may cause leakage.

Observe the specified tightening torques (see section 9.2).

NOTICE

Risk of strainer damage due to the use of unsuitable lubricants.

Only use lubricants approved by SAMSON (see section 9.2).

Tip

SAMSON's After-sales Service can support you in drawing up an inspection and test plan for your plant.

Note

The strainer was checked by SAMSON before it left the factory.

– Certain test results certified by SAMSON lose their validity when the strainer is opened. Such testing includes leak tests.

– The product warranty becomes void if service or repair work not described in these instructions is performed without prior agreement by SAMSON's after-sales service.

– Only use original spare parts by SAMSON, which comply with the original specifications.

6.1 Cleaning or exchanging the filter

→ See Fig. 2

NOTICE

Risk of strainer damage due to excessively high or low tightening torques.

Observe the specified torques on tightening strainer components. Excessively tightened torques lead to parts wearing out quicker.

Parts that are too loose may cause leakage.

Observe the specified tightening torques (see section 9.2).

Removal

1. Put the plant out of operation (see section 8.1).
2. Unscrew the screw cap (4). See section Table 4 for size of the open-end wrench.
3. Remove filter (2) and seal (3).
4. Thoroughly clean the filter.
Replace a damaged filter.

Installation

1. Renew the seal (3) (see section 9.2) and insert the new seal in the screw plug (4).
2. Insert the filter (2) into the screw cap (4).
3. Screw on the screw cap (4). Observe the tightening torques specified in section 9.2.
4. Put the plant into operation (see section 5.4).

6.2 Preparation for return shipment

Defective strainers can be returned to SAMSON for repair. Proceed as follows to return devices to SAMSON:

1. Put the plant out of operation (see section 8.1).
2. Decontaminate the strainer. Remove any residual process medium.
3. Fill in the Declaration on Contamination. The declaration form can be downloaded from our website at
▶ www.samsongroup.com > SERVICE & SUPPORT > After-sales Service.

4. Continue as described on our website at
▶ www.samsongroup.com > Service & Support > After-sales Service > Returning goods.

6.3 Ordering spare parts and operating supplies

Contact your nearest SAMSON subsidiary or SAMSON's After-sales Service for information on spare parts, lubricants and tools.

Spare parts

See section 9.2 for details on spare parts.

Lubricant

See section 9.2 for details on suitable lubricants.

7 Malfunctions

The malfunctions listed in Table 5 are caused by mechanical faults and incorrect strainer sizing. In the simplest case, the functioning can be restored following the recommended action. Special tools may be required for repair work.

For troubleshooting, the conditions, such as installation, process medium, temperature and pressure conditions, must be taken into account.

SAMSON's After-sales Service can help during troubleshooting. Further information is available in section 9.1.

Malfunctions



Tip

SAMSON's After-sales Service can support you in drawing up an inspection and test plan for your plant.



Note

Contact SAMSON's After-sales Service for malfunctions not listed in the table.

Table 5: Troubleshooting

| Malfunction | Possible reasons | Recommended action |
|---|---|---|
| Pressure drops below the adjusted set point of the pressure regulator installed downstream. | Strainer installed against the flow. | Install the strainer so that the direction of flow matches the direction indicated by the arrow on the body. → Check the filter for deformation. Replace the filter, if necessary. |
| | Foreign particles and dirt blocking the filter. | → Remove foreign particles and dirt. → Replace a damaged filter. |
| | Strainer or K_{vs}/C_v coefficient too small. | → Check the sizing. → Install the correctly sized strainer. |
| Loud noises. | High flow velocity, cavitation. | → Check the sizing. → If necessary, install a larger strainer. → Check the filter for deformation. Replace the filter, if necessary. |
| Leakage at the strainer. | The seal is defective. | → Replace damaged parts. |

8 Decommissioning and removal

⚠ DANGER

Risk of bursting in pressure equipment. Strainers and pipelines are pressure equipment. Improper opening can lead to bursting of the strainer.

- Before starting any work on the strainer, depressurize all plant sections concerned as well as the strainer.
- Drain the process medium from all the plant sections affected as well as from the strainer.
- Wear personal protective equipment.

⚠ WARNING

Risk of personal injury due to residual process medium in the strainer. While working on the strainer, residual process medium can escape and, depending on its properties, may lead to personal injury, e.g. (chemical) burns. Wear protective clothing, safety gloves and eye protection.

⚠ WARNING

Risk of burn injuries due to hot or cold components and pipeline.

Strainer components and the pipeline may become very hot or cold. Risk of burn injuries.

- Allow components and pipelines to cool down or heat up.
- Wear protective clothing and safety gloves.

8.1 Decommissioning

To decommission the strainer for service and repair work or disassembly, proceed as follows:

1. Close the shut-off valve on the upstream side.
2. Close the shut-off valve on the downstream side.
3. Depressurize the plant.
4. If necessary, allow the pipeline and strainer to cool down or heat up.
5. Completely drain the pipelines and strainer.
6. Remove the strainer from the pipeline.

8.2 Disposal

- ➔ Observe local, national and international refuse regulations.
- ➔ Do not dispose of components, lubricants and hazardous substances together with your household waste.

9 Annex

9.1 After-sales service

Contact SAMSON's After-sales Service for support concerning service or repair work or when malfunctions or defects arise.

E-mail address

You can reach our after-sales service at aftersalesservice@samsongroup.com.

Addresses of SAMSON AG and its subsidiaries

The addresses of SAMSON, its subsidiaries, representatives and service facilities worldwide can be found on our website (► www.samsongroup.com) or in all SAMSON product catalogs.

To assist diagnosis and in case of an unclear mounting situation, specify the following details (so far as possible). See section 2:

- Type and thread size
- Upstream and downstream pressure
- Temperature and process medium
- Max. flow rate
- Installation drawing showing the exact location of the strainer and all the additionally installed components (shut-off valves, pressure gauge etc.)

9.2 Spare parts, tightening torques and lubricant

| Thread size in G | | ½ | ¾ | 1 | 1¼ | 1½ | 2 |
|--|---------------|--------------------|--------------|------|--------------|--------------|--------------|
| Spare parts for Type 1 N | | Order no. | | | | | |
| Standard strainer insert | 0550 - | 0745 | 0746 | 0747 | 0748 | 0749 | 0750 |
| Spare parts for Type 1 NI | | | | | | | |
| Dual strainer insert | 0550 - | 0751 | 0752 | 0753 | 0754 | 0755 | 0756 |
| Spare parts for Type 1 N/ Type 1 NI | | | | | | | |
| Seal | 8413 - | 1569 | 1570 | 1571 | 1572 | 1573 | 1574 |
| Tightening torque for screw cap | | ~25 Nm | ~25 to 30 Nm | | ~30 to 40 Nm | ~40 to 50 Nm | ~50 to 60 Nm |
| Screw cap | 0070 - | 0408 | 0164 | 0411 | 0412 | 0167 | 0168 |
| Lubricant | | 8150 - 4008 | | | | | |

9.3 Certificate

The EU declaration of conformity is provided on the next page.

SMART IN FLOW CONTROL.



EU-KONFORMITÄTSERKLÄRUNG EU DECLARATION OF CONFORMITY

Modul H/Module H, Nr./No. / N° CE-0062-PED-H-SAM 001-16-DEU-rev-A

SAMSON erklärt in alleiniger Verantwortung für folgende Produkte:/For the following products, SAMSON hereby declares under its sole responsibility:

Schmutzfänger/Strainers

Typ/Type 1N, 1NI, 1FN, 1FNI (Erz.-Nr./Model No. 2601), 2N, 2NI (2602)

die Konformität mit nachfolgender Anforderung/the conformity with the following requirement

Richtlinie des Europäischen Parlaments und des Rates zur Harmonisierung der Rechtsvorschriften der Mitgliedstaaten über die Bereitstellung von Druckgeräten auf dem Markt. 2014/68/EU vom 15.05.2014

Directive of the European Parliament and of the Council on the harmonization of the laws of the Member States relating of the making available on the market of pressure equipment. 2014/68/EU of 15 May 2014

Angewandtes Konformitätsbewertungsverfahren für Fluide nach Art. 4(1)(c.ii) und (c.i) zweiter Gedankenstrich. Modul siehe Tabelle durch certified by Bureau Veritas S. A. (0062)

Conformity assessment procedure applied for fluids according to Article 4(1)(c.ii) and (c.i), second indent See table for module

| Typ/Type | Nenndruck Pressure rating | DN NPS | - 3/8 | 15 ½ | 20 ¾ | 25 1 | 32 1 ¼ | 40 1 ½ | 50 2 | 65 - | 80 3 | 100 4 | 125 - | 150 6 | 200 8 | 250 10 |
|-----------------------|------------------------------|--------------|--------------|---------|---------|---------|-----------|-----------|---------|---------|---------|----------|----------|----------|----------|-----------|
| 2N, 2NI | PN 10 / PN 16 | --- | ohne/without | | | | | | | | A (1) | | | H | | |
| 1N, 1NI, 1FN, 1FNI | PN 25 | ohne/without | | | | | | | A (1) | | | | | | | |

(1) Die Identifikationsnummer 0062 von Bureau Veritas S.A. gilt nicht für Modul A.
The identification number 0062 of Bureau Veritas S.A. is not valid for Modul A.

Geräte, denen laut Tabelle das Konformitätsbewertungsverfahren Modul H zugrunde liegt, beziehen sich auf die „Zulassungsbescheinigung eines Qualitätssicherungssystems“ ausgestellt durch die benannte Stelle.

Devices whose conformity has been assessed based on Module H refer to the certificate of approval for the quality management system issued by the notified body.

Dem Entwurf zu Grunde gelegt sind Verfahren aus:/The design is based on the procedures specified in the following standards:
DIN EN 12516-2, DIN EN 12516-3 bzw./or ASME B16.1, ASME B16.24, ASME B16.34, ASME B16.42

Das Qualitätssicherungssystem des Herstellers wird von folgender benannter Stelle überwacht:

The manufacturer's quality management system is monitored by the following notified body:

**Bureau Veritas S.A. Nr./No. 0062, Newtime, 52 Boulevard du Parc, Ile de la Jatte, 92200 Neuilly sur Seine, France
Hersteller/Manufacturer: SAMSON AG, Weismüllerstraße 3, 60314 Frankfurt am Main, Germany**

Frankfurt am Main, 08. Februar 2017/08 February 2017

Klaus Hörschken
Zentralabteilungsleiter/Head of Central Department
Entwicklung Ventile und Antriebe/R&D, Valves and Actuators

Dr. Michael Heß
Zentralabteilungsleiter/Head of Central Department
Product Management & Technical Sales

SAMSON AKTIENGESELLSCHAFT
Weismüllerstraße 3 60314 Frankfurt am Main

Telefon: 069 4009-0 · Telefax: 069 4009-1507
E-Mail: samson@samson.de

Revision 03

EU-Konformitätserklärung_BIart_07_Modul-A_Modul-H_DE-EN_Rev03_2017-02-08.docx



SAMSON AKTIENGESELLSCHAFT
Weismüllerstraße 3 · 60314 Frankfurt am Main, Germany
Phone: +49 69 4009-0 · Fax: +49 69 4009-1507
samson@samsongroup.com · www.samsongroup.com